

Air Force Institute of Technology

AFIT Scholar

Theses and Dissertations

Student Graduate Works

3-1998

Using Bayesian Statistics in Operational Testing

Thuan H. Tran

Follow this and additional works at: <https://scholar.afit.edu/etd>



Part of the [Operational Research Commons](#)

Recommended Citation

Tran, Thuan H., "Using Bayesian Statistics in Operational Testing" (1998). *Theses and Dissertations*. 5778.
<https://scholar.afit.edu/etd/5778>

This Thesis is brought to you for free and open access by the Student Graduate Works at AFIT Scholar. It has been accepted for inclusion in Theses and Dissertations by an authorized administrator of AFIT Scholar. For more information, please contact AFIT.ENWL.Repository@us.af.mil.

19980427 132



DISTRIBUTION STATEMENT E
Approved for public release
Distribution Unlimited

USING BAYESIAN STATISTICS
IN OPERATIONAL TESTING
THESIS
Thuan H. Tran, Captain, USAF
AFIT/GOR/ENS/98M-25

DTIC QUALITY INSPECTED 4

DEPARTMENT OF THE AIR FORCE
AIR UNIVERSITY
AIR FORCE INSTITUTE OF TECHNOLOGY

Wright-Patterson Air Force Base, Ohio

AFIT/GOR/ENS/98M-25

USING BAYESIAN STATISTICS

IN OPERATIONAL TESTING

THESIS

Thuan H. Tran, Captain, USAF

AFIT/GOR/ENS/98M-25

Approved for public release; distribution unlimited

AFIT/GOR/ENS/98M-25

USING BAYESIAN STATISTICS IN OPERATIONAL TESTING

THESIS

Presented to the Faculty of the Graduate School of
Engineering
of the Air Force Institute of Technology
Air University

In Partial Fulfillment of the Requirements for the
Degree of Master of Science in Operations Research

Thuan H. Tran, B.S.

Captain, USAF

March 1998

Approved for public release; distribution unlimited

USING BAYESIAN STATISTICS IN OPERATIONAL TESTING

Thuan H. Tran, B.S.

Captain, USAF

COMMITTEE:

Signature

Co-Advisor

William P. Murdock
Assistant Professor of Operations Research
Department of Operational Sciences
Air Force Institute of Technology



Co-Advisor

Edward A. Pohl
Assistant Professor of Systems Engineering
Department of Operational Sciences
Air Force Institute of Technology



Reader

Edward F. Mykytka
Professor of Operations Research
Department of Operational Sciences
Air Force Institute of Technology

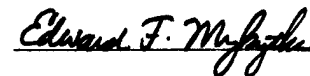

Acknowledgments

The research and writing of this thesis was a team effort even though the title page lists me as the sole author. My co-advisors, Maj Pohl and Maj Murdock, gave me the freedom to work alone and knew when to step in with a word of encouragement or suggestion. I am deeply indebted to my co-advisors for their invaluable advise. My reader, Dr Mykytka, provided me with valuable insights from his comments on the draft of this thesis.

My parents, Mr Nguyen Tran and Mrs Mung Nguyen, as well as my younger brother, An Tran, and younger sister, Tam Tran, provided me with much needed prayer and steadfast moral support through their regular phone call from New Jersey.

Finally, I'd like to express my deep appreciation to a very special person, Miss Hong Phuong Nguyen. She and her parents, Mr Phan Nguyen and Mrs Hoa Nguyen, helped me get through a very difficult time period when I underwent a surgical procedure to remove what turned out to be two "benign tumors" inside my throat. I am deeply grateful that her family treats me as a family member and helped keep me going through the long hours of hard work. Hong also read the draft of this report at several stages.

Table of Contents

	Page
Acknowledgments	iv
Table of Contents	v
List of Figures	viii
List of Tables	xi
Abstract	xi
I. Introduction	1
General Issue	1
Problem Statement	3
Research Objectives.....	3
Scopes	3
II. Literature Review	5
Overview	5
Two Views of Probability	5
Classical Statistical Inference	8
Bayesian Statistical Inference	10
Bayesian Reliability Testing Approach	11
III. Methodology	15
Overview	15
The Binomial Model	16
The Classical Binomial Method.....	16
The Bayesian Binomial Method.....	17
The Exponential Model	20

	The Classical Exponential Method	20
	The Bayesian Exponential Method.....	21
	Reliability Analysis Of A Series System	26
	Reliability Analysis Of A Parallel	28
	Reliability Analysis Of A Bridge System	30
IV.	Results	32
	Overview	32
	The Binomial Model	32
	The Exponential Model	34
	Reliability Analysis Of A Series System	38
	Reliability Analysis Of A Parallel System With Independent And Identical Components	47
	Reliability Analysis Of A Parallel System With Different Independent Components	53
	Reliability Analysis Of A Bridge System With Independent And Identical Components	57
	Reliability Analysis Of A Bridge System With Different Independent Components	63
	Summary	67
V.	Conclusions	69
Appendix A.	Calculation For The Binomial Model	72
Appendix B.	Calculation For The Exponential Model ...	74
Appendix C.	Simulated Data For Series System	77
Appendix D.	Calculation For Series System Reliability	83
Appendix E.	Simulated Data For Parallel System With Independent And Identical Components	93

Appendix F.	Calculation For Parallel System Reliability With Independent And Identical Components	99
Appendix G.	Simulated Data For Parallel System With Different Independent Components	103
Appendix H.	Calculation For Parallel System Reliability With Different Independent Components	115
Appendix I.	Simulated Data For A Bridge System With Independent And Identical Components	122
Appendix J.	Calculation For A Bridge System Reliability With Independent And Identical Components	128
Appendix K.	Simulated Data For A Bridge System With Different Independent Components	141
Appendix L.	Calculation For A Bridge System Reliability With Different Independent Components	147
Bibliography		158
Vita		161

List of Figures

Figure		Page
1.	Five Components Bridge System	30
2.	Classical And Bayesian Reliability Estimates	37
3.	Comparison Of OA Interval Widths	37
4.	OT&E Reliability Using Bayesian Method 1 ...	43
5.	Classical And Bayesian Reliability Estimates	44
6.	Comparison Of OT&E Interval Widths (System Level)	45
7.	Comparison Of OT&E Interval Widths (Component Level)	46
8.	Classical And Bayesian Reliability Estimates	50
9.	Comparison Of OT&E Interval Widths (Aggregated Level)	52
10.	Comparison Of OT&E Interval Widths (Component Level)	52
11.	Classical And Bayesian Reliability Estimates	56
12.	Comparison Of OT&E Interval Widths	57
13.	Classical And Bayesian Reliability Estimates	60
14.	Comparison Of OT&E Interval Widths (Aggregated Level)	62
15.	Comparison Of OT&E Interval Widths (Component Level)	62
16.	Classical And Bayesian Reliability Estimates	66
17.	Comparison Of OT&E Interval Widths	67

List of Tables

Table		Page
1.	A Summary Of Certain Characteristics Of The Sampling Theory And Bayesian Methods of Statistical Inference	7
2.	Summary Of Binomial Results	33
3.	OT&E Data	34
4.	OA Data	34
5.	Summary Of Exponential Results	36
6.	System Level DT Data	39
7.	System Level OT Data	39
8.	Component Level DT Data	40
9.	Component Level OT Data	40
10.	System Reliability Using System Level Data ..	41
11.	System Reliability Using Component Level Data	42
12.	Aggregated Component Level DT Data	47
13.	Aggregated Component Level OT Data	47
14.	Component Level DT Data	48
15.	Component Level OT Data	48
16.	System Reliability Using Aggregated Data	49
17.	System Reliability Using Component Level Data	50
18.	Component Level DT Data	54
19.	Component Level OT Data	54
20.	System Reliability Using Component Level Data	55
21.	Aggregated Component Level DT Data	58

22.	Aggregated Component Level OT Data	58
23.	Component Level DT Data	58
24.	Component Level OT Data	58
25.	System Reliability Using Aggregated Data	59
26.	System Reliability Using Component Level Data	60
27.	Component Level DT Data	64
28.	Component Level OT Data	64
29.	System Reliability Using Component Level Data	65

Abstract

HQ Air Force Operational Test and Evaluation Center (AFOTEC) is responsible for the operational test and evaluation of major weapon systems during their acquisition phase. In operational testing at AFOTEC, it is often the case that not enough data or samples are available to make high confidence classical inferences on various statistics. The use of Bayesian statistical methods may be a solution in which higher confidence inferences can be made on statistics by using other sources of data.

This research explored the applicability of Bayesian methods to the problem of determining the reliability of a series system, a parallel system, and a bridge system. The time to failure of each component in each system is assumed to be exponentially distributed. A basic exponential case and a basic binomial case are also evaluated.

In general, using simulated data and real data when possible, the Bayesian methods produced confidence intervals that were much tighter than the classical inference methods, thus allowing a decision maker to have higher confidence in making a decision. System level data and aggregated component level data produced a much tighter confidence interval than component level data aggregated to system.

USING BAYESIAN STATISTICS IN OPERATIONAL TESTING

I. Introduction

General Issue

In operational testing at the Air Force Operational Test and Evaluation Center (AFOTEC), it is often the case that not enough data or samples are available to make high confidence classical inferences on various statistics. The use of Bayesian statistical methods may be a solution in which higher confidence inferences can be made on statistics by using other sources of data.

The testing of new weapons systems in the Air Force is divided into two types of testing: Developmental Test and Evaluation (DT&E) and Operational Test and Evaluation (OT&E). In developmental testing, the contractor participates directly with the DT&E test agency and the goal is to produce a workable system. However in the operational testing phase, AFOTEC performs independent tests to ensure the system meets Air Force standards and requirements and is ready for production. Traditionally these two types of testing were separate, but with the new call for streamlined acquisition and reduction of testing funds, AFOTEC has to look at incorporating DT&E data into OT&E.

At present, AFOTEC will use DT&E data only when DT&E data was collected by sources that are independent of, and

not influenced by, the contractor. Additionally, AFOTEC has to make sure the data from the DT&E system was from a system configured like the system to be used in OT&E.

Bayesian statistics incorporates "prior information", such as engineering estimates and DT&E data, into making statistical inferences. For example, let $f(y|U)$ be the probability distribution function (pdf) for the time to failure for a component, where y is the data and U is a parameter of the pdf. To utilize prior information, Bayesian statistics assume that the parameter U is indeed a random variable in itself, with its own pdf. Bayesian statistics call the distribution of the random variable U an *a priori* or a *prior* pdf. This prior pdf is called $g(U)$, which expresses the state of knowledge (or ignorance) about U before any new sample data is analyzed. There are various methodologies to convert prior information, such as engineering estimates and DT&E data, into a prior distribution. Then given the prior distribution $g(U)$, the probability distribution $f(y|U)$, and the new data y , Bayes' theorem can be used to calculate the so-called *posterior* pdf $g(U|y)$. The posterior distribution $g(U|y)$ is in a sense, the updated prior distribution. The posterior distribution can now be used to update the pdf, $f(y|U)$, the time to failure distribution.

Problem Statement

Can a system reliability analysis based on Bayesian statistics using DT&E data be used to reduce the number of samples and test time needed for OT&E and provide the same or better confidence levels than classical statistical inference methods?

Research Objectives

The objectives of this research are: 1) to investigate different Bayesian methods and various weighting schemes for using prior information; 2) develop a methodology for using Bayesian statistics with DT&E data to predict system reliability based on data obtained from a program which is in the process of transition from development to production and compare the results with those obtained from classical statistical methods.

Scope

This research will use DT&E and OT&E reliability data obtained from a test program when possible. Simulated reliability data will be used to verify and validate the methodology. This research will concentrate mainly on the exponential case. This research is limited to exploring the applicability of Bayesian statistical methods to the problem of determining the reliability of a series system, a parallel system, and a bridge system. The time to failure

of each component in each system is assumed to be exponentially distributed. A basic exponential case and a basic binomial case are also evaluated. The methodology developed in this research is based on the assumption that both DT&E and OT&E data are available. The next chapter will identify and discuss some of the different approaches of Bayesian statistics as well as comparing and contrasting these with the classical inference method.

II. Literature Review

Overview

This chapter will begin with the classical statistical inference and Bayesian statistical inference approaches. The chapter concludes with current thinking on the use of Bayesian statistical concepts for the type of reliability analysis found in the literature.

Two Views of Probability

In the classical method, the probability of an event is defined as the relative frequency of an event occurring during repeated runs of an experiment. Let S be the set of all possible outcomes of an experiment. Let A be one of the possible outcomes. The classical method defines the probability of A (the likelihood of outcome A happening) as $P[A] = \lim_{n \rightarrow \infty} (a/n)$, where a is the number of times outcome A occurs during n runs of the experiment. The value of $P[A]$ is an unknown constant that can be estimated if enough runs of the experiment are conducted. This classical view is also known as the "frequentist" viewpoint (14:50).

The Bayesian method defines probability subjectively. In contrast to the classical method, the Bayesian method does not consider $P[A]$ to be an objective estimate of the likelihood of outcome A . Instead the Bayesian method considers $P[A]$ as a rational expression of one individual's

degree of belief that outcome A will occur. Different values of $P[A]$ based on different perceptions of prior experience can be assigned by different individuals. This does not mean the Bayesian method abandons experimentation. Experimentation provides an important tool for an individual to refine their assessment of $P[A]$ (14:50-51).

Consider the following experiment: a coin is flipped, with the outcome to be "head" or "tail" ($S = \{\text{head}, \text{tail}\}$). Let the event $A = \{\text{head}\}$. To find $P[A]$, the classical method would require n flips of the coin (n large), count the m occurrences of $A = \{\text{head}\}$, and compute $P[A]$ to be approximately m/n . In contrast, the Bayesian method might declare that $P[A] = 0.5$ based on experience with similar coins that a "head" is as likely to occur as a "tail" in any flip. To validate and refine the estimate, a number of experimental flips of the coin would then be made.

There are distinctive differences between classical statistical inference and Bayesian statistical inference methods. The classical statistical inference uses inductive reasoning while the Bayesian method uses deductive reasoning. The Bayesian method takes into account prior information while the classical method only considers the prior information in an informal manner, if at all. The classical method is more restrictive due to the exclusive

use of sample data. To achieve the same level of inferences, the Bayesian method usually requires less sample data as compared to the classical method. When sample data is expensive or difficult to obtain, as reliability data often is, the Bayesian method has the advantage of being able to use prior information. Table 1 summarizes the characteristics of the two approaches.

Table 1. A Summary of Certain Characteristics of the Sampling Theory and Bayesian Methods of Statistical Inference (6:169)

Characteristic	Sampling Theory	Bayesian
Parameter(s) of Interest	Unknown constant(s)	Random Variable(s)
Prior Distribution	Does not exist	Exists and explicitly assumed
Sampling Model	Assumed	Assumed
Posterior Distribution	Does not exist	Explicitly derived
Method of Reasoning	Inductive	Deductive
Type of Interval Estimate	Confidence interval	Probability interval
Role of Past Experience	Not applicable	Applicable
Purpose of Sampling Experience	Supply data for making inferences	Confirm or deny expected performance as predicted from past experience
Quality of Inferences	More restricted than Bayes' because of exclusive use of sample data	Depends on ability to quantitatively relate past experience to the sample data
Quantity of Sample Data		Bayes' approach usually requires less because it utilizes relevant past data

Martz and Waller identify four advantages for using the Bayesian method: 1) increased quality of the inferences, provided the prior information accurately reflects the true variation in the parameters; 2) reduction in testing requirements (test time and/or sample size); 3) inferences that are unacceptable must come from incorrect assumptions and not from inadequacies of the method used to provide the inferences; and 4) the rules for manipulating probability statements on components into corresponding statements on system reliability are well known, whereas equivalent rules for manipulation of confidence statements are not (6:172-3).

Classical Statistical Inference.

Let the population be defined as the total number of systems in use for a particular system. When it is not practical to test all members of a population, a subset or sample of systems can be selected from the population for testing. The sample is presumed to be randomly selected such that each system having an equal chance of being in the sample.

Two types of inferences can be drawn from the sample. A point estimate approximates the true value of the population parameter with a single value. However, this single value of a point estimate does not provide any information about the uncertainty associated with that

estimate. To account for uncertainty, an interval estimate provides an estimate that the sample statistic is within a certain interval about the true population parameter. Consider the mean of a sample, \bar{x} , which is a point estimate of the population mean. Compared with the true population mean μ , \bar{x} will differ by some unknown sampling error amount ϵ . Thus $\bar{x} = \mu + \epsilon$ or $\bar{x} = \mu - \epsilon$. For large sample sizes, both the sampling distribution and sampling error distribution are approximately normal by the Central Limit Theorem. From this, a confidence interval based on the population standard error, σ , is developed. The population standard error is the deviations or distances of the population measurements from their mean.

$$(\bar{x} - z*\sigma) < \mu < (\bar{x} + z*\sigma) \quad (1)$$

where z is the critical value associated with a specified probability. The population standard error is usually not known in most cases. However, it can be estimated by using the sample standard error, s with

$$s = \left(\frac{1}{m}\right) \sum_{i=1}^m (X_i - \bar{X})^2 \quad (2)$$

$$\text{and } \bar{X} = \left(\frac{1}{m}\right) \sum_{i=1}^m X_i . \quad (3)$$

Thus an approximate confidence interval is obtained using s .

Bayesian Statistical Inference

Bayes' Theorem. Bayes' theorem (6:174-5) can be written as:

$$g(\theta|x) = \frac{f(x|\theta)g(\theta)}{f(x)} \quad (4)$$

where θ is the population parameter

$g(\theta|x)$ is the posterior probability distribution of θ given sample data x

$g(\theta)$ is the prior probability distribution of θ

$f(x|\theta)$ is the probability of observing sample data x given the true parameter θ

$f(x)$ is the marginal probability distribution of x .

$f(x)$ can be obtained by

$$f(x) = \begin{cases} \int f(x|\theta)g(\theta)d\theta, & \theta \text{ continuous} \\ \sum f(x|\theta)g(\theta), & \theta \text{ discrete.} \end{cases}$$

The Prior Distribution. Bayesian inference is appropriate only when the prior assessment of θ is accurate. Great care must be exercised when selecting the prior density $g(\theta)$. The prior density can take any form. However, natural conjugate priors and noninformative priors (also called priors of ignorance) are used in most practical applications. When using a natural conjugate prior, the posterior distribution is in the same family as the prior distribution and can be obtained simply by using analytical tools. When there is little or no information on the value

of a parameter, a noninformative prior is used. The most commonly used is the uniform distribution. For a detailed discussion of the noninformative prior, see Press (8:46-51). For the continuous prior distribution, discretization is often used to allow for more tractable data manipulation. Chay (1) argues that since numerical integration can be done using computer calculations, it is not necessary to approximate continuous prior distributions using discretization. The process of determining the form of $g(\theta)$ is difficult and controversial. When selecting a prior, it must be both reasonable and justifiable.

Bayesian Reliability Testing Approaches. In this section, current approaches in applying Bayesian methods in reliability testing will be addressed.

Chen and Papadopoulos (2) proposed a Bayesian method for a generalized exponential failure model for components in a parallel or series system. The gamma or uniform distribution is used as a prior. The generalized failure models under consideration are the exponential, Weibull, Rayleigh, and as a special case, the extreme value failure model. Sharma and Bhutani (11) considered a parallel system composed of independent and identical components whose failure distribution was exponentially distributed. The exponential distribution is used as a prior. Villacourt and

Mahaney (12) used the Bayesian method to design a reliability demonstration test on a lithography expose tool. The failure times are assumed to be exponentially distributed. The gamma distribution is used as a prior.

Martz, Waller, and Fickas (7) developed a Bayesian procedure for a series system of binomial subsystems and components. Test or prior data (perhaps both or neither) at the system, subsystem, and component level are considered. The beta distribution is used as a prior. The method was used to estimate the overall reliability of an air-to-air heat seeking missile system with five major subsystems and up to nine components per subsystem. Martz and Waller (5) extended the method to cover the case of a complex series/parallel systems of binomial subsystems and components. These methods are very complex and difficult to implement.

Willits, Dietz, and Moore (15) show that for a series-system, reliability estimates using very small sets (less than 10 data points) of binomial test-data, there is no clear advantage of using Bayes interval estimation unless the prior mean system reliability is believed to be within 20 percent of the true system reliability. A classical method for very small samples, the Linstrom-Madden estimator, should be used.

When both prior and current data are available, which is the case in this research, the methods mentioned above in general are not applicable. However, studying these methods provided the general knowledge of understanding how Bayesian statistical methods worked.

In this research, the applicability of Bayesian statistical methods to the problem of determining the reliability of a series system, a parallel system, and a bridge system is being studied. The time to failure of each component in each system is assumed to be exponentially distributed. A basic exponential case and a basic binomial case are also evaluated. There is very little information concerning the use of Bayesian methods to the systems mentioned above in the literature. The methodology being developed in Chapter III is based on the works of the following individuals.

Lemaster (4) studied the applicability of Bayesian method to the problem of determining cruise missile component reliability. The exponential and binomial distributions were used for the failure rate. For the exponential case, a gamma prior is used. For the binomial case, a beta prior is used.

Sharma and Bhutani (10) considered the case for a series system when the failure time for the system is

exponentially distributed. The gamma distribution is used as a prior.

Frickenstein (3) studied the case for a simple system (one component) when the failure time for the system is assumed to be exponentially distributed. The gamma distribution is used as a prior.

The text book, Bayesian Reliability Analysis, written by Martz and Waller (6) is the standard reference work on Bayesian statistical methods and will be used extensively in this research effort. The binomial model developed in Chapter III is based on the methods developed by Lemaster (4) with modifications based on Martz and Waller (6). The exponential model developed in Chapter III is based on the methods developed by Lemaster (4) and by Frickenstein (3) with modifications based on Martz and Waller (6).

Reliability analysis methods for a series system, a parallel system, and a bridge system (with the time to failure of each component in each system is assumed to be exponentially distributed) are developed in Chapter III utilizing the exponential model. For the series system, the Bayesian methods developed by Sharma and Bhutani (10) will also be modified for use in this research. The next chapter will discuss the methodology used in this research to accomplish the research objectives stated in Chapter I.

III. Methodology

Overview.

This chapter details the methodology used to accomplish the research objectives stated in Chapter I. The methodology developed in this chapter is based on the assumption that both DT&E (prior) and OT&E (current) data are available. A basic binomial model and a basic exponential model are developed first. The basic exponential model is then applied to the problem of determining the reliability of a series system, a parallel system, and a bridge system. The time to failure of each component in each system is assumed to be exponentially distributed. Classical and Bayesian point estimates and confidence intervals obtained from each system will be compared in Chapter IV.

Data Source.

For the basic binomial model, a hypothetical set of missile test data will be used to validate the methodology. For the basic exponential model, the model is applied to data obtained by AFOTEC during a reliability testing of a selected simple system (system is treated as one component) with the time to failure of the system is assumed to be exponentially distributed. This is the only set of true data used in this research. Simulated data will be used to

validate the methodology for a series system, a parallel system, and a bridge system. This research uses a computer program called RAPTOR (Rapid Availability Prototyping for Testing Operational Readiness), which is developed by AFOTEC, to simulate the true system (series, parallel, bridge) mentioned above. RAPTOR is verified and validated by AFOTEC and is an excellent tool for use in this research effort.

The Binomial Model.

This model is appropriate for systems or components that are assumed to have binomial failure distribution. The classical binomial method is given first. Then the Bayesian binomial method is given based on the assumption that both prior data (DT&E data) and current data (OT&E data) are available. The model is then applied to a hypothetical missile launch problem in Chapter IV.

The Classical Binomial Method.

The binomial distribution is one of the commonly used distribution in reliability. Consider a missile system that is being tested with the outcome of each test as the missile success or failure to launch. Assuming a missile system has the binomial distribution, the point estimate for the probability of success p (which is the reliability of a missile system) and 80% confidence interval about p will be

computed. For the binomial distribution, the point estimate using the maximum likelihood estimator is

$$\hat{p} = \left(\frac{X}{n} \right) \quad (5)$$

where X is the number of successes from a set of n missile units placed into a test of given duration (6:53). The confidence limits can be approximated by using the F distribution. The 100(1 - γ)% two-sided confidence interval (TCI) is (6:56)

$$\left(\frac{X}{X+(n-X+1)F_{1-\gamma/2}(2n-2X+2, 2X)}, \frac{(X+1)F_{1-\gamma/2}(2X+2, 2n-2X)}{(n-X)+(X+1)F_{1-\gamma/2}(2X+2, 2n-2X)} \right) \quad (6)$$

The Bayesian Binomial Method.

Since they are relatively easy to compute and can be adapted to a number of situations, the family of beta distributions, B(x,n), are used for the binomial case to calculate both the prior and posterior distributions. For example, the analyst's knowledge and experience with the system is utilized to select x and n. Thus the analyst can increase or decrease the importance of the prior on the resulting posterior distribution (4:39).

Bayesian Binomial Prior. For the binomial sampling, a B(x₀,n₀) distribution can be used to maximize flexibility and make it easier to calculate the posterior distribution since the B(x₀,n₀) distribution is the natural conjugate prior distribution. The parameters x₀ and n₀ can

be interpreted as the *pseudo number of survivals* and *pseudo sample size* for the prior life test. Here "pseudo" should be thought of as meaning "pretended" (6:265). When the true prior distribution is not of the beta family, Weiler (13) showed that assuming a $B(x_0, n_0)$ distribution is acceptable in many practical applications. Weiler was able to show that severe deviations from the beta prior parameter values will result in minor changes in the corresponding posterior distributions. DT&E data will be used to approximate x_0 and n_0 that fit the $B(x_0, n_0)$ distribution. For the missile launch problem in Chapter IV where the outcome of each test is a missile success or failure to launch, x_0 is the number of successes during DT&E test and similarly n_0 is the total number tested.

Bayesian Binomial Posterior. For the $B(x_0, n_0)$ prior distribution, the resulting posterior distribution is also a beta distribution of the form $B(x + x_0, n + n_0)$, where x is the observed successes and n is the sample size from the test being used to update the prior. The probability density function (6:266) is given as

$$g(p|x; x_0, n_0) = \left(\frac{\Gamma(n+n_0)}{\Gamma(x+x_0)\Gamma(n+n_0-x-x_0)} \right) p^{(x+x_0)-1} (1-p)^{(n+n_0-x-x_0)-1} \quad (7)$$

where $0 < p < 1$.

Bayesian Binomial Point Estimate. The mean of the posterior distribution is the Bayesian point estimator. Under the squared error loss function, the Bayesian point estimator is (6:267)

$$\hat{p} = E(p|x; x_0, n_0) = \left(\frac{x+x_0}{n+n_0} \right). \quad (8)$$

The loss function measures the error sustained by estimating p by \hat{p} . The squared error loss function often used in practical application is $(\hat{p} - p)^2$ (14:56).

Bayesian Binomial Probability Interval. The Bayesian methods use "probability intervals" instead of "confidence intervals". Recall that the classical method assumes that the parameter p estimated is an unknown constant. Thus the estimators of the end points of the confidence interval associated with p estimated are random variables. A classical confidence interval is not an explicit probability statement about p . However, it is "the probability that the interval estimator will generate an interval that will contain the true value of p " (14:57). In contrast, Bayesian method considers p to be a random variable. Thus a Bayesian probability interval is an explicit probability statement about the value of p (6:208).

Using the $F(n_1, n_2)$ distribution, the Total Bayesian Probability Interval (TBPI) can be calculated. A 80%

confidence interval will be calculated. For the $100(1 - \gamma)\%$ TBPI, the upper and lower interval endpoints are (6:270)

$$\left(\frac{\frac{x+x_0}{x+x_0+(n+n_0-x-x_0)F_{1-\gamma/2}(2n+2n_0-2x-2x_0, 2x+2x_0)'}}{(x+x_0)F_{1-\gamma/2}(2x+2x_0, 2n+2n_0-2x-2x_0)} \right) . \quad (9)$$

$$\left(\frac{(x+x_0)F_{1-\gamma/2}(2x+2x_0, 2n+2n_0-2x-2x_0)}{n+n_0-x-x_0+(x+x_0)F_{1-\gamma/2}(2x+2x_0, 2n+2n_0-2x-2x_0)} \right)$$

The Exponential Model.

This model is appropriate for systems or components that are assumed to have exponential failure distribution. The classical exponential method is given first. Then the Bayesian exponential method is given based on the assumption that both prior data (DT&E data) and posterior data (OT&E data) are available. In Chapter IV, the model is applied to data obtained by AFOTEC during a reliability testing of a selected simple system with the time to failure of the system is assumed to be exponentially distributed.

The Classical Exponential Method.

The exponential distribution is the most widely used distribution in reliability. Assuming the time to failure of a system or component has the exponential distribution, point estimates for the failure rate λ and 80% confidence intervals on λ will be computed. For the exponential distribution, the point estimate of λ using the maximum likelihood estimator is

$$\hat{\lambda} = \left(\frac{f}{T} \right) \quad (10)$$

where f is the number of failures and T is the total test time. The number of failures, f , is presumed to be a random variable. The confidence limits can be approximated by using the chi square χ^2 distribution. The $100(1 - \gamma)\%$ two-sided confidence interval (TCI) is (6:122)

$$\left(\frac{\chi_{\gamma/2}^2(2f)}{2T}, \frac{\chi_{1-\gamma/2}^2(2f)}{2T} \right) . \quad (11)$$

For the reliability function $R(t) = \exp(-\lambda t)$, the reliability estimator of $R(t)$ for a mission time t is

$$\hat{R}(t) = \exp(-\hat{\lambda} t) \quad (12)$$

where t is the mission length.

Equation 12 is also used to calculate an interval estimate of $\hat{R}(t)$ by using the lower and upper bound of $\hat{\lambda}$ obtained from Equation 11 in place of $\hat{\lambda}$.

The Bayesian Exponential Method.

When examining a continuously operating electronic system, the failure time is often assumed to be exponentially distributed. The distribution of the number of failures, f , in fixed total test time, T , can be described by the Poisson distribution (6:255) as

$$p(f \text{ failures in total time } T | \lambda) = \left(\frac{e^{-\lambda T} (\lambda T)^f}{f!} \right) \quad (13)$$

where $\lambda, T > 0$, $f = 0, 1, 2, \dots$ and assuming that failed items are replaced. This is known as Poisson sampling.

Bayesian Exponential Prior. For the Poisson sampling, a gamma prior distribution, $G(\alpha, \beta)$, may be used to maximize flexibility and make it easier to calculate the posterior distribution since the $G(\alpha, \beta)$ distribution is the natural conjugate prior distribution (6:289). The $G(\alpha, \beta)$ prior distribution is probably the most widely used and has the following probability density function:

$$g(\lambda; \alpha, \beta) = \left(\frac{\beta^\alpha \lambda^{\alpha-1} e^{-\beta\lambda}}{\Gamma(\alpha)} \right) \quad (14)$$

where λ, α , and $\beta > 0$ and $\Gamma(\alpha)$ is the gamma function of α .

The shape parameter α can be interpreted as the *pseudo number of failures* in a prior life test of duration β *pseudo time units* (6:289). The mean and variance of the gamma distribution are

$$E(\lambda) = \left(\frac{\alpha}{\beta} \right) \quad (15)$$

$$\text{and } V(\lambda) = \left(\frac{\alpha}{\beta^2} \right). \quad (16)$$

$E(\lambda)$ and $V(\lambda)$ can be estimated using the sample mean and variance of λ respectively with $E(\lambda) = \bar{\lambda}$ and $V(\lambda) = s_\lambda^2$.

Equations 2 and 3 (page 9) are used to compute $\bar{\lambda}$ and s_{λ}^2 .

Thus α and β can be computed as

$$\alpha = \left(\frac{E^2(\lambda)}{V(\lambda)} \right) \quad (17)$$

$$\text{and } \beta = \left(\frac{E(\lambda)}{V(\lambda)} \right). \quad (18)$$

Bayesian Exponential Posterior. For the $G(\alpha, \beta)$ prior distribution, the resulting posterior distribution is a $G(f + \alpha, T + \beta)$, where f is the number of failures and T is the total test time. The probability density function (6:290) is given as

$$g(\lambda|f; \alpha, \beta) = \left(\frac{(T + \beta)^{f + \alpha} \lambda^{f + \alpha - 1} e^{-(T + \beta)\lambda}}{\Gamma(f + \alpha)} \right) \quad (19)$$

where $\lambda > 0$. The parameter $(f + \alpha)$ is referred as the *combined number of failures* and $(T + \beta)$ is the *combined total test time*.

Bayesian Exponential Point Estimate. The mean of the posterior distribution is the Bayesian point estimator. Under the squared error loss function, the Bayesian point estimator is

$$\hat{\lambda} = E(\lambda|f; \alpha, \beta) = \left(\frac{f + \alpha}{T + \beta} \right) \quad (20)$$

where $(f + \alpha)$ is the combined number of failures and $(T + \beta)$ is the combined total test time (6:292).

Bayesian Exponential Probability Interval. For the 100(1 - γ)% TBPI, the upper and lower interval endpoints are (6:294)

$$\left(\frac{\chi_{\gamma/2}^2(2f+2a)}{2(t+\beta)}, \frac{\chi_{1-\gamma/2}^2(2f+2a)}{2(t+\beta)} \right) \quad (21)$$

For the reliability function $R(t) = \exp(-\lambda t)$, the Bayesian estimator of $R(t)$ for a mission time t is (3:8)

$$\begin{aligned} \hat{R}(t) &= E[R(t) | f] = \int_0^{\infty} \exp(-\lambda t) g(\lambda | f; a, \beta) d\lambda \\ &= \left(\frac{\left(\frac{T}{\beta} \right) + 1}{\left(\frac{T}{\beta} \right) + \left(\frac{t}{\beta} \right) + 1} \right)^{a+f} \end{aligned} \quad (22)$$

where f is the number of failures, T is the total test time and t is the mission time.

Another way of computing the Bayesian estimator of $R(t)$ is $\hat{R}(t) = \exp(-\hat{\lambda}t)$. Both methods should yield very similar result. Mathematically speaking, Equation 22 is selected for use since it is directly derived. The reliability function $R(t) = \exp(-\lambda t)$ is also used to calculate an interval estimate of $\hat{R}(t)$ by using the lower and upper bound of $\hat{\lambda}$ obtained from Equation 21 in place of $\hat{\lambda}$.

Bayesian Weibull Method. If the true distribution of the time to failure is not exponentially distributed, the Bayesian method can still be developed but it is a lot

harder to do the number calculation. Another frequently used time to failure distribution is the Weibull distribution. The Bayesian Weibull method described below shows how difficult it can be to do this calculation.

If the prior distribution of λ is the two-parameter Weibull distribution with probability density function (6:300)

$$g(\lambda; \alpha, \beta) = \left(\frac{\beta}{a}\right) \left(\frac{\lambda}{a}\right)^{\beta-1} \exp\left(-\left(\frac{\lambda}{a}\right)^\beta\right) \quad \lambda, \alpha, \beta > 0 \quad (23)$$

where α is the scale parameter and β is the shape parameter.

For the Weibull prior distribution, the resulting posterior probability density function (6:300) is given as

$$g(\lambda|f; \alpha, \beta) = \left(\frac{\lambda^{f+\beta-1} e^{-\lambda T - (\lambda/a)^\beta}}{\int_0^\infty \lambda^{f+\beta-1} e^{-\lambda T - (\lambda/a)^\beta} d\lambda} \right) \quad \lambda > 0 \quad (24)$$

where f is the number of failures and T is total test time.

For the Weibull prior distribution, the resulting posterior mean (6:300) is given as

$$\hat{\lambda} = E(\lambda|f; \alpha, \beta) = \left(\frac{\int_0^\infty \lambda^{f+\beta} e^{-\lambda T - (\lambda/a)^\beta} d\lambda}{\int_0^\infty \lambda^{f+\beta-1} e^{-\lambda T - (\lambda/a)^\beta} d\lambda} \right) \quad \lambda > 0. \quad (25)$$

Both equations given above must be numerically evaluated. Due to the difficulty associated with numerical evaluation, the Weibull prior will not be used in this thesis.

Reliability Analysis of a Series System.

Consider a system composed of k independent components in series configuration. The time to failure of each component is assumed to be exponentially distributed. Let $\lambda_1, \lambda_2, \dots, \lambda_k$ be the respective constant failure rates of each component. The failure rate for the system is (10:761)

$$\lambda = \sum_{i=1}^k \lambda_i. \quad (26)$$

This shows that for a system composed of k independent exponentially distributed components in series configuration, the distribution of the failure time of the system is also exponential with failure rate λ .

The Bayesian Method 1 (10:761-763).

Bayesian Prior Analysis. Assuming that the prior belief about the failure rates λ_i ($i = 1, 2, \dots, k$) is exponentially distributed with parameter θ . Then the prior

belief about $\lambda = \sum_{i=1}^k \lambda_i$ is defined by a gamma distribution

with probability density function (10:761)

$$g(\lambda) = \left(\frac{\theta^k \lambda^{k-1} e^{-\theta\lambda}}{\Gamma(k)} \right) \quad \lambda, \theta, k > 0. \quad (27)$$

The mean and the variance for the failure rate of the system are $E(\lambda) = k/\theta$ and $V(\lambda) = k/\theta^2$.

Bayesian Posterior Analysis. For a system with failure time being exponentially distributed with failure rate λ , then for the accumulated test time T , the number of system failures f is Poisson distributed with pdf (10:761)

$$P(f|\lambda) = \left(\frac{(T\lambda)^f e^{-T\lambda}}{f!} \right) \quad f = 0, 1, 2, \dots \quad (28)$$

Thus the posterior probability density function for λ given f failures over a time interval $(0, T)$ with respect to a gamma prior given above is (10:761-762)

$$P(\lambda|f) = \left(\frac{(T+\theta)^{f+k} e^{-(T+\theta)\lambda} \lambda^{f+k-1}}{\Gamma(f+k)} \right) \quad \lambda, (T+\theta), (f+k) > 0 \quad (29)$$

which is also a gamma with parameters $(T+\theta)$ and $(f+k)$. The Bayesian estimator of λ given f failure in T hours of testing is (10:762)

$$\hat{\lambda} = E(\lambda|f) = \left(\frac{f+k}{T+\theta} \right). \quad (30)$$

For the reliability function $R(t) = \exp(-\lambda t)$, the Bayesian estimator of $R(t)$ for a mission time t given f failures in T hours of testing is (10:762)

$$\hat{R}(t) = E[R(t)|f] = \left(\frac{1}{1 + \left(\frac{t}{T+\theta} \right)} \right)^{f+k}. \quad (31)$$

Using The Exponential Model. This method uses the Exponential Model given above to calculate the classical and Bayesian reliability point estimates, R_i ($i = 1 \dots k$), and

the classical and Bayesian component reliability confidence intervals, (LB_i, UB_i) . LB_i is the interval lower bound and UB_i is the interval upper bound for each component. The next step is to aggregate the appropriate numbers together to obtain the classical and Bayesian system reliability point estimates and the classical and Bayesian system reliability confidence interval, (LB_s, UB_s) . The system reliability point estimate is

$$R_s = \prod_{i=1}^k R_i . \quad (32)$$

The system reliability confidence interval is calculated as

$$LB_s = \prod_{i=1}^k LB_i \quad (33)$$

$$\text{and } UB_s = \prod_{i=1}^k UB_i . \quad (34)$$

The Exponential Model is also used to calculate the classical and Bayesian reliability point estimates and the classical and Bayesian confidence intervals for the system using component level data aggregated to system level data. This is possible since for a series system with exponential components, the failure rate for the system is also exponential and is the sum of the components' failure rates.

Reliability Analysis of a Parallel System.

Consider a system composed of k independent components in parallel configuration. The time to failure of each component is assumed to be exponentially distributed. Let

λ_i ($i = 1 \dots k$) be the respective constant failure rate of each component. This method uses the Exponential Model given above to calculate the classical and Bayesian reliability point estimates, R_i ($i = 1 \dots k$), and the classical and Bayesian component reliability confidence intervals, (LB_i, UB_i) . LB_i is the interval lower bound and UB_i is the interval upper bound for each component. The next step is to aggregate the appropriate numbers together to obtain the classical and Bayesian system reliability point estimates and the classical and Bayesian system reliability confidence intervals, (LB_s, UB_s) . The system reliability point estimate is

$$R_s = 1 - \prod_{i=1}^k (1 - R_i). \quad (35)$$

The system reliability confidence interval is calculated as

$$LB_s = 1 - \prod_{i=1}^k (1 - LB_i) \quad (36)$$

$$\text{and } UB_s = 1 - \prod_{i=1}^k (1 - UB_i). \quad (37)$$

For the case of independent and identical components, The Exponential Model is also used to calculate the classical and Bayesian reliability point estimates, R_c , and the classical and Bayesian confidence intervals, (LB_c, UB_c) for the component using aggregated component level data. This is possible since the failure rate for each component is the same. The system reliability point estimate is

$$R_s = 1 - (1 - R_c)^k. \quad (38)$$

The system reliability confidence interval is calculated as

$$LB_s = 1 - (1 - LB_c)^k \quad (39)$$

$$\text{and } UB_s = 1 - (1 - UB_c)^k. \quad (40)$$

Reliability Analysis of a Bridge System.

Consider a system composed of 5 independent components given in Figure 1 below. The time to failure of each component is assumed to be exponentially distributed.

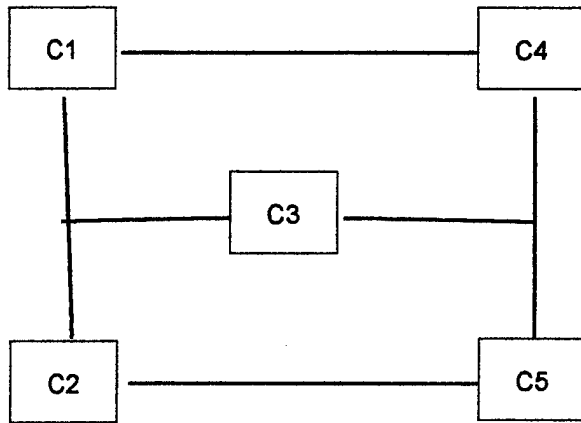

Figure 1. Five Components Bridge System.

Let λ_i ($i = 1 \dots 5$) be the respective constant failure rate of each component. This method used the Exponential Model given above to calculate the classical and Bayesian reliability point estimates, R_i ($i = 1 \dots 5$), and the classical and Bayesian component reliability confidence intervals, (LB_i, UB_i) . LB_i is the interval lower bound and UB_i is the interval upper bound for each component. The next step is to aggregate the appropriate numbers together to

obtain the classical and Bayesian system reliability point estimates and the classical and Bayesian system reliability confidence interval, (LB_s, UB_s) . The system reliability point estimate is (9:422)

$$R_s = R_1R_4 + R_2R_5 + R_1R_3R_5 + R_2R_3R_4 - R_1R_2R_3R_4 - R_1R_2R_3R_5 - R_1R_2R_4R_5 - R_1R_3R_4R_5 - R_2R_3R_4R_5 + 2R_1R_2R_3R_4R_5. \quad (41)$$

The system reliability confidence interval is calculated as

$$LB_s = LB_1LB_4 + LB_2LB_5 + LB_1LB_3LB_5 + LB_2LB_3LB_4 - LB_1LB_2LB_3LB_4 - LB_1LB_2LB_3LB_5 - LB_1LB_2LB_4LB_5 - LB_1LB_3LB_4LB_5 - LB_2LB_3LB_4LB_5 + 2LB_1LB_2LB_3LB_4LB_5 \quad (42)$$

$$\text{and } UB_s = UB_1UB_4 + UB_2UB_5 + UB_1UB_3UB_5 + UB_2UB_3UB_4 - UB_1UB_2UB_3UB_4 - UB_1UB_2UB_3UB_5 - UB_1UB_2UB_4UB_5 - UB_1UB_3UB_4UB_5 - UB_2UB_3UB_4UB_5 + 2UB_1UB_2UB_3UB_4UB_5. \quad (43)$$

For the case of independent and identical components, The Exponential Model is also used to calculate the classical and Bayesian reliability point estimates, R_c , and the classical and Bayesian probability intervals, (LB_c, UB_c) for the component using aggregated component level data. This is possible since the failure rate for each component is the same. The system reliability point estimate is calculated using Equation 41 above with R_c replacing R_i ($i = 1 \dots 5$). The system reliability confidence interval is calculated using Equations 42 and 43 with LB_c replacing LB_i ($i = 1 \dots 5$) and UB_c replacing UB_i ($i = 1 \dots 5$).

IV. Results

Overview.

This chapter describes and discusses the results of the calculations using the methodology in Chapter III. Results from a basic binomial case and a basic exponential case are given first. Then results from a series system, a parallel system with independent and identical components, and a parallel system with different independent components are presented. Finally, results from a bridge system with independent and identical components and a bridge system with different independent components are given. The time to failure of each component in each system is assumed to be exponentially distributed. For detailed calculations, see the appropriate appendix. Calculations will be shown in detail the first time presented in the appropriate appendix. Classical and Bayesian point estimates and confidence intervals obtained from each system will be presented and discussed in this chapter.

The Binomial Model.

Suppose the following data are obtained from a missile test program. For the DT&E portion of the test, two missiles failed out of 20 missiles launched. For the OT&E portion of the test, one missile failed out of 12 missiles launched. Assuming the missile system failures may be

modeled with the binomial distribution, point estimates for the probability of success p (which is the reliability of the missile system) and 80% confidence interval about p will be computed. From the data above, the following results are obtained (for detailed calculation, see Appendix A):

Table 2: Summary of Binomial Results

	Classical	Bayesian
DT&E		
\hat{p}	90.00%	
80% Interval	(75.52% $\leq p \leq$ 97.31%)	
Interval Width	21.79%	
OT&E		
\hat{p}	91.67%	90.63%
80% Interval	(71.25% $\leq p \leq$ 99.13%)	(83.73% $\leq p \leq$ 96.39%)
Interval Width	27.88%	12.66%

Table 2 shows that the point estimates for the probability of success, p , are all very similar. The bounds using classical method are quite large. You are 80% confident that the true p is between 75.52% and 97.31% for DT&E data and between 71.25% and 99.13% for OT&E data. The strength of Bayesian analysis lies in the posterior analysis as the table shows. Although the estimates of p is very close to the estimates of p using classical method, the Bayesian method yields a much tighter range for the point estimate. The probability is 80% that the true p is between 83.73% and 96.39%. Even though the width of the probability interval is still large, it is a significant improvement

compared to the width of the intervals obtained using classical method.

The Exponential Model.

The following data are obtained from a reliability test program of a selected simple system by AFOTEC (assuming the time to failure of the terminals being tested is exponentially distributed). For the OT&E portion of the test, five terminals were tested for a period of seven months. The number of operational hours (T_i) and the number of critical failures per terminal (X_i) were recorded and are given in Table 3.

Table 3: OT&E Data (3:6)

Terminal i	T_i Hours	X_i Failures
1	184.3	12
2	232.6	9
3	172.8	9
4	284.4	17
5	264.8	18

For the operational assessment (OA) portion of the test, two terminals were tested. Again the number of operational hours (T_i) and the number of critical failures per terminal (X_i) were recorded and are given in Table 4.

Table 4: OA Data (3:7)

Terminal i	T_i Hours	X_i Failures
1	68.5	2
2	60.9	2

The reliability of the system for a mission time t will be estimated and 80% confidence intervals associated with the estimated system reliability will be computed using the methodology given in Chapter III. Since the time to failure of the terminals being tested is assumed to be exponentially distributed, a gamma prior distribution is assumed. From the data above, the following results are obtained (for detailed calculation, see Appendix B):

Table 5: Summary of Exponential Results

	Classical	Bayesian
OT&E $\hat{R}(1)$ 80% Interval Interval Width	94.45% (93.58% $\leq R \leq$ 95.29%) 1.71%	
OA $\hat{R}(1)$ 80% Interval Interval Width	96.96% (94.97% $\leq R \leq$ 98.66%) 3.69%	95.03% (93.87% $\leq R \leq$ 96.22%) 2.35%
OT&E $\hat{R}(1.5)$ 80% Interval Interval Width	91.80% (90.53% $\leq R \leq$ 93.02%) 2.49%	
OA $\hat{R}(1.5)$ 80% Interval Interval Width	95.47% (92.55% $\leq R \leq$ 98.00%) 5.45%	92.64% (90.94% $\leq R \leq$ 94.39%) 3.45%
OT&E $\hat{R}(2)$ 80% Interval Interval Width	89.21% (87.58% $\leq R \leq$ 90.81%) 3.23%	
OA $\hat{R}(2)$ 80% Interval Interval Width	94.01% (90.19% $\leq R \leq$ 97.34%) 7.15%	90.32% (88.11% $\leq R \leq$ 92.59%) 4.48%
OT&E $\hat{R}(2.5)$ 80% Interval Interval Width	86.70% (84.72% $\leq R \leq$ 88.65%) 3.93%	
OA $\hat{R}(2.5)$ 80% Interval Interval Width	92.56% (87.89% $\leq R \leq$ 96.68%) 8.79%	88.05% (85.37% $\leq R \leq$ 90.82%) 5.45%
OT&E $\hat{R}(3.5)$ 80% Interval Interval Width	81.89% (79.29% $\leq R \leq$ 84.47%) 5.18%	
OA $\hat{R}(3.5)$ 80% Interval Interval Width	89.75% (83.47% $\leq R \leq$ 95.39%) 11.92%	83.69% (80.13% $\leq R \leq$ 87.39%) 7.26%

Figure 2: Classical and Bayesian Reliability Estimates

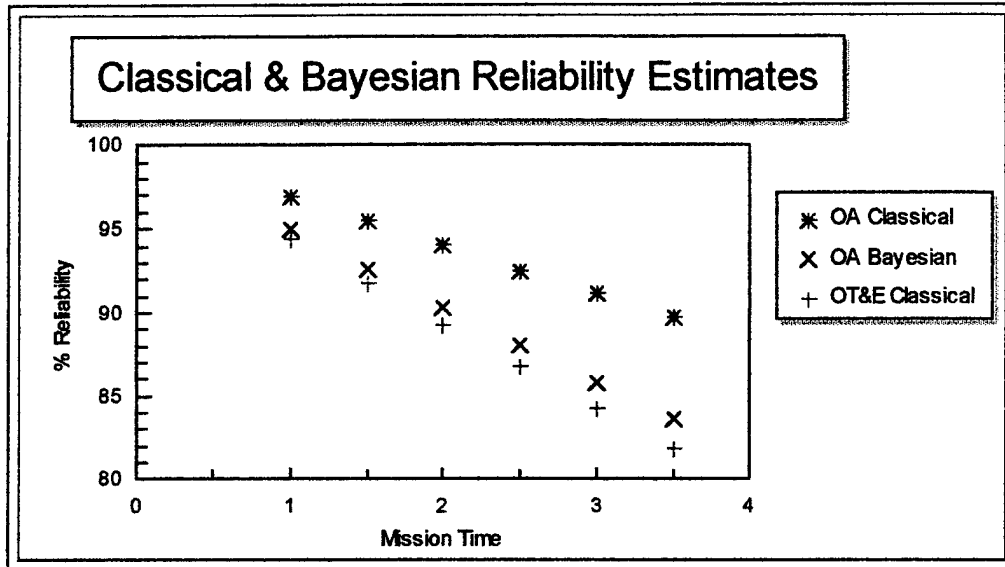

Figure 3: Comparison of OA Interval Widths

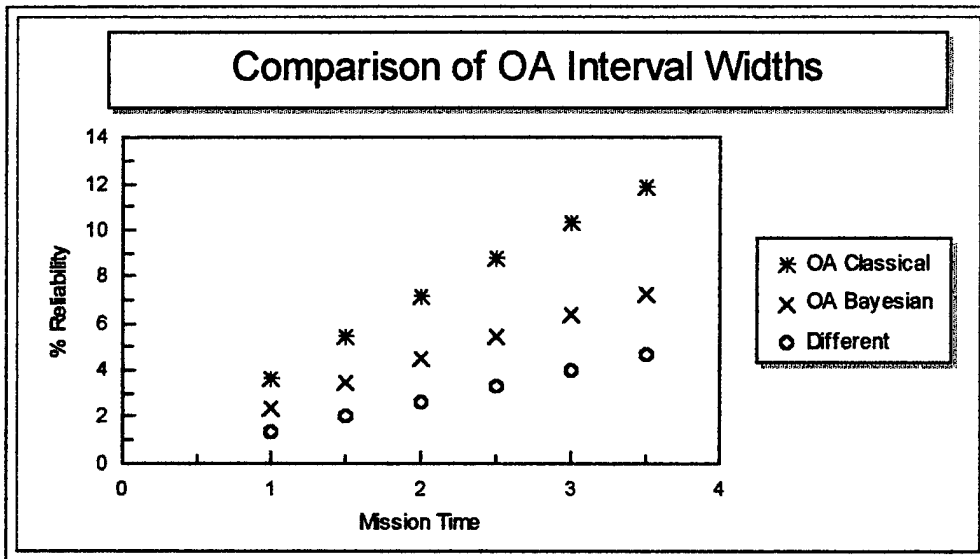

Figure 2 shows that the OA reliability estimates using the Bayesian method are lower (more conservative) than the OA classical estimates (which consider only the 4 failures in 129.4 hours) for the six different values of t .

Figure 3 shows that the strength of Bayesian analysis lies in the posterior analysis. In all six cases, the Bayesian method yields a tighter range for the point estimate. The difference between the OA Bayesian probability interval width and OA classical confidence interval width ranges from 1.34% to 4.66% for the mission times being considered. As the mission time increases, the widths of the confidence interval and the probability interval both increase and the gaps between the two intervals get larger.

Reliability Analysis of a Series System.

Consider a system composed of $k = 3$ independent components in series configuration. The time to failure of each component is assumed to be exponentially distributed. Let $\lambda_1 = 0.05$ failure per hour, $\lambda_2 = 0.067$ failure per hour, and $\lambda_3 = 0.05$ failure per hour be the respective constant failure rates of each component. The failure rate for the system is

$$\lambda = \sum_{i=1}^3 \lambda_i = 0.05 + 0.067 + 0.05 = \mathbf{0.167 \text{ failure per hour.}}$$

Thus the mean failure time for the system is

$$E(\lambda) = \left(\frac{1}{\lambda}\right) = \left(\frac{1}{0.167}\right) = \mathbf{6 \text{ hours.}}$$

For the true system, using a mission time, t of one hour, the reliability of components 1, 2, and 3 are

$$R_1 = R_3 = \exp(-0.05) = \mathbf{95.12\%}$$

$$R_2 = \exp(-0.067) = \mathbf{93.52\%}.$$

The reliability of the system can be calculated as

$$R_s = R_1 \times R_2 \times R_3 = 95.12\% \times 93.52\% \times 95.12\% = \mathbf{84.62\%}$$

$$\text{or } R_s = \exp(-\lambda t) = \exp(-0.167) = \mathbf{84.62\%}.$$

Using a computer program called RAPTOR (Rapid Availability Prototyping for Testing Operational Readiness), which is developed by AFOTEC, to simulate the true system, the following data are obtained (to review the simulated data, see Appendix C):

Table 6: System Level DT Data

Run i	T _i Hours	X _i Failures
1	499.86	80
2	449.53	78
3	384.76	46
4	543.47	97
5	591.88	75

Table 7: System Level OT Data

Run i	T _i Hours	X _i Failures
1	87.86	13
2	122.92	27

Table 8: Component Level DT Data

Run i	T _i Hours	X _i Failures Component 1	X _i Failures Component 2	X _i Failures Component 3
1	499.86	24	28	28
2	449.53	20	37	21
3	384.76	13	20	13
4	543.47	29	39	29
5	591.88	21	33	21

Table 9: Component Level OT Data

Run i	T _i Hours	X _i Failures Component 1	X _i Failures Component 2	X _i Failures Component 3
1	87.86	4	5	4
2	122.92	9	10	8

The reliability of the system for a mission time t will be estimated and 80% confidence intervals associated with the estimated system reliability will be computed using the methodology given in Chapter III. From the data above, the following results are obtained (for detailed calculation, see Appendix D):

Table 10: System Reliability Using System Level Data

	Classical Method	Bayesian Method 1	Bayesian Method
DT&E R(1) 80% CI/PI Width	85.88% (85.01%,86.74%) 1.73%		
OT&E R(1) 80% CI/PI Width	82.72% (79.53%,85.86%) 6.33%	81.62% (85.53%)	84.31% (82.10%,86.46%) 4.36%
DT&E R(1.5) 80% CI/PI Width	79.58% (78.38%,80.78%) 2.40%		
OT&E R(1.5) 80% CI/PI Width	75.23% (70.92%,79.56%) 6.33%	73.77% (79.11%)	77.43% (74.40%,80.39%) 5.99%
DT&E R(2) 80% CI/PI Width	73.75% (72.27%,75.23%) 2.96%		
OT&E R(2) 80% CI/PI Width	68.42% (63.24%,73.72%) 10.48%	66.69% (73.16%)	71.11% (67.41%,74.75%) 7.34%
DT&E R(2.5) 80% CI/PI Width	68.34% (66.63%,70.07%) 3.44%		
OT&E R(2.5) 80% CI/PI Width	62.22% (56.40%,68.30%) 11.90%	60.30% (67.67%)	65.32% (61.08%,69.51%) 8.43%
DT&E R(3) 80% CI/PI Width	63.33% (61.43%,65.26%) 3.83%		
OT&E R(3) 80% CI/PI Width	56.59% (50.29%,63.29%) 13%	54.54% (62.59%)	60.01% (55.35%,64.63%) 9.28%

* The Value in () in Bayesian1 column is combined DT & OT.

Table 11: System Reliability Using Component Level Data

	Classical Method	Bayesian Method	True R
DT&E R(1) 80% CI/PI Width	85.88% (84.37%,87.35%) 2.98%		84.62%
OT&E R(1) 80% CI/PI Width	82.72% (77.21%,88.07%) 10.86%	84.98% (82.15%,87.94%) 5.79%	84.62%
DT&E R(1.5) 80% CI/PI Width	79.58% (77.51%,81.64%) 4.13%		77.84%
OT&E R(1.5) 80% CI/PI Width	75.23% (67.85%,82.65%) 14.8%	78.35% (74.47%,82.47%) 8%	77.84%
DT&E R(2) 80% CI/PI Width	73.75% (71.21%,76.31%) 5.1%		71.61%
OT&E R(2) 80% CI/PI Width	68.42% (59.63%,77.56%) 17.93%	72.24% (67.50%,77.35%) 9.85%	71.61%
DT&E R(2.5) 80% CI/PI Width	68.34% (65.40%,71.32%) 5.92%		65.87%
OT&E R(2.5) 80% CI/PI Width	62.22% (52.39%,72.79%) 20.4%	66.61% (61.17%,72.54%) 11.37%	65.87%
DT&E R(3) 80% CI/PI Width	63.34% (60.08%,66.66%) 6.58%		60.59%
OT&E R(3) 80% CI/PI Width	56.60% (46.03%,68.31%) 22.28%	61.42% (55.45%,68.02%) 12.57%	60.59%

Figure 4: OT&E Reliability using Bayesian Method 1

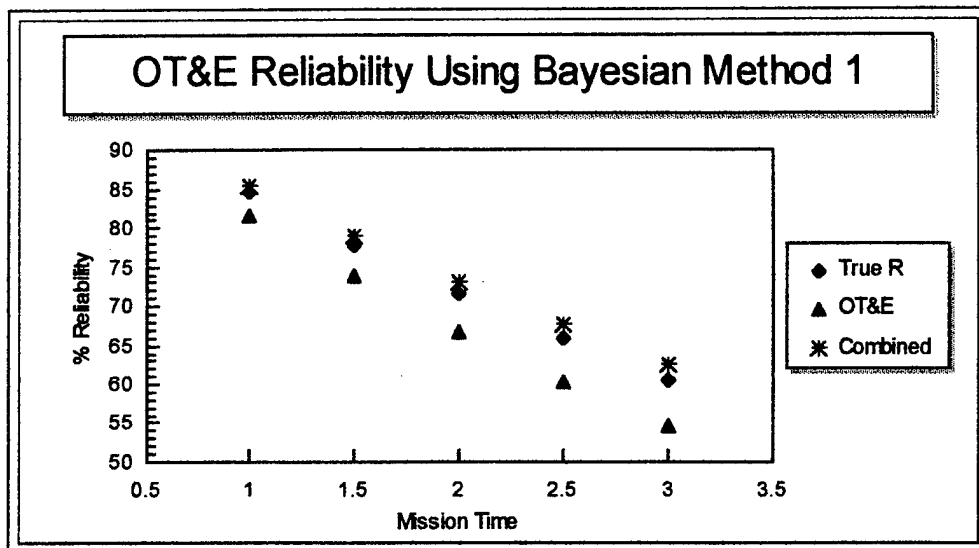

Figure 4 shows that using Bayesian method 1 (Bayesian method 1 only gives a reliability estimate), the reliability estimates using only OT&E data are lower than the true reliability. The gaps between the true reliability and the OT&E reliability estimates for the mission times being considered range from 3.01% to 6.01%. Since the true reliability of the system is known, you would want the reliability estimates of the system to be as close to the true reliability as possible. The results obtained above using only OT&E data are not very good.

The reliability estimates using combined OT&E and DT&E data are higher than the true reliability. The gaps between the true reliability and the reliability estimates for the mission times being considered range from 0.91% to 2%. The deviations from the true reliability are still significant.

However, the results are much better than just using OT&E data. The rest of the the results below used the methodology for the exponential model given in Chapter III.

Figure 5: Classical & Bayesian Reliability Estimates

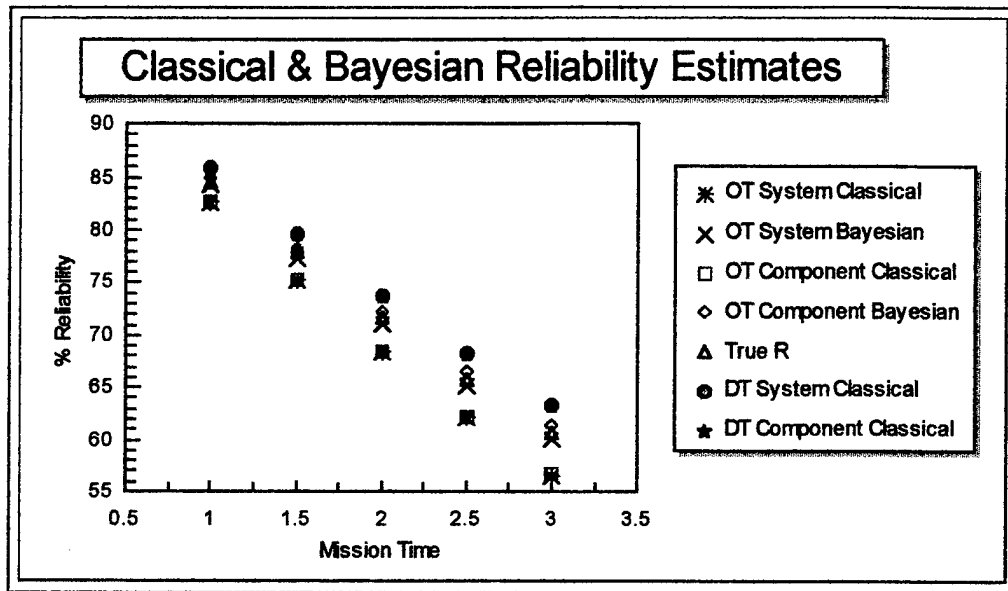

Figure 5 shows that the DT&E classical reliability estimates are higher than the true reliability. The deviations range from 1.26% to 2.74% for the mission times being considered. The deviations are considered to be significant. The OT&E reliability estimates using the Bayesian method are higher than the OT&E classical estimates and closer to the true reliability for the five different values of t at both the system level and component level. The OT&E reliability estimates using the classical method are lower than the true reliability. The deviations range

from 1.9% to 4% for the mission times being considered. Again, the deviations are considered to be significant.

The OT&E reliability estimates using the Bayesian method are all very close (less than 1%) to the true reliability. The OT&E reliability estimates using system level data underestimated the true reliability with deviations ranging from 0.31% to 0.58% for the mission times being considered. Using component level data, the OT&E reliability estimates overestimated the true reliability with deviations ranging from 0.36% to 0.83% for the mission times being considered.

Figure 6: Comparison of OT&E Interval Widths (System Level)

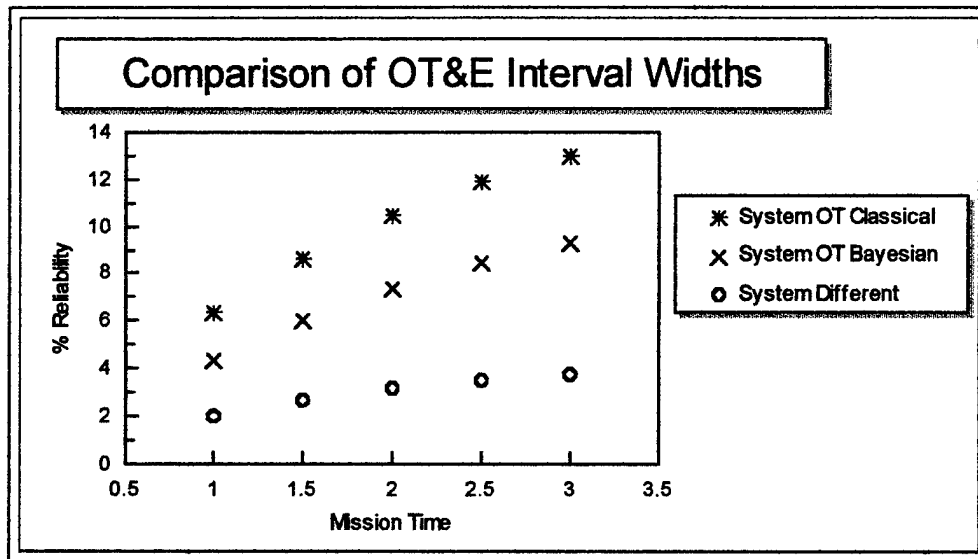
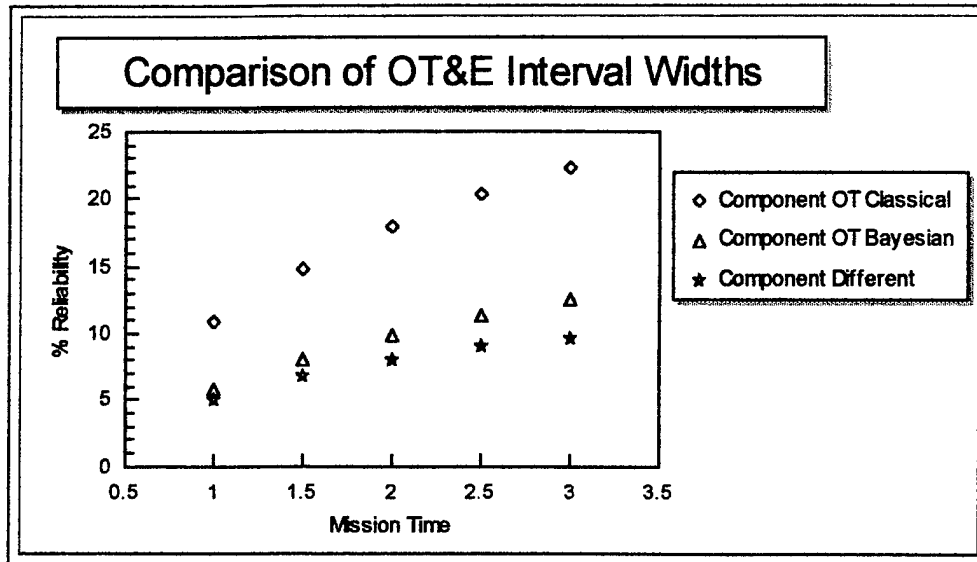

Figure 7: Comparison of OT&E Interval Widths
(Component Level)



Figures 6 and 7 show the strength of Bayesian analysis lies in the posterior analysis. In all five cases, the Bayesian method yields much tighter ranges for the point estimate at both the system and component level. At the system level, the difference between the OT&E Bayesian probability interval width and OT&E classical confidence interval width ranges from 1.97% to 3.72% for the mission times being considered. At the component level, the difference ranges from 5.07% to 9.71%. System level reliability estimates yield tighter intervals than component level aggregated to system. For the mission times being considered, the difference ranges from 4.53% to 9.28% for OT&E classical confidence interval widths and from 1.43% to 3.29% for OT&E Bayesian probability interval widths.

Reliability Analysis of a Parallel System with Independent and Identical Components.

Consider a system composed of 3 independent and identical components arranged in a parallel configuration. The time to failure of each component is assumed to be exponentially distributed. Let $\lambda = 0.05$ failure per hour be the constant failure rate of each component. For the true system, using a mission time, t of one hour, the reliability of components 1, 2, and 3 are

$$R_c = R_1 = R_2 = R_3 = \exp(-0.05) = \mathbf{95.1229\%}.$$

The reliability of the system can be calculated as

$$R_s = 1 - (1 - R_c)^3 = 1 - (1 - 95.12\%)^3 = \mathbf{99.9884\%}.$$

Using a computer program called RAPTOR, which is developed by AFOTEC, to simulate the true system, the following data are obtained (to review the simulated data, see Appendix E):

Table 12: Aggregated Component Level DT Data

Run i	T_i Hours	X_i Failures
1	1,493.82	79
2	1,463.13	75
3	1,492.59	66
4	1,490.85	70
5	1,490.58	81

Table 13: Aggregated Component Level OT Data

Run i	T_i Hours	X_i Failures
1	373.26	22
2	346.62	15

Table 14: Component Level DT Data

Run i	T _i Hours	X _i Failures Component 1	X _i Failures Component 2	X _i Failures Component 3
1	497.94	24	35	20
2	487.71	26	30	19
3	497.53	22	21	23
4	496.95	20	19	31
5	496.86	23	28	30

Table 15: Component Level OT Data

Run i	T _i Hours	X _i Failures Component 1	X _i Failures Component 2	X _i Failures Component 3
1	124.42	7	8	7
2	115.54	3	6	6

The reliability of the system for a mission time t will be estimated and 80% confidence intervals associated with the estimated system reliability will be computed using the methodology given in Chapter III. From the data above, the following results are obtained (for detailed calculation, see Appendix F):

Table 16: System Reliability Using Aggregated Data

	Classical Method	Bayesian Method	True R
DT R(1) 80% CI/PI Width	99.989% (99.986%,99.991%) 0.005%		99.988%
OT R(1) 80% CI/PI Width	99.987% (99.978%,99.994%) 0.016%	99.988% (99.985%,99.991%) 0.006%	99.988%
DT R(5) 80% CI/PI Width	98.922% (98.720%,99.100%) 0.38%		98.918%
OT R(5) 80% CI/PI Width	98.837% (98.069%,99.367%) 1.298%	98.906% (98.604%,99.161%) 0.557%	98.918%
DT R(10) 80% CI/PI Width	93.930% (92.956%,94.823%) 1.867%		93.910%
OT R(10) 80% CI/PI Width	93.508% (89.972%,96.217%) 6.245%	93.865% (92.394%,95.133%) 2.739%	93.910%
DT R(15) 80% CI/PI Width	85.355% (83.335%,87.259%) 3.924%		85.314%
OT R(15) 80% CI/PI Width	84.480% (77.491%,90.355%) 12.864%	85.238% (82.202%,87.937%) 5.735%	85.314%

Table 17: System Reliability Using Component Level Data

	Classical Method	Bayesian Method	True R
DT R(1) 80% CI/PI Width	99.989% (99.984%, 99.992%) 0.008%		99.988%
OT R(1) 80% CI/PI Width	99.988% (99.969%, 99.997%) 0.028%	99.988% (99.980%, 99.994%) 0.014%	99.988%
DT R(5) 80% CI/PI Width	98.927% (98.567%, 99.222%) 0.655%		98.918%
OT R(5) 80% CI/PI Width	98.871% (97.412%, 99.641%) 2.229%	98.880% (98.225%, 99.369%) 1.144%	98.918%
DT R(10) 80% CI/PI Width	93.962% (92.228%, 95.452%) 3.224%		93.910%
OT R(10) 80% CI/PI Width	93.699% (87.227%, 97.748%) 10.521%	93.772% (90.690%, 96.225%) 5.535%	93.910%
DT R(15) 80% CI/PI Width	85.429% (81.881%, 88.644%) 6.763%		85.314%
OT R(15) 80% CI/PI Width	84.920% (72.587%, 93.991%) 21.404%	85.129% (78.908%, 90.377%) 11.469%	85.314%

Figure 8: Classical and Bayesian Reliability Estimates

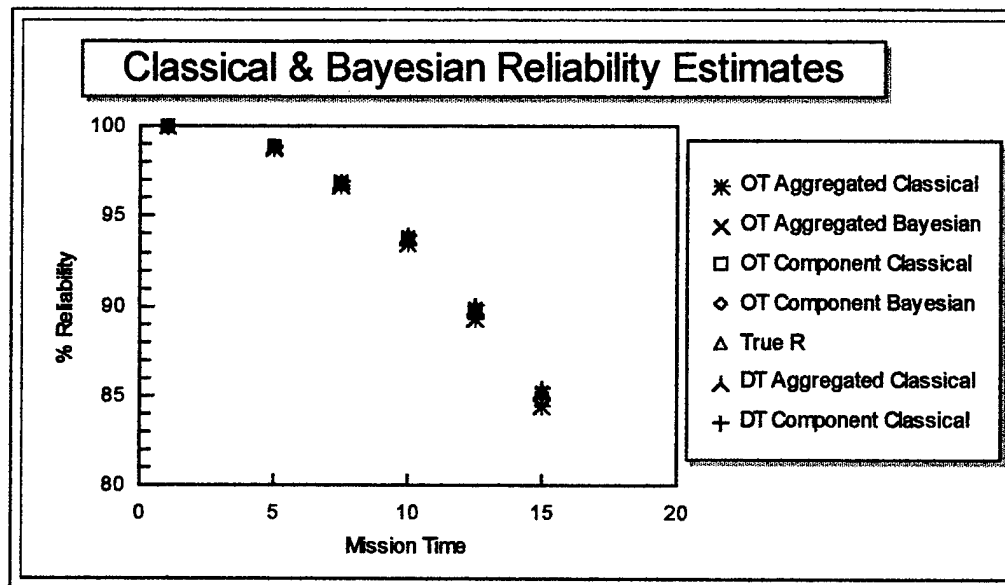

Figure 8 shows that the DT&E classical reliability estimates slightly overestimate the true reliability. The deviations range from 0.001% to 0.12% for the mission times being considered. The deviations are considered to be insignificant. The OT&E reliability estimates using the classical method underestimated the true reliability. The deviations range from 0% to 0.83% for the mission times being considered. The deviations are considered to be not too bad.

The OT&E reliability estimates using the Bayesian method are all very close (less than 0.2%) to the true reliability. The OT&E reliability estimates using aggregated component level data underestimated the true reliability with deviations ranging from 0% to 0.08% for the mission times being considered. Using component level data, the OT&E reliability estimates also underestimated the true reliability with deviations ranging from 0% to 0.19% for the mission times being considered. The OT&E reliability estimates using the Bayesian method are closer to the true reliability than the classical OT&E reliability estimates.

Figure 9: Comparison of OT&E Interval Widths (Aggregated Level)

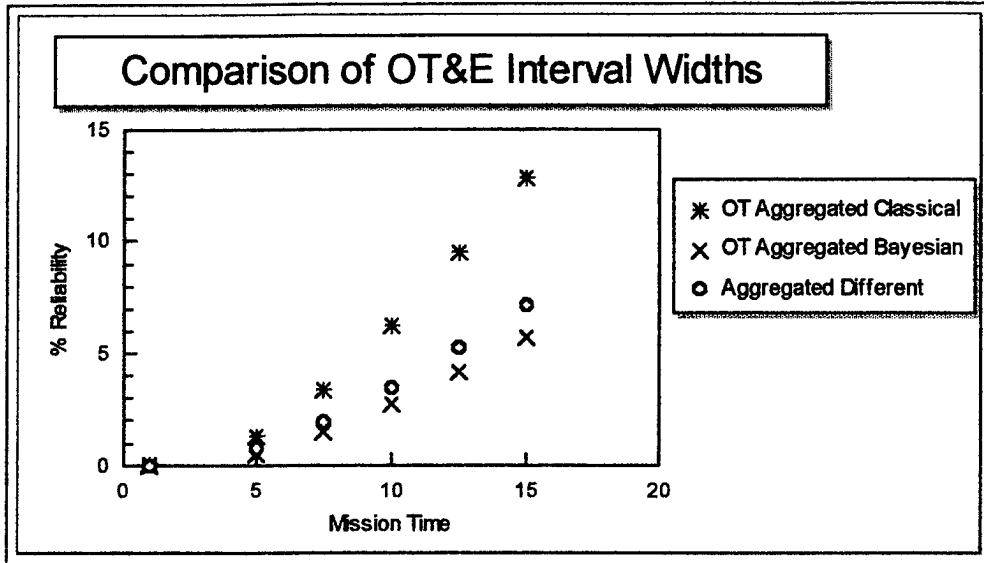
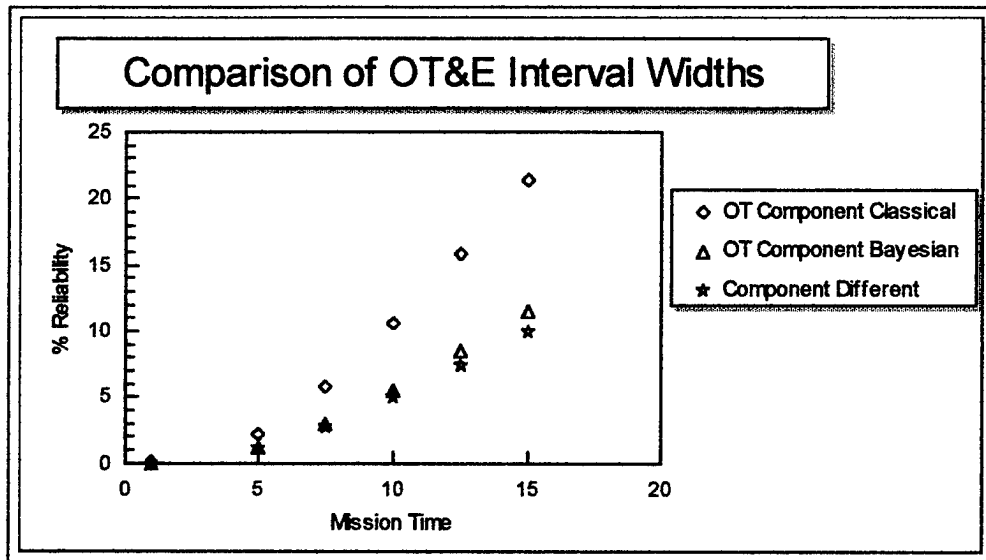

Figure 10: Comparison of OT&E Interval Widths (Component Level)



Figures 9 and 10 again show the strength of Bayesian analysis. In all six cases, the Bayesian method yields much tighter ranges for the point estimate at both the aggregated level and component level. At the aggregated component level, the difference between the OT&E Bayesian probability interval width and OT&E classical confidence interval width ranges from 0.01% to 7.13% for the mission times being considered. At the component level, the difference ranges from 0.01% to 9.94%. Aggregated component level reliability estimates yield tighter intervals than component levels aggregated to system. For the mission times being considered, the difference ranges from 0.01% to 8.54% for OT&E classical confidence interval widths and from 0.01% to 5.73% for OT&E Bayesian probability interval widths.

Reliability Analysis of a Parallel System with Different Independent Components.

Consider a system composed of 3 different independent components arranged in a parallel configuration. The time to failure of each component is assumed to be exponentially distributed. Let $\lambda_1 = 0.1$ failure per hour, $\lambda_2 = 0.05$ failure per hour, and $\lambda_3 = 0.025$ failure per hour be the respective constant failure rates of each component.

For the true system, using a mission time, t of one hour, the reliability of components 1, 2, and 3 are

$$R_1 = \exp(-0.100) = \mathbf{90.48\%}$$

$$R_2 = \exp(-0.050) = \mathbf{95.12\%}$$

$$R_3 = \exp(-0.025) = \mathbf{97.53\%}$$

The reliability of the system can be calculated as

$$R_s = 1 - (1 - R_1)(1 - R_2)(1 - R_3)$$

$$= 1 - (1 - 0.9048)(1 - 0.9512)(1 - 0.9753) = \mathbf{99.9885\%}$$

Using a computer program called RAPTOR, which is developed by AFOTEC, to simulate the true system, the following data are obtained (to review the simulated data, see Appendix G):

Table 18: Component Level DT Data

Run i	T _i Hours	X _i Failures Component 1	X _i Failures Component 2	X _i Failures Component 3
1	488.03	55	27	10
2	498.15	53	30	8
3	498.39	44	24	12
4	496.55	36	26	9
5	496.36	60	33	9

Table 19: Component Level OT Data

Run i	T _i Hours	X _i Failures Component 1	X _i Failures Component 2	X _i Failures Component 3
1	122.22	13	9	3
2	113.29	8	8	4

The reliability of the system for a mission time t will be estimated and 80% confidence intervals associated with the estimated system reliability will be computed using the methodology given in Chapter III. From the data above, the following results are obtained (for detailed calculation, see Appendix H):

Table 20: System Reliability Using Component Level Data

	Classical Method	Bayesian Method	True R
DT R(1) 80% CI/PI Width	99.99% (99.986%, 99.993%) 0.007%		99.989%
OT R(1) 80% CI/PI Width	99.983% (99.957%, 99.995%) 0.038%	99.989% (99.983%, 99.994%) 0.011%	99.989%
DT R(5) 80% CI/PI Width	99.106% (98.776%, 99.371%) 0.595%		98.977%
OT R(5) 80% CI/PI Width	98.495% (96.682%, 99.503%) 2.821%	99.062% (98.584%, 99.428%) 0.844%	98.977%
DT R(10) 80% CI/PI Width	95.189% (93.661%, 96.496%) 2.835%		94.498%
OT R(10) 80% CI/PI Width	92.202% (84.868%, 97.087%) 12.219%	94.974% (92.813%, 96.722%) 3.909%	94.498%
DT R(15) 80% CI/PI Width	88.792% (85.7%, 91.578%) 5.878%		87.183%
OT R(15) 80% CI/PI Width	82.457% (69.464%, 92.678%) 23.214%	88.323% (84.066%, 91.935%) 7.869%	87.183%

Figure 11 shows that the DT&E classical reliability estimates overestimated the true reliability. The deviations range from 0.001% to 1.61% for the mission times being considered. The deviations are considered to be significant. The OT&E reliability estimates using the classical method underestimated the true reliability. The deviations range from 0.006% to 5.87% for the mission times being considered. The deviations are again considered to be significant.

Using component level data, the OT&E reliability estimates overestimated the true reliability with deviations ranging from 0% to 1.14% for the mission times being considered. While the deviations are still large, the OT&E reliability estimates using the Bayesian method are much closer to the true reliability than the classical OT&E reliability estimates.

Figure 11: Classical and Bayesian Reliability Estimates

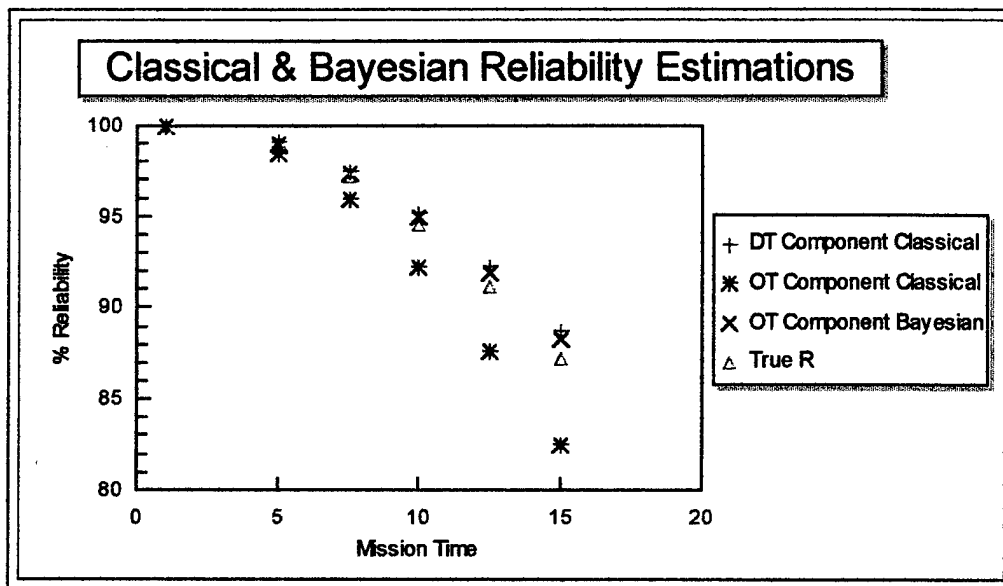
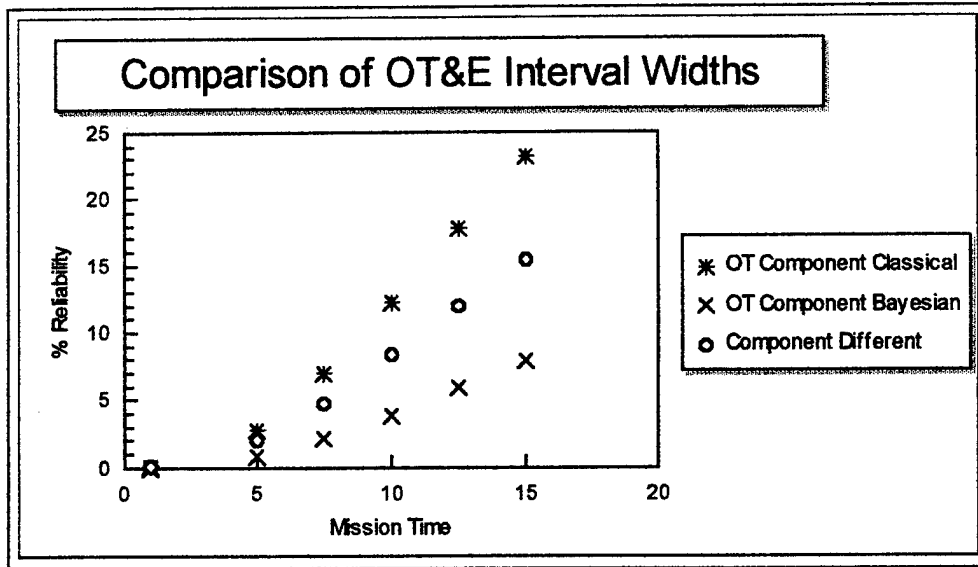

Figure 12 once again shows the strength of Bayesian analysis. In all six cases, the Bayesian method yields much tighter ranges for the point estimate. The difference between the OT&E Bayesian probability interval width and OT&E classical confidence interval width ranges from 0.03% to 15.35% for the mission times being considered.

Figure 12: Comparison of OT&E Interval Widths



Reliability Analysis of a Bridge System with Independent and Identical Components.

Consider a system composed of 5 independent and identical components given in Figure 1 (page 30). The time to failure of each component is assumed to be exponentially distributed. Let $\lambda = 0.05$ failure per hour be the constant failure rate of each component. For the true system, using a mission time, t of one hour, the reliability of components 1, 2, 3, 4, and 5 are

$$R_c = R_1 = R_2 = R_3 = R_4 = R_5 = \exp(-0.05) = \mathbf{95.12\%}.$$

The reliability of the system can be calculated as

$$R_s = R_1R_4 + R_2R_5 + R_1R_3R_5 + R_2R_3R_4 - R_1R_2R_3R_4 - R_1R_2R_3R_5 - R_1R_2R_4R_5 - R_1R_3R_4R_5 - R_2R_3R_4R_5 + 2R_1R_2R_3R_4R_5 = \mathbf{99.50\%}.$$

Using a computer program called RAPTOR to simulate the true system, the following data are obtained (to review the simulated data, see Appendix I):

Table 21: Aggregated Component Level DT Data

Run i	T _i Hours	X _i Failures
1	2,496.85	136
2	2,486.35	123
3	2461.30	124
4	2493.05	125
5	2498.40	130

Table 22: Aggregated Component Level OT Data

Run i	T _i Hours	X _i Failures
1	618.85	30
2	604.10	26

Table 23: Component Level DT Data

Run i	T _i Hours	C1 X _i	C2 X _i	C3 X _i	C4 X _i	C5 X _i
1	499.37	32	21	35	25	23
2	497.27	28	17	24	27	27
3	492.26	27	28	25	20	24
4	498.61	26	27	22	23	27
5	499.68	27	23	33	25	22

Table 24: Component Level OT Data

Run i	T _i Hours	C1 X _i	C2 X _i	C3 X _i	C4 X _i	C5 X _i
1	123.77	7	6	8	3	6
2	120.82	6	5	6	4	5

The reliability of the system for a mission time t will be estimated and 80% confidence intervals associated with the estimated system reliability will be computed using the methodology given in Chapter III. From the data above, the following results are obtained (for detailed calculation, see Appendix J):

Table 25: System Reliability Using Aggregated Data

	Classical Method	Bayesian Method	True R
DT R(1) 80% CI/PI Width	99.48% (99.42%, 99.53%) 0.11%		99.50%
OT R(1) 80% CI/PI Width	99.58% (99.43%, 99.71%) 0.28%	99.49% (99.44%, 99.54%) 0.1%	99.50%
DT R(4) 80% CI/PI Width	92.39% (91.67%, 93.07%) 1.4%		92.74%
OT R(4) 80% CI/PI Width	93.82% (91.70%, 95.62%) 3.92%	92.52% (91.85%, 93.16%) 1.31%	92.74%
DT R(7) 80% CI/PI Width	79.95% (78.29%, 81.55%) 3.26%		80.76%
OT R(7) 80% CI/PI Width	83.36% (78.37%, 87.80%) 9.43%	80.25% (78.70%, 81.75%) 3.05%	80.76%
DT R(10) 80% CI/PI Width	65.75% (63.35%, 68.13%) 4.78%		66.95%
OT R(10) 80% CI/PI Width	70.86% (63.47%, 77.91%) 14.44%	66.21% (63.94%, 68.43%) 4.49%	66.95%

Table 26: System Reliability Using Component Level Data

	Classical Method	Bayesian Method	True R
DT R(1) 80% CI/PI Width	99.50% (99.38%, 99.61%) 0.23%		99.50%
OT R(1) 80% CI/PI Width	99.63% (99.24%, 99.85%) 0.61%	99.52% (99.38%, 99.65%) 0.27%	99.50%
DT R(4) 80% CI/PI Width	92.64% (91.01%, 94.10%) 3.09%		92.74%
OT R(4) 80% CI/PI Width	94% (89.18%, 97.66%) 8.48%	92.87% (90.91%, 94.67%) 3.76%	92.74%
DT R(7) 80% CI/PI Width	80.48% (76.76%, 83.98%) 7.22%		80.76%
OT R(7) 80% CI/PI Width	84.65% (72.73%, 93.18%) 20.45%	81.05% (76.50%, 85.40%) 8.90%	80.76%
DT R(10) 80% CI/PI Width	66.52% (61.16%, 71.79%) 10.63%		66.95%
OT R(10) 80% CI/PI Width	72.81% (55.66%, 87.02%) 31.36%	67.39% (60.78%, 74.03%) 13.25%	66.95%

Figure 13: Classical and Bayesian Reliability Estimates

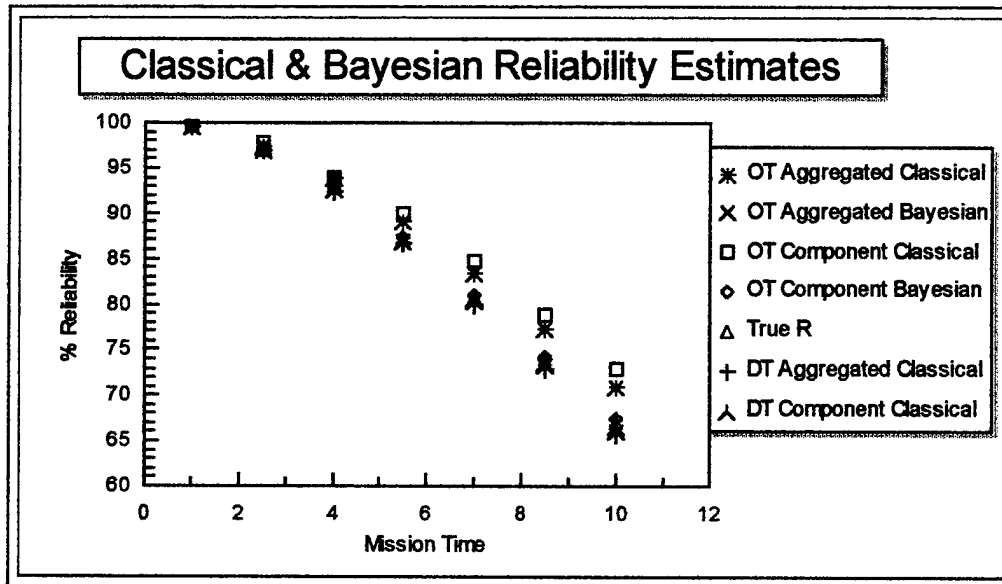

Figure 13 shows that the DT&E classical reliability estimates underestimated the true reliability. The deviations range from 0.02% to 1.2% for the mission times being considered. The deviations are considered to be significant. The OT&E reliability estimates using the classical method overestimated the true reliability. The deviations range from 0.08% to 5.86% for the mission times being considered. The deviations are again considered to be significant.

The OT&E reliability estimates using the Bayesian method are all very close (less than 1%) to the true reliability. The OT&E reliability estimates using aggregated component level data underestimated the true reliability with deviations ranging from 0.01% to 0.74% for the mission times being considered. Using component level data, the OT&E reliability estimates overestimated the true reliability with deviations ranging from 0.02% to 0.44% for the mission times being considered. While the deviations are still significant, the OT&E reliability estimates using the Bayesian method are much closer to the true reliability than the classical OT&E reliability estimates.

Figure 14: Comparison of OT&E Interval Widths (Aggregated Level)

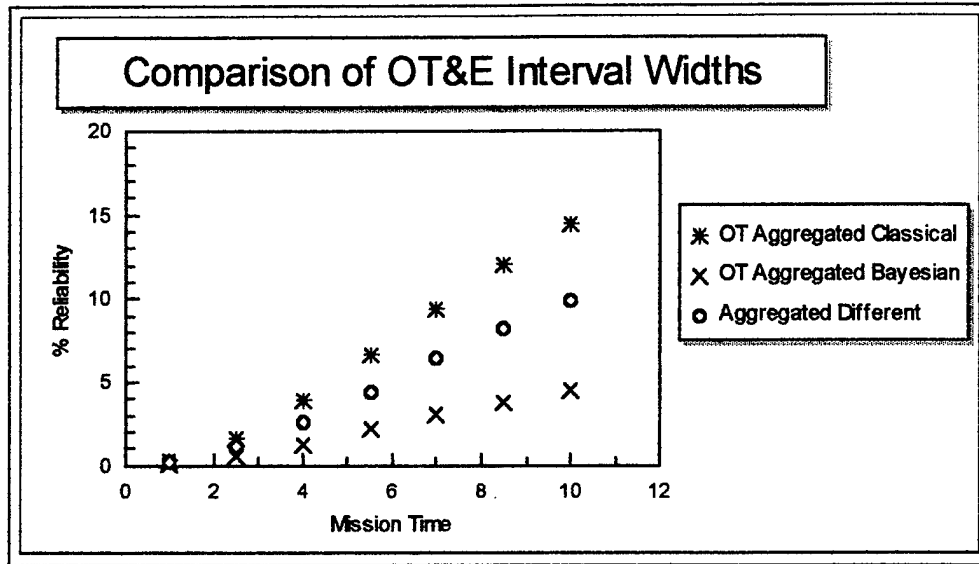
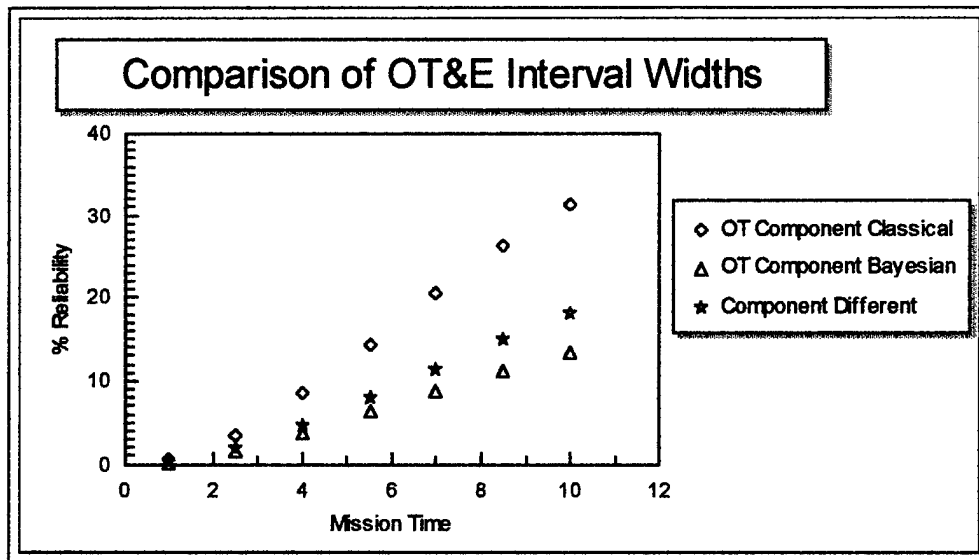

Figure 15: Comparison of OT&E Interval Widths (Component Level)



Figures 14 and 15 again show the strength of Bayesian analysis. In all seven cases, the Bayesian method yields much tighter ranges for the point estimate at both the aggregated level and component level. At the aggregated component level, the difference between the OT&E Bayesian probability interval width and OT&E classical confidence interval width ranges from 0.18% to 9.95% for the mission times being considered. At the component level, the difference ranges from 0.34% to 18.11%. Aggregated component level reliability estimates yield tighter intervals than component level aggregated to system. For the mission times being considered, the difference ranges from 0.33% to 16.92% for OT&E classical confidence interval widths and from 0.17% to 8.76% for OT&E Bayesian probability interval widths.

Reliability Analysis of a Bridge System with Different Independent Components.

Consider a system composed of 5 independent components given in Figure 1 (page 30). The time to failure of each component is assumed to be exponentially distributed. Let $\lambda_1 = 0.1$ failure per hour, $\lambda_2 = 0.05$ failure per hour, $\lambda_3 = 0.033$ failure per hour, $\lambda_4 = 0.025$ failure per hour, and $\lambda_5 = 0.02$ failure per hour be the respective constant failure rates of each component.

For the true system, using a mission time, t of one hour, the reliability of components 1, 2, 3, 4, and 5 are

$$R_1 = \exp(-0.10) = \mathbf{90.48\%}$$

$$R_2 = \exp(-0.05) = \mathbf{95.12\%}$$

$$R_3 = \exp(-0.033) = \mathbf{96.75\%}$$

$$R_4 = \exp(-0.025) = \mathbf{97.53\%}$$

$$R_5 = \exp(-0.20) = \mathbf{98.02\%}.$$

The reliability of the system can be calculated as

$$R_s = R_1R_4 + R_2R_5 + R_1R_3R_5 + R_2R_3R_4 - R_1R_2R_3R_4 - R_1R_2R_3R_5 - R_1R_2R_4R_5 - R_1R_3R_4R_5 - R_2R_3R_4R_5 + 2R_1R_2R_3R_4R_5 = \mathbf{99.48\%}.$$

Using a computer program called RAPTOR, which is developed by AFOTEC, to simulate the true system, the following data are obtained (to review the simulated data, see Appendix K):

Table 27: Component Level DT Data

Run i	T _i Hours	C1 X _i	C2 X _i	C3 X _i	C4 X _i	C5 X _i
1	499.09	51	19	22	15	13
2	490.55	41	23	21	12	9
3	497.97	44	30	17	6	8
4	495.31	52	26	18	12	10
5	498.76	48	25	22	18	15

Table 28: Component Level OT Data

Run i	T _i Hours	C1 X _i	C2 X _i	C3 X _i	C4 X _i	C5 X _i
1	124.09	11	10	5	1	1
2	119.96	12	3	3	4	1

The reliability of the system for a mission time t will be estimated and 80% confidence intervals associated with the estimated system reliability will be computed using the methodology given in Chapter III. From the data above, the following results are obtained (for detailed calculation, see Appendix L):

Table 29: System Reliability Using Component Level Data

	Classical Method	Bayesian Method	True R
DT R(1) 80% CI/PI Width	99.50% (99.38%, 99.59%) 0.21%		99.48%
OT R(1) 80% CI/PI Width	99.51% (99.14%, 99.76%) 0.62%	99.50% (99.33%, 99.65%) 0.32%	99.48%
DT R(4) 80% CI/PI Width	93.08% (91.64%, 94.37%) 2.73%		92.97%
OT R(4) 80% CI/PI Width	93.52% (89.08%, 96.70%) 7.62%	93.24% (91.06%, 95.12%) 4.06%	92.97%
DT R(7) 80% CI/PI Width	82.21% (78.92%, 85.27%) 6.35%		82.13%
OT R(7) 80% CI/PI Width	83.58% (73.88%, 91.23%) 17.35%	82.71% (77.73%, 87.16%) 9.43%	82.13%
DT R(10) 80% CI/PI Width	69.82% (64.97%, 74.52%) 9.55%		69.86%
OT R(10) 80% CI/PI Width	72.29% (58.41%, 84.44%) 26.03%	70.71% (63.34%, 77.61%) 14.27%	69.86%

Figure 16: Classical and Bayesian Reliability Estimates

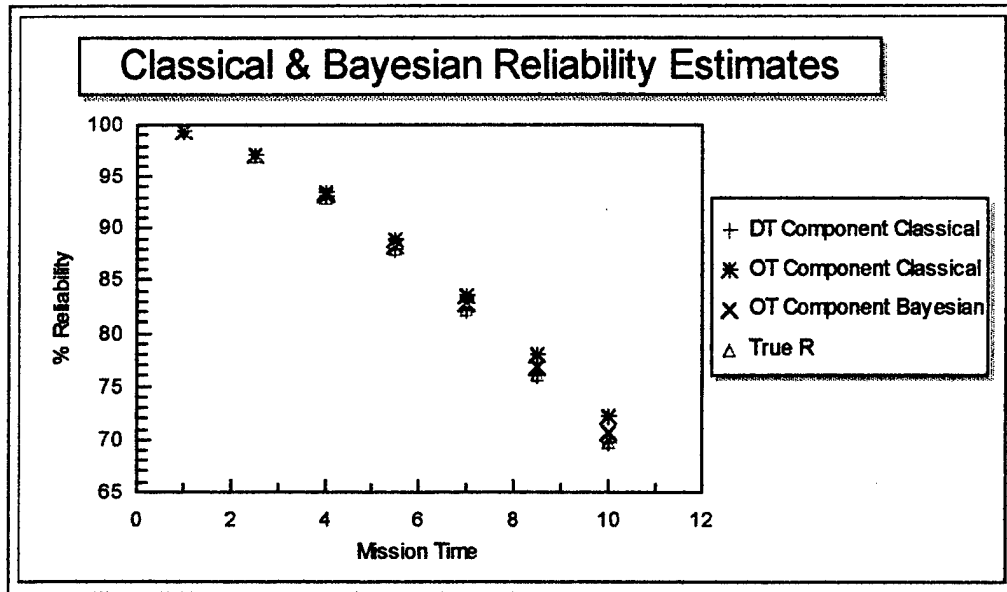

Figure 16 shows that the DT&E classical reliability estimates are very close to the true reliability. The deviations range from -0.04% to 0.11% for the mission times being considered. The deviations are considered to be insignificant. The OT&E reliability estimates using the classical method overestimated the true reliability. The deviations range from 0.03% to 2.43% for the mission times being considered. The deviations are considered to be significant.

Using component level data, the OT&E reliability estimates overestimated the true reliability with deviations ranging from 0.02% to 0.85% for the mission times being considered. While the deviations are still large, the OT&E reliability estimates using the Bayesian method are much

closer to the true reliability than the classical OT&E reliability estimates.

Figure 17: Comparison of OT&E Interval Widths

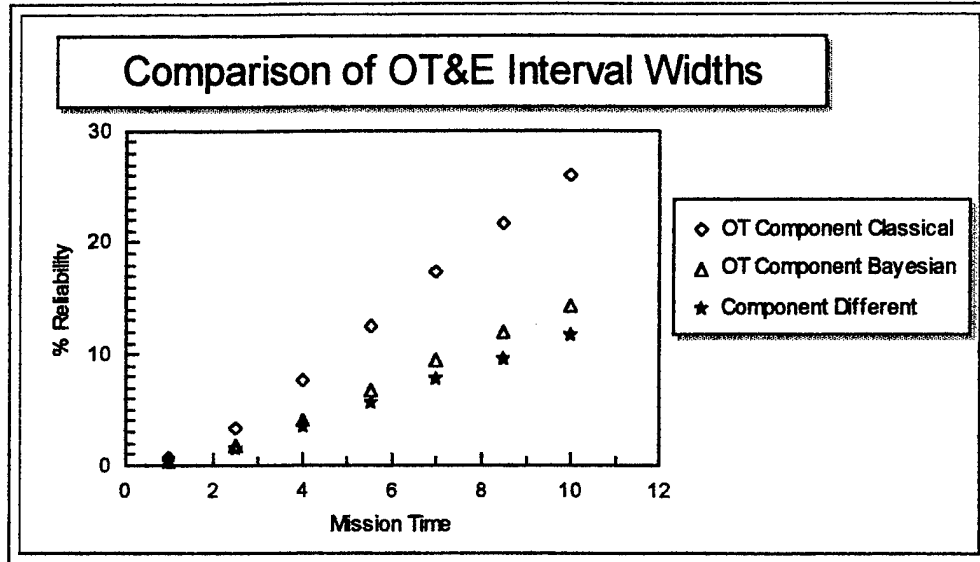

Figure 17 once again shows the strength of Bayesian analysis. In all seven cases, the Bayesian method yields much tighter ranges for the point estimate. The difference between the OT&E Bayesian probability interval width and OT&E classical confidence interval width ranges from 0.3% to 11.76% for the mission times being considered.

Summary.

The overall trend from the results obtained in this chapter is that the Bayesian methods used in this research produced much shorter confidence intervals compared to the classical methods. Another trend is that system level data and aggregated component level data yield tighter confidence intervals than component level data aggregated to system.

For the simulated systems considered in this research, the Bayesian reliability point estimates are much closer to the true reliability of the system as compared to the classical reliability estimates.

V. Conclusions

The results in Chapter IV show that the Bayesian methods used in this research produced much shorter confidence intervals about the reliability point estimates for a variety of systems than the traditional classical methods. This research shows that meaningful results (in the form of shorter confidence intervals) can be obtained by simply applying Bayesian techniques to consecutive test phases.

The binomial model shows that while the OT&E point estimates are similar (90.63% vs. 91.67%), the Bayesian method produced a much tighter confidence interval (12.66% vs. 27.88%), thus making it easier for managerial decision-making. The exponential model applied to a real set of data again shows that the Bayesian method produced smaller confidence intervals.

For a series system with exponential components, using simulated data for a 3-component system, the Bayesian method produced tighter confidence intervals. The reliability point estimates using the Bayesian method are closer to the true reliability of the system as compared to the classical reliability point estimates. System level reliability estimates yield much tighter confidence intervals than component level aggregated to system. From the results in

Chapter IV, note that the Bayesian Method 1 only produced the reliability point estimates. Thus this method might not be useful for a decision maker.

For a parallel system with independent and identical components, using simulated data for a 3-component system, the Bayesian method again produced tighter confidence intervals. The reliability point estimates using the Bayesian method are again closer to the true reliability of the system as compared to the classical reliability point estimates. Aggregated component level reliability estimates yield much tighter confidence intervals than component level estimates aggregated to system.

For a parallel system with different independent components, using simulated data for a 3-component system, the Bayesian method once again produced tighter confidence intervals. The reliability point estimates using the Bayesian method are again closer to the true reliability of the system as compared to the classical reliability point estimates.

For a bridge system given in Figure 1 (page 30) with independent and identical components, using simulated data, the Bayesian method again produced much tighter confidence intervals. The reliability point estimates using the Bayesian method are closer to the true reliability of the

system as compared to the classical reliability point estimates. Aggregated component level reliability estimates yield a much tighter confidence intervals than component level aggregated to system.

For a bridge system given in Figure 1 (page 30) with different independent components, using simulated data, the Bayesian method once again produced much tighter confidence intervals. The reliability point estimates using the Bayesian method are much closer to the true reliability of the system as compared to the classical reliability point estimates.

In summary, the results of this research show that the Bayesian method produced a much tighter confidence interval as compared to the classical method for OT&E data. System level data and aggregated component level data will yield a tighter confidence interval than component level data aggregated to system. For multiphase test process commonly implemented by agencies such as AFOTEC, the Bayesian method will work with using all the previous test data as prior information for the current test. However, it is up to the analysts to determine if the previous test data are representative of the current test. Otherwise, you are comparing apples to oranges and the results obtained are meaningless.

Appendix A: Calculation For The Binomial Model.

The Classical Binomial Method.

Suppose the following data are obtained from a missile program. For the DT&E portion of the test, two missiles failed out of 20 missiles launched. For the OT&E portion of the test, one missile failed out of 12 missiles launched. Assuming the data have the binomial distribution, point estimates for the probability of success p and 80% confidence interval about p will be computed. The point estimate of p for DT&E and OT&E are

$$\text{DT\&E: } \hat{p} = \left(\frac{18}{20} \right) = \mathbf{90.00\%}$$

$$\text{OT\&E: } \hat{p} = \left(\frac{11}{12} \right) = \mathbf{91.67\%}.$$

The 80% TCI are

$$\underline{\text{DT\&E: (75.52\%, 97.31\%)}}$$

$$\begin{aligned} \text{Lower bound: } & \left(\frac{18}{18 + (20 - 18 + 1)F_{1-0.2/2}(2 \times 20 - 2 \times 18 + 2, 2 \times 18)} \right) \\ & = \left(\frac{18}{18 + 3F_{0.9}(6, 36)} \right) = \left(\frac{18}{18 + 3 \times 1.95} \right) = \mathbf{0.7552} \end{aligned}$$

$$\begin{aligned} \text{Upper bound: } & \left(\frac{(18 + 1)F_{1-0.2/2}(2 \times 18 + 2, 2 \times 20 - 2 \times 18)}{(20 - 18) + (18 + 1)F_{1-0.2/2}(2 \times 18 + 2, 2 \times 20 - 2 \times 18)} \right) \\ & = \left(\frac{19F_{0.9}(38, 4)}{2 + 19F_{0.9}(38, 4)} \right) = \left(\frac{19 \times 3.81}{2 + 19 \times 3.81} \right) = \mathbf{0.9731} \end{aligned}$$

$$\underline{\text{OT\&E: (71.25\%, 99.13\%)}}$$

$$\begin{aligned} \text{Lower bound: } & \left(\frac{11}{11 + (12 - 11 + 1)F_{1-0.2/2}(2 \times 12 - 2 \times 11 + 2, 2 \times 11)} \right) \\ & = \left(\frac{11}{11 + 2F_{0.9}(4, 22)} \right) = \left(\frac{11}{11 + 2 \times 2.22} \right) = \mathbf{0.7125} \end{aligned}$$

$$\begin{aligned} \text{Upper bound: } & \left(\frac{(11+1)F_{1-0.2/2}(2 \times 11+2, 2 \times 12-2 \times 11)}{(12-11)+(11+1)F_{1-0.2/2}(2 \times 11+2, 2 \times 12-2 \times 11)} \right) \\ & = \left(\frac{12F_{0.9}(24, 2)}{1+12F_{0.9}(24, 2)} \right) = \left(\frac{12 \times 9.45}{1+12 \times 9.45} \right) = \mathbf{0.9913} \end{aligned}$$

The Bayesian Binomial Method.

There are two failures out of 20 missiles launched during DT&E, thus $x_0 = 18$ and $n_0 = 20$ and the $B(18, 20)$ prior distribution is used. There is one failure out of 12 missiles launched during OT&E, thus $x = 11$ and $n = 12$.

The mean of the posterior distribution is the Bayesian point estimator. Under the squared error loss function, the Bayesian point estimator is

$$\hat{p} = E(p|x; x_0, n_0) = \left(\frac{x+x_0}{n+n_0} \right) = \left(\frac{11+18}{12+20} \right) = \left(\frac{29}{32} \right) = \mathbf{90.63\%}.$$

For the 80% TBPI, the upper and lower interval endpoints are **(83.73%, 96.39%)**.

Lower bound:

$$\begin{aligned} & \left(\frac{11+18}{11+18+(12+20-11-18)F_{1-0.2/2}(2 \times 12+2 \times 20-2 \times 11-2 \times 18, 2 \times 11+2 \times 18)} \right) \\ & = \left(\frac{29}{29+3F_{0.9}(6, 58)} \right) = \left(\frac{29}{29+3 \times 1.88} \right) = \mathbf{0.8373} \end{aligned}$$

Upper bound:

$$\begin{aligned} & \left(\frac{(11+18)F_{1-0.2/2}(2 \times 11+2 \times 18, 2 \times 12+2 \times 20-2 \times 11-2 \times 18)}{12+20-11-18+(11+18)F_{1-0.2/2}(2 \times 11+2 \times 18, 2 \times 12+2 \times 20-2 \times 11-2 \times 18)} \right) \\ & = \left(\frac{29F_{0.9}(58, 6)}{3+29F_{0.9}(58, 6)} \right) = \left(\frac{29 \times 2.76}{3+29 \times 2.76} \right) = \mathbf{0.9639} \end{aligned}$$

Appendix B: Calculation For The Exponential Model.

The Classical Exponential Method.

The following data are obtained from a reliability test program.

Table B1: OT&E Data (3:6)

Terminal i	T _i Hours	X _i Failures	$\hat{\lambda}_i = X_i/T_i$
1	184.3	12	0.06511
2	232.6	9	0.03869
3	172.8	9	0.05208
4	284.4	17	0.05977
5	264.8	18	0.06798

Table B2: OA Data (3:7)

Terminal i	T _i Hours	X _i Failures
1	68.5	2
2	60.9	2

Assuming the time to failure of the terminals have the exponential distribution, point estimates for the failure rate λ and 80% confidence interval about λ will be computed.

$$\text{OT\&E: } \hat{\lambda} = \left(\frac{f_1}{T_1} \right) = \left(\frac{65}{1138.9} \right) = \mathbf{0.05707}$$

$$\text{OA: } \hat{\lambda} = \left(\frac{f_2}{T_2} \right) = \left(\frac{4}{129.4} \right) = \mathbf{0.03091}$$

where $f_1 = 65$ is the number of failures and $T_1 = 1138.9$ is the total test time from Table B1 and $f_2 = 4$ is the number of failures and $T_2 = 129.4$ is the total test time from Table B2.

The 80% two-sided confidence intervals (TCI) are

$$\text{OT\&E: } \left(\frac{\chi_{0.2/2}^2(2 \times 65)}{2 \times 1138.9}, \frac{\chi_{1-0.2/2}^2(2 \times 65)}{2 \times 1138.9} \right) = \left(\frac{\chi_{0.1}^2(130)}{2277.8}, \frac{\chi_{0.9}^2(130)}{2277.8} \right)$$

$$= \left(\frac{109.81}{2277.8}, \frac{151.05}{2277.8} \right) = (0.04821, 0.06631)$$

$$\underline{OA}: \left(\frac{\chi_{0.2/2}^2(2 \times 4)}{2 \times 129.4}, \frac{\chi_{1-0.2/2}^2(2 \times 4)}{2 \times 129.4} \right) = \left(\frac{\chi_{0.1}^2(8)}{258.8}, \frac{\chi_{0.9}^2(8)}{258.8} \right)$$

$$= \left(\frac{3.49}{258.8}, \frac{13.36}{258.8} \right) = (0.01349, 0.05163)$$

The reliability estimators of $R(t)$ for a mission time $t = 1$ hour are

$$\underline{OT\&E}: \hat{R}(t) = 94.45\%$$

$$\hat{R}(t) = \exp(-\hat{\lambda}t) = \exp(-0.05707 \times 1) = 0.9445$$

$$\underline{OA}: \hat{R}(t) = 96.96\%$$

$$\hat{R}(t) = \exp(-\hat{\lambda}t) = \exp(-0.03091 \times 1) = 0.9696.$$

The 80% two-sided confidence intervals (TCI) are

$$\underline{OT\&E}: (93.58\%, 95.29\%)$$

$$\exp(-0.06631 \times 1) \leq \hat{R}(1) \leq \exp(-0.04821 \times 1)$$

$$\underline{OA}: (94.97\%, 98.66\%)$$

$$\exp(-0.05163 \times 1) \leq \hat{R}(1) \leq \exp(-0.01349 \times 1).$$

The Bayesian Exponential Method.

Bayesian Exponential Prior. OT&E data are used to obtain a gamma prior. The mean and variance of the gamma distribution are $E(\lambda) = \alpha/\beta$ and $V(\lambda) = \alpha/\beta^2$. $E(\lambda)$ and $V(\lambda)$ can be estimated using the sample mean and variance of λ respectively. Thus α and β can be computed as $\alpha = E^2(\lambda)/V(\lambda)$ and $\beta = E(\lambda)/V(\lambda)$.

From Table B1:

$$\widehat{E}(\lambda) = \bar{\lambda} = \mathbf{0.05673} \text{ and } \widehat{V}(\lambda) = s_{\lambda^2} = \mathbf{0.00014}.$$

These yielded the parameter estimates

$$\alpha = \left(\frac{0.05673^2}{0.00014} \right) = \mathbf{23.28} \text{ and } \beta = \left(\frac{0.05673}{0.00014} \right) = \mathbf{405.21}.$$

Bayesian Exponential Posterior Analysis. The mean of the posterior distribution is the Bayesian point estimator. Under the squared error loss function, the Bayesian point estimator is

$$\widehat{\lambda} = E(\lambda|f; \alpha, \beta) = \left(\frac{f+a}{T+\beta} \right) = \left(\frac{4+23.28}{129.4+405.21} \right) = \mathbf{0.05103}.$$

The 80% two-sided probability interval (TBPI) is

$$\begin{aligned} & \left(\frac{\chi_{0.2/2}^2(2 \times 4 + 2 \times 23.28)}{2(129.4 + 405.21)}, \frac{\chi_{1-0.2/2}^2(2 \times 4 + 2 \times 23.28)}{2(129.4 + 405.21)} \right) \\ & = \left(\frac{41.18}{1069.22}, \frac{67.67}{1069.22} \right) = \mathbf{(0.03852, 0.06329)}. \end{aligned}$$

The Bayesian estimator of $R(t)$ for $t = 1$ hour is

$$\begin{aligned} \widehat{R}(t) &= \left(\frac{\left(\frac{T}{\beta} \right) + 1}{\left(\frac{T}{\beta} \right) + \left(\frac{t}{\beta} \right) + 1} \right)^{a+f} \\ &= \left(\frac{\left(\frac{129.4}{405.21} \right) + 1}{\left(\frac{129.4}{405.21} \right) + \left(\frac{1}{405.21} \right) + 1} \right)^{23.28+4} = \mathbf{95.03\%}. \end{aligned}$$

The 80% two-sided probability interval (TBPI) is

$$\exp(-0.06329 \times 1) \leq \widehat{R}(1) \leq \exp(-0.03852 \times 1)$$

$$\mathbf{(93.87\% \leq \widehat{R}(1) \leq 96.22\%)}.$$

Appendix C. Simulated Data For Series System.

DT Data Run #1

Time	Component Failure	Time	Component Failure
4.06	C3	244.08	C1
6.20	C2	245.78	C3
12.19	C2	247.35	C3
15.64	C1	262.18	C2
16.39	C1	278.38	C1
22.66	C2	279.89	C1
39.58	C1	280.96	C3
43.63	C3	282.47	C2
44.47	C3	288.81	C2
49.98	C2	296.84	C3
53.87	C2	308.01	C1
57.15	C1	308.60	C1
71.94	C1	310.25	C2
72.13	C1	316.96	C3
73.51	C3	329.51	C1
77.89	C3	333.17	C2
82.85	C2	336.92	C3
91.34	C1	340.08	C2
93.36	C3	343.54	C1
101.92	C3	362.98	C2
106.49	C2	369.64	C2
113.87	C1	373.05	C2
114.93	C2	379.03	C2
127.01	C1	395.63	C3
139.00	C3	396.23	C3
141.46	C2	400.42	C1
145.83	C1	407.82	C2
149.97	C3	411.09	C2
151.10	C2	415.78	C2
169.35	C2	421.76	C3
178.76	C1	426.12	C1
197.32	C3	430.44	C1
197.58	C2	433.82	C1
198.19	C3	444.57	C3
199.98	C3	461.05	C2
200.04	C1	485.22	C2
226.10	C3	495.04	C3
227.85	C2	496.78	C3
228.57	C3	497.25	C1
239.47	C3	499.86	C3

DT Data Run #2

Time	Component Failure	Time	Component Failure
12.04	C3	227.72	C3
12.07	C1	255.18	C3
18.71	C3	255.70	C2
24.93	C2	261.48	C3
31.60	C2	267.05	C2
32.47	C3	274.55	C1
32.66	C3	276.86	C1
37.16	C1	281.57	C1
37.68	C3	281.73	C2
41.33	C3	286.19	C3
53.45	C2	286.56	C1
64.13	C1	296.05	C3
73.42	C1	296.35	C2
75.56	C1	298.56	C2
87.54	C2	301.29	C3
87.78	C2	301.38	C1
88.24	C2	308.87	C1
93.96	C2	313.78	C2
97.05	C2	318.71	C1
99.47	C2	323.07	C3
135.04	C2	323.64	C3
139.54	C2	336.32	C1
154.84	C1	337.83	C1
159.06	C3	351.36	C1
161.17	C2	353.18	C1
165.41	C1	353.51	C2
173.80	C2	363.70	C3
183.58	C2	366.73	C2
185.59	C2	374.64	C2
187.10	C3	376.48	C2
189.16	C2	388.35	C2
195.88	C3	396.67	C2
198.87	C3	397.31	C1
199.44	C2	398.38	C2
204.14	C2	398.81	C2
206.88	C2	403.77	C2
207.29	C2	404.07	C3
224.62	C1	410.53	C3
225.61	C2	449.53	C2

DT Data Run #3

Time	Component Failure	Time	Component Failure
12.73	C2	171.78	C1
16.97	C1	176.02	C3
21.21	C3	207.53	C2
51.23	C2	220.65	C1
55.53	C2	224.89	C3
68.30	C1	225.93	C2
72.54	C3	272.35	C2
73.78	C2	276.70	C1
74.04	C1	280.94	C3
78.29	C3	285.39	C2
98.37	C1	301.25	C1
101.92	C2	305.49	C3
102.61	C3	308.09	C2
103.04	C2	324.04	C2
119.60	C2	330.31	C2
128.83	C2	330.52	C2
135.90	C1	348.70	C2
137.39	C1	363.13	C1
140.14	C3	367.37	C3
141.63	C3	372.01	C2
159.47	C1	377.28	C2
163.71	C3	380.51	C1
165.49	C2	384.76	C3

DT Data Run #4

Time	Component Failure	Time	Component Failure	Time	Component Failure
2.18	C2	137.72	C3	334.87	C2
2.39	C2	142.78	C2	338.17	C2
2.91	C1	155.78	C1	366.00	C1
3.12	C3	155.98	C3	366.21	C3
3.18	C1	187.69	C2	400.51	C2
3.39	C3	190.38	C1	405.11	C2
15.20	C2	190.58	C3	406.97	C2
20.27	C1	201.10	C2	407.45	C2
20.95	C2	206.01	C2	421.23	C2
27.89	C2	214.66	C2	432.10	C2
27.93	C1	224.39	C2	435.24	C2
28.13	C3	227.45	C2	435.88	C1
37.18	C1	242.22	C2	436.09	C3
37.39	C3	248.19	C2	446.39	C2
38.87	C2	250.25	C1	446.49	C1
42.58	C2	250.45	C3	446.69	C3
51.82	C1	268.14	C1	450.89	C1
52.03	C3	268.34	C3	451.09	C3
53.20	C2	274.50	C2	461.14	C2
56.77	C1	274.68	C1	473.75	C2
56.98	C3	274.88	C3	475.42	C2
62.50	C2	286.21	C1	517.25	C2
70.94	C1	286.41	C3	532.99	C2
71.14	C3	299.19	C1	534.02	C1
82.07	C2	299.39	C3	534.22	C3
83.33	C1	303.27	C1	534.39	C2
83.54	C3	303.47	C3	540.14	C1
103.14	C2	322.96	C1	540.35	C3
109.42	C1	323.17	C3	542.63	C1
109.63	C3	326.91	C2	542.83	C3
116.83	C2	330.92	C1	543.27	C1
137.52	C1	331.12	C3	543.47	C3

DT Data Run #5

Time	Component Failure	Time	Component Failure
2.04	C2	349.24	C2
2.72	C1	377.55	C2
3.40	C3	379.54	C1
7.41	C2	380.22	C3
9.88	C1	387.73	C2
10.56	C3	396.03	C1
27.19	C2	396.71	C3
36.25	C1	417.28	C2
36.93	C3	434.15	C1
133.50	C2	434.83	C3
145.89	C2	437.04	C1
146.74	C2	437.72	C3
148.39	C2	443.40	C2
178.00	C1	456.58	C2
178.68	C3	457.24	C1
188.27	C2	457.92	C3
194.52	C1	459.69	C2
195.20	C3	465.66	C1
195.65	C1	466.34	C3
196.33	C3	483.97	C2
197.85	C1	499.04	C2
198.53	C3	503.40	C1
234.22	C2	504.08	C3
234.27	C2	509.51	C2
243.58	C2	516.97	C1
251.03	C1	517.65	C3
251.71	C3	521.73	C2
284.65	C2	525.92	C2
297.02	C2	551.90	C2
312.30	C1	555.80	C2
312.37	C1	556.38	C1
312.98	C3	557.06	C3
313.04	C3	563.60	C2
324.77	C1	572.05	C2
325.45	C3	590.64	C2
325.61	C2	591.20	C1
327.78	C2	591.88	C3
342.93	C2		

OT Data Runs #1 and #2

OT Data Run #1		OT Data Run #2	
Time	Component Failure	Time	Component Failure
11.88	C2	27.30	C2
15.85	C1	31.95	C2
19.81	C3	36.40	C1
24.52	C2	41.05	C3
30.77	C2	42.60	C1
32.69	C1	45.94	C2
36.65	C3	47.25	C3
40.69	C2	47.72	C2
41.03	C1	58.60	C2
44.99	C3	61.25	C1
54.26	C1	63.62	C1
58.22	C3	65.90	C3
87.86	C2	68.27	C3
		76.87	C2
		78.14	C1
		82.79	C3
		87.02	C2
		88.69	C2
		92.19	C2
		102.49	C1
		105.31	C2
		107.14	C3
		116.03	C1
		118.26	C1
		120.68	C3
		122.91	C3
		122.92	C1

Appendix D. Calculation For Series System Reliability.

Consider a system composed of $k = 3$ independent components in series configuration. The time to failure of each component is assumed to be exponentially distributed. Let $\lambda_1 = 0.05$, $\lambda_2 = 0.067$, and $\lambda_3 = 0.05$ be the respective constant failure rates (failure per hour) of each component. The failure rate for the system is

$$\lambda = \sum_{i=1}^3 \lambda_i = 0.05 + 0.067 + 0.05 = \mathbf{0.167 \text{ failure per hour.}}$$

Thus the mean failure for the system is

$$E(\lambda) = \left(\frac{1}{\lambda}\right) = \left(\frac{1}{0.167}\right) = \mathbf{6 \text{ hours.}}$$

For the true system, using a mission time, t of one hour, the reliability of components 1, 2, and 3 are

$$R_1 = R_3 = \exp(-0.05) = \mathbf{95.12\%}$$

$$R_2 = \exp(-0.067) = \mathbf{93.52\%}.$$

The reliability of the system can be calculated as

$$R_s = R_1 \times R_2 \times R_3 = 95.12\% \times 93.52\% \times 95.12\% = \mathbf{84.62\%}$$

$$\text{or } R_s = \exp(-\lambda t) = \exp(-0.167) = \mathbf{84.62\%}.$$

Using a computer program called RAPTOR, which is developed by AFOTEC, to simulate the true system, the following data are obtained (to review the simulated data, see Appendix C):

Table D1: System Level DT Data

Run i	T_i Hours	X_i Failures	$\hat{\lambda}_i = X_i/T_i$
1	499.86	80	0.16005
2	449.53	78	0.17352
3	384.76	46	0.11956
4	543.47	97	0.17848
5	591.88	75	0.12672

Table D2: System Level OT Data

Run i	T_i Hours	X_i Failures	$\hat{\lambda}_i = X_i/T_i$
1	87.86	13	0.14796
2	122.92	27	0.21966

Table D3: Component 1 DT Data

Run i	T_i Hours	X_i Failures	$\hat{\lambda}_i = X_i/T_i$
1	499.86	24	0.04801
2	449.53	20	0.04449
3	384.76	13	0.03379
4	543.47	29	0.05336
5	591.88	21	0.03548

Table D4: Component 1 OT Data

Run i	T_i Hours	X_i Failures	$\hat{\lambda}_i = X_i/T_i$
1	87.86	4	0.04553
2	122.92	9	0.07322

Table D5: Component 2 DT Data

Run i	T_i Hours	X_i Failures	$\hat{\lambda}_i = X_i/T_i$
1	499.86	28	0.05602
2	449.53	37	0.08231
3	384.76	20	0.05198
4	543.47	39	0.07176
5	591.88	33	0.05576

Table D6: Component 2 OT Data

Run i	T_i Hours	X_i Failures	$\hat{\lambda}_i = X_i/T_i$
1	87.86	5	0.05691
2	122.92	10	0.08135

Table D7: Component 3 DT Data

Run i	T_i Hours	X_i Failures	$\hat{\lambda}_i = X_i/T_i$
1	499.86	28	0.05602
2	449.53	21	0.04672
3	384.76	13	0.03379
4	543.47	29	0.05336
5	591.88	21	0.03548

Table D8: Component 3 OT Data

Run i	T _i Hours	X _i Failures	$\hat{\lambda}_i = X_i/T_i$
1	87.86	4	0.04553
2	122.92	8	0.06508

The Bayesian Method 1.

Bayesian Prior Analysis. Assuming that the prior belief about the failure rates λ_i ($i = 1, 2, 3$) is exponentially distributed with parameter θ . Then the prior

belief about $\lambda = \sum_{i=1}^3 \lambda_i$ is defined by a gamma distribution with pdf given in Equation 27. The mean of the system is $E(\lambda) = k/\theta$. With $E(\lambda) = 6$ from above, solving for θ to

$$\text{obtain } \theta = \left(\frac{k}{E(\lambda)} \right) = \left(\frac{3}{6} \right) = 0.5.$$

Bayesian Posterior Analysis.

At the system level OT data, there are 40 failures ($f_2 = 40$) observed during the total test time $T_2 = 210.78$ hours, $k = 3$ and $\lambda = 0.167$ failure per hour. Thus

$$\hat{\lambda} = E(\lambda | f) = \left(\frac{f+k}{T+\theta} \right) = \left(\frac{40+3}{210.78+0.5} \right) = 0.20352.$$

At the system level OT data, there are 40 failures ($f_2 = 40$) observed during the total test time $T_2 = 210.78$ hours, $k = 3$ and $\lambda = 0.167$ failure per hour. Thus

$$\hat{R}(t) = \left(\frac{1}{1 + \left(\frac{1}{210.78+0.5} \right)} \right)^{40+3} = 0.8162.$$

Computations Using The Exponential Model.

The Classical Exponential Method. Assuming the time to failure of each component has the exponential distribution, point estimates for the failure rate λ and 80% confidence intervals about λ will be computed.

$$\text{System Level DT: } \hat{\lambda} = \left(\frac{f_1}{T_1} \right) = \left(\frac{376}{2469.5} \right) = \mathbf{0.15226}$$

$$\text{System Level OT: } \hat{\lambda} = \left(\frac{f_2}{T_2} \right) = \left(\frac{40}{210.78} \right) = \mathbf{0.18977}$$

$$\text{Component 1 DT: } \hat{\lambda} = \left(\frac{f_3}{T_3} \right) = \left(\frac{107}{2469.5} \right) = \mathbf{0.04333}$$

$$\text{Component 1 OT: } \hat{\lambda} = \left(\frac{f_4}{T_4} \right) = \left(\frac{13}{210.78} \right) = \mathbf{0.06168}$$

$$\text{Component 2 DT: } \hat{\lambda} = \left(\frac{f_5}{T_5} \right) = \left(\frac{157}{2469.5} \right) = \mathbf{0.06358}$$

$$\text{Component 2 OT: } \hat{\lambda} = \left(\frac{f_6}{T_6} \right) = \left(\frac{15}{210.78} \right) = \mathbf{0.07116}$$

$$\text{Component 3 DT: } \hat{\lambda} = \left(\frac{f_7}{T_7} \right) = \left(\frac{112}{2469.5} \right) = \mathbf{0.04535}$$

$$\text{Component 3 OT: } \hat{\lambda} = \left(\frac{f_8}{T_8} \right) = \left(\frac{12}{210.78} \right) = \mathbf{0.05693}$$

where $f_1 = 376$ is the number of failures and $T_1 = 2469.5$ is the total test time from Table D1 and similarly $f_2 = 40$ and $T_2 = 210.78$ from Table D2, $f_3 = 107$ and $T_3 = 2469.5$ from Table D3, $f_4 = 13$ and $T_4 = 210.78$ from Table D4, $f_5 = 157$ and $T_5 = 2469.5$ from Table D5, $f_6 = 15$ and $T_6 = 210.78$ from Table D6, $f_7 = 112$ and $T_7 = 2469.5$ from Table D7, $f_8 = 12$ and $T_8 = 210.78$ from Table D8.

The 80% two-sided confidence intervals (TCI) are

System Level DT: (0.14229, 0.16240)

$$\left(\frac{\chi_{0.2/2}^2(2 \times 376)}{2 \times 2469.5}, \frac{\chi_{1-0.2/2}^2(2 \times 376)}{2 \times 2469.5} \right) = \left(\frac{702.75}{4939}, \frac{802.11}{4939} \right)$$

System Level OT: (0.15248, 0.22910)

$$\left(\frac{\chi_{0.2/2}^2(2 \times 40)}{2 \times 210.78}, \frac{\chi_{1-0.2/2}^2(2 \times 40)}{2 \times 210.78} \right) = \left(\frac{64.28}{421.56}, \frac{96.58}{421.56} \right)$$

Component 1 DT: (0.03806, 0.04878)

$$\left(\frac{\chi_{0.2/2}^2(2 \times 107)}{2 \times 2469.5}, \frac{\chi_{1-0.2/2}^2(2 \times 107)}{2 \times 2469.5} \right) = \left(\frac{187.95}{4939}, \frac{240.9}{4939} \right)$$

Component 1 OT: (0.04102, 0.08436)

$$\left(\frac{\chi_{0.2/2}^2(2 \times 13)}{2 \times 210.78}, \frac{\chi_{1-0.2/2}^2(2 \times 13)}{2 \times 210.78} \right) = \left(\frac{17.29}{421.56}, \frac{35.56}{421.56} \right)$$

Component 2 DT: (0.05717, 0.07016)

$$\left(\frac{\chi_{0.2/2}^2(2 \times 157)}{2 \times 2469.5}, \frac{\chi_{1-0.2/2}^2(2 \times 157)}{2 \times 2469.5} \right) = \left(\frac{282.34}{4939}, \frac{346.51}{4939} \right)$$

Component 2 OT: (0.04886, 0.09549)

$$\left(\frac{\chi_{0.2/2}^2(2 \times 15)}{2 \times 210.78}, \frac{\chi_{1-0.2/2}^2(2 \times 15)}{2 \times 210.78} \right) = \left(\frac{20.6}{421.56}, \frac{40.26}{421.56} \right)$$

Component 3 DT: (0.03996, 0.05093)

$$\left(\frac{\chi_{0.2/2}^2(2 \times 112)}{2 \times 2469.5}, \frac{\chi_{1-0.2/2}^2(2 \times 112)}{2 \times 2469.5} \right) = \left(\frac{197.34}{4939}, \frac{251.52}{4939} \right)$$

Component 3 OT: (0.03715, 0.07875)

$$\left(\frac{\chi_{0.2/2}^2(2 \times 12)}{2 \times 210.78}, \frac{\chi_{1-0.2/2}^2(2 \times 12)}{2 \times 210.78} \right) = \left(\frac{15.66}{421.56}, \frac{33.2}{421.56} \right)$$

The reliability estimators of $R(t)$ for $t = 1$ hour are

System Level DT: $\widehat{R}(t) = \exp(-0.15226 \times 1) = 85.88\%$

System Level OT: $\widehat{R}(t) = \exp(-0.18977 \times 1) = 82.72\%$

Component 1 DT: $\widehat{R}_1(t) = \exp(-0.04333 \times 1) = 95.76\%$

Component 1 OT: $\widehat{R}_1(t) = \exp(-0.06168 \times 1) = 94.02\%$

Component 2 DT: $\widehat{R}_2(t) = \exp(-0.06358 \times 1) = 93.84\%$

Component 2 OT: $\widehat{R}_2(t) = \exp(-0.07116 \times 1) = 93.13\%$

Component 3 DT: $\widehat{R}_3(t) = \exp(-0.04535 \times 1) = 95.57\%$

Component 3 OT: $\widehat{R}_3(t) = \exp(-0.05693 \times 1) = 94.47\%$

Component Level Aggregated to System DT: $\widehat{R}(t) = 85.88\%$

$\widehat{R}(t) = R_1 * R_2 * R_3 = 0.9576 * 0.9384 * 0.9557 = 0.8588$

Component Level Aggregated to System OT: $\widehat{R}(t) = 82.72\%$

$\widehat{R}(t) = R_1 * R_2 * R_3 = 0.9402 * 0.9313 * 0.9447 = 0.8272.$

The 80% two-sided confidence intervals (TCI) are

System Level DT: **(85.01%, 86.74%)**

$\exp(-0.16240 \times 1) \leq \widehat{R}(1) \leq \exp(-0.14229 \times 1)$

System Level OT: **(79.53%, 85.86%)**

$\exp(-0.22910 \times 1) \leq \widehat{R}(1) \leq \exp(-0.15248 \times 1)$

Component 1 DT: **(95.24%, 96.27%)**

$\exp(-0.04878 \times 1) \leq \widehat{R}(1) \leq \exp(-0.03806 \times 1)$

Component 1 OT: **(91.91%, 95.98%)**

$\exp(-0.08436 \times 1) \leq \widehat{R}(1) \leq \exp(-0.04102 \times 1)$

Component 2 DT: **(93.22%, 94.44%)**

$$\exp(-0.07016X1) \leq \hat{R}(1) \leq \exp(-0.05717X1)$$

Component 2 OT: (90.89%, 95.23%)

$$\exp(-0.09549X1) \leq \hat{R}(1) \leq \exp(-0.04886X1)$$

Component 3 DT: (95.03%, 96.08%)

$$\exp(-0.05093X1) \leq \hat{R}(1) \leq \exp(-0.03996X1)$$

Component 3 OT: (92.43%, 96.35%)

$$\exp(-0.07875X1) \leq \hat{R}(1) \leq \exp(-0.03715X1)$$

Component Level Aggregated to System DT:

(84.37%, 87.35%)

$$\text{Lower Bound} = 0.9524 * 0.9322 * 0.9503 = 0.8437$$

$$\text{Upper Bound} = 0.9627 * 0.9444 * 0.9608 = 0.8735$$

Component Level Aggregated to System OT:

(77.21%, 88.07%)

$$\text{Lower Bound} = 0.9191 * 0.9089 * 0.9243 = 0.7721$$

$$\text{Upper Bound} = 0.9598 * 0.9523 * 0.9635 = 0.8807.$$

The Bayesian Exponential Method.

Bayesian Exponential Prior.

For the system level data, from Table D1:

$$\hat{E}(\lambda) = \bar{\lambda} = \mathbf{0.15166} \text{ and } \hat{V}(\lambda) = s_{\lambda}^2 = \mathbf{0.00073}.$$

These yielded the parameter estimates

$$\alpha = \left(\frac{0.15166^2}{0.00073} \right) = \mathbf{31.51} \text{ and } \beta = \left(\frac{0.15166}{0.00073} \right) = \mathbf{207.76}.$$

For Component 1 data, from Table D3:

$$\widehat{E}(\lambda) = \overline{\lambda} = \mathbf{0.04303} \text{ and } \widehat{V}(\lambda) = s_{\lambda}^2 = \mathbf{0.00007}.$$

These yielded the parameter estimates

$$\alpha = \left(\frac{0.04303^2}{0.00007} \right) = \mathbf{26.83} \text{ and } \beta = \left(\frac{0.04303}{0.00007} \right) = \mathbf{623.58}.$$

For Component 2 data, from Table D5:

$$\widehat{E}(\lambda) = \overline{\lambda} = \mathbf{0.06356} \text{ and } \widehat{V}(\lambda) = s_{\lambda}^2 = \mathbf{0.00017}.$$

These yielded the parameter estimates

$$\alpha = \left(\frac{0.06356^2}{0.00017} \right) = \mathbf{23.76} \text{ and } \beta = \left(\frac{0.06356}{0.00017} \right) = \mathbf{373.88}.$$

For Component 3 data, from Table D7:

$$\widehat{E}(\lambda) = \overline{\lambda} = \mathbf{0.04507} \text{ and } \widehat{V}(\lambda) = s_{\lambda}^2 = \mathbf{0.0001}.$$

These yielded the parameter estimates

$$\alpha = \left(\frac{0.04507^2}{0.0001} \right) = \mathbf{20.31} \text{ and } \beta = \left(\frac{0.04507}{0.0001} \right) = \mathbf{450.7}.$$

Bayesian Exponential Posterior Analysis.

$$\text{System Level: } \hat{\lambda} = \left(\frac{40+31.51}{210.78+207.76} \right) = \mathbf{0.17086}.$$

$$\text{Component 1: } \hat{\lambda} = \left(\frac{13+26.83}{210.78+623.58} \right) = \mathbf{0.04774}.$$

$$\text{Component 2: } \hat{\lambda} = \left(\frac{15+23.76}{210.78+373.88} \right) = \mathbf{0.06630}.$$

$$\text{Component 3: } \hat{\lambda} = \left(\frac{12+20.31}{210.78+450.7} \right) = \mathbf{0.04885}.$$

The 80% two-sided probability intervals (TBPI) are

$$\text{System Level: } \left(\frac{\chi_{0.2/2}^2(2 \times 40 + 2 \times 31.51)}{2(210.78 + 207.76)}, \frac{\chi_{1-0.2/2}^2(2 \times 40 + 2 \times 31.51)}{2(210.78 + 207.76)} \right)$$

$$= \left(\frac{121.8}{837.08}, \frac{165.06}{837.08} \right) = \mathbf{(0.14551, 0.19718)}.$$

$$\begin{aligned} \text{Component 1: } & \left(\frac{\chi_{0.2/2}^2(2 \times 13 + 2 \times 26.83)}{2(210.78 + 623.58)}, \frac{\chi_{1-0.2/2}^2(2 \times 13 + 2 \times 26.83)}{2(210.78 + 623.58)} \right) \\ & = \left(\frac{63.38}{1668.72}, \frac{95.48}{1668.72} \right) = (0.03798, 0.05722). \end{aligned}$$

$$\begin{aligned} \text{Component 2: } & \left(\frac{\chi_{0.2/2}^2(2 \times 15 + 2 \times 23.76)}{2(210.78 + 373.88)}, \frac{\chi_{1-0.2/2}^2(2 \times 15 + 2 \times 23.76)}{2(210.78 + 373.88)} \right) \\ & = \left(\frac{61.59}{1169.32}, \frac{93.27}{1169.32} \right) = (0.05267, 0.07976). \end{aligned}$$

$$\begin{aligned} \text{Component 3: } & \left(\frac{\chi_{0.2/2}^2(2 \times 12 + 2 \times 20.31)}{2(210.78 + 450.7)}, \frac{\chi_{1-0.2/2}^2(2 \times 12 + 2 \times 20.31)}{2(210.78 + 450.7)} \right) \\ & = \left(\frac{50}{1322.96}, \frac{78.86}{1322.96} \right) = (0.03779, 0.05961). \end{aligned}$$

The Bayesian estimators of $R(t)$ for $t = 1$ hour are

System Level: $\hat{R}(t) = 84.31\%$

$$\hat{R}(t) = \left(\frac{\left(\frac{210.78}{207.76} \right) + 1}{\left(\frac{210.78}{207.76} \right) + \left(\frac{1}{207.76} \right) + 1} \right)^{31.51+40}$$

Component 1: $\hat{R}(t) = 95.34\%$

$$\hat{R}(t) = \left(\frac{\left(\frac{210.78}{623.58} \right) + 1}{\left(\frac{210.78}{623.58} \right) + \left(\frac{1}{623.58} \right) + 1} \right)^{26.83+13}$$

Component 2: $\hat{R}(t) = 93.59\%$

$$\hat{R}(t) = \left(\frac{\left(\frac{210.78}{373.88} \right) + 1}{\left(\frac{210.78}{373.88} \right) + \left(\frac{1}{373.88} \right) + 1} \right)^{23.76+15}$$

Component 3: $\hat{R}(t) = 95.24\%$

$$\hat{R}(t) = \left(\frac{\left(\frac{210.78}{450.7} \right) + 1}{\left(\frac{210.78}{450.7} \right) + \left(\frac{1}{450.7} \right) + 1} \right)^{20.31+12}$$

Component Level Aggregated to System: $\hat{R}(t) = 84.98\%$

$$\hat{R}(t) = 0.9534 * 0.9359 * 0.9524 = 0.8498$$

The 80% two-sided probability intervals (TBPI) are

System Level: $(82.10\% \leq \hat{R}(1) \leq 86.46\%)$

$$\exp(-0.19718 \times 1) \leq \hat{R}(1) \leq \exp(-0.14551 \times 1).$$

Component 1: $(94.44\% \leq \hat{R}(1) \leq 96.27\%)$

$$\exp(-0.05722 \times 1) \leq \hat{R}(1) \leq \exp(-0.03798 \times 1).$$

Component 2: $(92.33\% \leq \hat{R}(1) \leq 94.87\%)$

$$\exp(-0.07976 \times 1) \leq \hat{R}(1) \leq \exp(-0.05267 \times 1).$$

Component 3: $(94.21\% \leq \hat{R}(1) \leq 96.29\%)$

$$\exp(-0.05961 \times 1) \leq \hat{R}(1) \leq \exp(-0.03779 \times 1).$$

Component Level Aggregated to System:

$$(82.15\% \leq \hat{R}(1) \leq 87.94\%)$$

$$0.9444 * 0.9233 * 0.9421 \leq \hat{R}(1) \leq 0.9627 * 0.9487 * 0.9629.$$

**Appendix E. Simulated Data For Parallel System With
Independent And Identical Components.**

DT Data Run #1

Time	Component Failure	Time	Component Failure
12.04	C3	282.71	C2
12.06	C1	289.01	C2
18.71	C3	291.78	C3
32.47	C3	296.17	C1
33.23	C2	304.14	C2
37.16	C1	306.46	C2
37.35	C1	311.16	C2
41.36	C3	315.75	C1
42.37	C1	316.15	C2
46.02	C1	316.49	C3
62.38	C2	326.02	C2
68.33	C3	331.25	C2
77.62	C3	331.31	C3
79.76	C3	334.20	C2
107.82	C2	335.24	C1
108.15	C2	342.72	C1
108.76	C2	351.61	C3
116.38	C2	352.56	C1
120.51	C2	355.99	C2
123.73	C2	356.56	C2
159.04	C3	370.17	C1
163.75	C1	371.68	C1
165.04	C3	385.22	C1
171.15	C2	387.04	C1
175.61	C3	396.62	C2
192.46	C3	404.57	C3
192.59	C1	414.25	C2
199.20	C2	424.79	C2
201.88	C2	427.24	C2
205.62	C1	431.17	C1
206.64	C2	442.25	C1
214.41	C1	443.08	C2
217.39	C1	444.53	C1
220.35	C2	444.94	C3
226.62	C2	445.11	C1
230.28	C2	451.56	C3
230.81	C2	458.01	C3
246.24	C1	495.84	C2
251.66	C3	497.94	C3
255.25	C2	497.94	C2

DT Data Run #2

Time	Component Failure	Time	Component Failure
4.20	C3	275.50	C2
4.58	C1	281.06	C1
6.07	C2	290.49	C3
17.53	C2	295.71	C2
18.43	C1	304.23	C1
34.77	C3	306.66	C1
46.48	C3	313.05	C2
57.70	C2	336.41	C2
62.53	C3	336.81	C1
68.69	C1	337.86	C3
75.71	C2	344.63	C1
90.38	C3	351.90	C2
90.50	C1	361.93	C1
91.35	C2	363.04	C1
93.99	C3	365.05	C2
94.21	C1	368.64	C2
105.29	C3	389.02	C3
107.87	C1	391.29	C1
110.82	C3	398.75	C2
114.35	C3	403.27	C2
135.40	C2	415.59	C2
142.04	C1	425.97	C3
142.34	C1	427.24	C1
153.25	C1	428.28	C2
159.69	C2	429.95	C1
161.91	C1	431.16	C1
168.85	C2	441.17	C2
170.29	C2	449.38	C2
177.01	C3	451.03	C3
208.26	C1	455.09	C2
216.50	C3	458.15	C2
218.39	C1	459.00	C2
224.21	C2	459.80	C1
230.03	C3	463.57	C2
230.64	C1	464.11	C1
248.50	C2	475.82	C3
270.19	C3	487.71	C2
274.10	C2		

DT Data Run #3

Time	Component Failure	Time	Component Failure
9.08	C2	255.75	C3
12.18	C3	259.70	C1
26.30	C1	261.80	C3
40.09	C3	266.50	C1
40.41	C3	288.06	C2
61.50	C2	288.64	C3
61.75	C3	292.05	C2
64.21	C2	294.44	C3
69.80	C3	295.71	C1
71.06	C3	334.44	C2
71.24	C1	334.85	C2
74.24	C2	336.79	C2
105.08	C2	356.86	C1
110.15	C2	357.14	C1
110.28	C3	366.86	C3
122.39	C1	367.70	C3
123.14	C2	371.11	C1
134.03	C3	376.81	C3
138.38	C3	378.97	C2
142.06	C3	380.16	C1
168.67	C1	381.50	C1
169.65	C3	385.48	C1
172.87	C1	389.79	C1
179.59	C2	392.03	C1
189.06	C3	401.88	C2
189.37	C1	436.54	C2
192.59	C2	448.39	C3
217.46	C2	448.48	C1
220.53	C2	460.88	C1
221.95	C2	494.32	C3
233.27	C1	494.72	C1
237.80	C2	495.58	C3
251.11	C3	497.53	C1

DT Data Run #4

Time	Component Failure	Time	Component Failure
7.12	C3	250.70	C3
22.95	C1	256.25	C1
36.55	C1	262.69	C1
37.98	C3	278.48	C2
55.79	C3	280.28	C3
59.30	C2	281.44	C2
70.99	C3	286.02	C3
77.46	C1	291.79	C3
96.21	C2	299.82	C2
100.76	C3	300.73	C3
104.27	C2	302.40	C3
105.69	C1	321.65	C3
112.94	C2	324.77	C3
120.84	C3	327.33	C3
124.10	C2	338.50	C1
125.88	C1	349.24	C2
130.52	C2	357.36	C1
130.76	C3	360.37	C3
144.16	C1	365.21	C2
150.61	C3	366.03	C2
154.18	C3	366.04	C1
156.54	C1	380.64	C2
163.03	C1	389.64	C2
166.15	C1	418.84	C3
167.21	C1	427.39	C1
179.93	C2	429.46	C3
195.27	C3	437.45	C3
201.07	C3	449.55	C1
203.93	C2	455.18	C3
204.56	C2	455.99	C1
205.88	C3	475.72	C3
215.39	C3	479.32	C3
228.63	C2	491.46	C1
243.40	C1	494.00	C3
245.96	C3	496.95	C2

DT Data Run #5

Time	Component Failure	Time	Component Failure
10.07	C1	311.09	C1
38.94	C1	311.42	C1
51.73	C3	312.23	C3
57.02	C3	317.40	C1
59.39	C1	321.72	C2
73.67	C2	325.49	C2
77.17	C2	338.23	C1
79.56	C2	343.49	C2
81.77	C1	346.16	C3
83.79	C2	351.11	C3
102.76	C2	359.99	C2
111.46	C1	364.48	C3
113.76	C2	367.25	C2
117.40	C3	373.64	C1
120.92	C2	374.40	C3
140.39	C1	376.93	C2
140.93	C3	384.09	C2
143.52	C3	394.25	C1
143.67	C3	401.81	C2
150.00	C1	402.77	C3
153.58	C1	417.35	C3
157.12	C1	418.39	C3
160.97	C2	422.69	C3
164.65	C3	425.16	C2
185.65	C3	426.57	C2
186.87	C3	437.34	C1
188.08	C1	438.51	C1
190.84	C2	442.89	C2
192.22	C3	443.85	C3
197.47	C3	444.85	C1
199.83	C2	447.39	C3
200.71	C1	449.22	C2
202.67	C2	455.79	C3
203.83	C1	457.86	C1
215.12	C3	460.98	C3
222.97	C3	462.83	C1
243.53	C3	479.77	C2
266.85	C3	486.68	C2
275.75	C2	490.60	C2
276.66	C3	496.86	C3
302.19	C2		

OT Data Runs #1 and #2

OT Data Run #1		OT Data Run #2	
Time	Component Failure	Time	Component Failure
4.06	C3	11.34	C3
8.27	C2	18.10	C3
15.64	C1	29.26	C3
16.26	C2	35.38	C2
17.01	C2	36.41	C3
29.60	C1	51.17	C3
40.19	C2	55.38	C1
43.63	C3	75.49	C1
44.47	C3	79.78	C2
57.77	C2	84.86	C1
62.95	C2	88.63	C2
66.03	C1	96.55	C3
73.51	C3	103.25	C2
73.69	C3	111.41	C2
80.82	C1	115.54	C2
85.21	C1		
92.91	C3		
100.67	C1		
101.59	C2		
110.15	C2		
123.20	C1		
124.42	C3		

**Appendix F. Calculation For Parallel System Reliability
With Independent and Identical Components.**

Consider a system composed of $k = 3$ independent and identical components in parallel configuration. The time to failure of each component is assumed to be exponentially distributed. Let $\lambda = 0.05$ failure per hour be the respective constant failure rates of each component.

For the true system, using a mission time, t of one hour, the reliability of components 1, 2, and 3 are

$$R_c = R_1 = R_2 = R_3 = \exp(-0.05) = \mathbf{95.12\%}.$$

The reliability of the system can be calculated as

$$R_s = 1 - (1 - R_c)^3 = 1 - (1 - 95.12\%)^3 = \mathbf{99.9884\%}.$$

Using a computer program called RAPTOR, which is developed by AFOTEC, to simulate the true system, the following data are obtained (to review the simulated data, see Appendix E):

Table F1: Aggregated Components DT Data

Run i	T_i Hours	X_i Failures	$\widehat{\lambda}_i = X_i/T_i$
1	1,493.82	79	0.05289
2	1,463.13	75	0.05126
3	1,492.59	66	0.04422
4	1,490.85	70	0.04695
5	1,490.58	81	0.05434

Table F2: Aggregated Components OT Data

Run i	T_i Hours	X_i Failures	$\widehat{\lambda}_i = X_i/T_i$
1	373.26	22	0.05894
2	346.62	15	0.04328

Table F3: Component 1 DT Data

Run i	T _i Hours	X _i Failures	$\hat{\lambda}_i = X_i/T_i$
1	497.94	24	0.04820
2	487.71	26	0.05331
3	497.53	22	0.04422
4	496.95	20	0.04025
5	496.86	23	0.04629

Table F4: Component 1 OT Data

Run i	T _i Hours	X _i Failures	$\hat{\lambda}_i = X_i/T_i$
1	124.42	7	0.05626
2	115.54	3	0.02597

Table F5: Component 2 DT Data

Run i	T _i Hours	X _i Failures	$\hat{\lambda}_i = X_i/T_i$
1	497.94	35	0.07029
2	487.71	30	0.06151
3	497.53	21	0.04221
4	496.95	19	0.03823
5	496.86	28	0.05635

Table F6: Component 2 OT Data

Run i	T _i Hours	X _i Failures	$\hat{\lambda}_i = X_i/T_i$
1	124.42	8	0.06430
2	115.54	6	0.05193

Table F7: Component 3 DT Data

Run i	T _i Hours	X _i Failures	$\hat{\lambda}_i = X_i/T_i$
1	497.94	20	0.04017
2	487.71	19	0.03896
3	497.53	23	0.04623
4	496.95	31	0.06238
5	496.86	30	0.06038

Table F8: Component 3 OT Data

Run i	T _i Hours	X _i Failures	$\hat{\lambda}_i = X_i/T_i$
1	124.42	7	0.05626
2	115.54	6	0.05193

The Classical Exponential Method. Assuming the time to failure of each component has the exponential distribution, point estimates for the failure rate λ and 80% confidence interval about λ will be computed.

$$\text{Component Aggregated DT: } \hat{\lambda} = \left(\frac{371}{7430.97} \right) = \mathbf{0.04993}$$

$$\text{Component Aggregated OT: } \hat{\lambda} = \left(\frac{37}{719.88} \right) = \mathbf{0.05140}$$

$$\text{Component 1 DT: } \hat{\lambda} = \left(\frac{f_3}{T_3} \right) = \left(\frac{115}{2476.99} \right) = \mathbf{0.04643}$$

$$\text{Component 1 OT: } \hat{\lambda} = \left(\frac{f_4}{T_4} \right) = \left(\frac{10}{239.96} \right) = \mathbf{0.04167}$$

$$\text{Component 2 DT: } \hat{\lambda} = \left(\frac{f_5}{T_5} \right) = \left(\frac{133}{2476.99} \right) = \mathbf{0.05369}$$

$$\text{Component 2 OT: } \hat{\lambda} = \left(\frac{f_6}{T_6} \right) = \left(\frac{14}{239.96} \right) = \mathbf{0.05834}$$

$$\text{Component 3 DT: } \hat{\lambda} = \left(\frac{f_7}{T_7} \right) = \left(\frac{123}{2476.99} \right) = \mathbf{0.04966}$$

$$\text{Component 3 OT: } \hat{\lambda} = \left(\frac{f_8}{T_8} \right) = \left(\frac{13}{239.96} \right) = \mathbf{0.05418}$$

where $f_1 = 371$ is the number of failures and $T_1 = 7430.97$ is the total test time from Table F1 and similarly $f_2 = 37$ and $T_2 = 719.88$ from Table F2, $f_3 = 115$ and $T_3 = 2476.99$ from Table F3, $f_4 = 10$ and $T_4 = 239.96$ from Table F4, $f_5 = 133$ and $T_5 = 2476.99$ from Table F5, $f_6 = 14$ and $T_6 = 239.96$ from Table F6, $f_7 = 123$ and $T_7 = 2476.99$ from Table F7, $f_8 = 13$ and $T_8 = 239.96$ from Table F8.

The 80% two-sided confidence intervals (TCI) are

Component Aggregated DT: (0.04664, 0.05328)

$$\left(\frac{\chi_{0.2/2}^2(2 \times 371)}{2 \times 7430.97}, \frac{\chi_{1-0.2/2}^2(2 \times 371)}{2 \times 7430.97} \right) = \left(\frac{693.08}{14861.94}, \frac{791.78}{14861.94} \right)$$

Component Aggregated OT: (0.04091, 0.06248)

$$\left(\frac{\chi_{0.2/2}^2(2 \times 37)}{2 \times 719.88}, \frac{\chi_{1-0.2/2}^2(2 \times 37)}{2 \times 719.88} \right) = \left(\frac{58.9}{1439.76}, \frac{89.96}{1439.76} \right)$$

Component 1 DT: (0.04097, 0.05206)

$$\left(\frac{\chi_{0.2/2}^2(2 \times 115)}{2 \times 2476.99}, \frac{\chi_{1-0.2/2}^2(2 \times 115)}{2 \times 2476.99} \right) = \left(\frac{202.98}{4953.98}, \frac{257.88}{4953.98} \right)$$

Component 1 OT: (0.02593, 0.05920)

$$\left(\frac{\chi_{0.2/2}^2(2 \times 10)}{2 \times 239.96}, \frac{\chi_{1-0.2/2}^2(2 \times 10)}{2 \times 239.96} \right) = \left(\frac{12.44}{479.92}, \frac{28.41}{479.92} \right)$$

Component 2 DT: (0.04782, 0.05974)

$$\left(\frac{\chi_{0.2/2}^2(2 \times 133)}{2 \times 2476.99}, \frac{\chi_{1-0.2/2}^2(2 \times 133)}{2 \times 2476.99} \right) = \left(\frac{236.90}{4953.98}, \frac{295.95}{4953.98} \right)$$

Component 2 OT: (0.03946, 0.07901)

$$\left(\frac{\chi_{0.2/2}^2(2 \times 14)}{2 \times 239.96}, \frac{\chi_{1-0.2/2}^2(2 \times 14)}{2 \times 239.96} \right) = \left(\frac{18.94}{479.92}, \frac{37.92}{479.92} \right)$$

Component 3 DT: (0.04401, 0.05548)

$$\left(\frac{\chi_{0.2/2}^2(2 \times 123)}{2 \times 2476.99}, \frac{\chi_{1-0.2/2}^2(2 \times 123)}{2 \times 2476.99} \right) = \left(\frac{218.04}{4953.98}, \frac{274.82}{4953.98} \right)$$

Component 3 OT: (0.03603, 0.07410)

$$\left(\frac{\chi_{0.2/2}^2(2 \times 13)}{2 \times 239.96}, \frac{\chi_{1-0.2/2}^2(2 \times 13)}{2 \times 239.96} \right) = \left(\frac{17.29189}{479.92}, \frac{35.56317}{479.92} \right)$$

The reliability estimators of $R(t)$ for $t = 1$ hour are

Component Aggregated DT:

$$\widehat{R}_c(t) = \exp(-0.04993 \times 1) = \mathbf{95.13\%}$$

Component Aggregated OT:

$$\widehat{R}_c(t) = \exp(-0.05140 \times 1) = \mathbf{94.99\%}$$

Component 1 DT: $\widehat{R}_1(t) = \exp(-0.04643 \times 1) = \mathbf{95.46\%}$

Component 1 OT: $\widehat{R}_1(t) = \exp(-0.04167 \times 1) = \mathbf{95.92\%}$

Component 2 DT: $\widehat{R}_2(t) = \exp(-0.05369 \times 1) = \mathbf{94.77\%}$

Component 2 OT: $\widehat{R}_2(t) = \exp(-0.05834 \times 1) = \mathbf{94.33\%}$

Component 3 DT: $\widehat{R}_3(t) = \exp(-0.04966 \times 1) = \mathbf{95.16\%}$

Component 3 OT: $\widehat{R}_3(t) = \exp(-0.05418 \times 1) = \mathbf{94.73\%}$

Aggregated Component to System DT: $\widehat{R}(t) = \mathbf{99.9885\%}$

$$\widehat{R}(t) = 1 - (1 - R_c)^3 = 1 - (1 - 95.13\%)^3 = 0.999885$$

Aggregated Component to System OT: $\widehat{R}(t) = \mathbf{99.9874\%}$

$$\widehat{R}(t) = 1 - (1 - R_c)^3 = 1 - (1 - 94.99\%)^3 = 0.999874$$

Component Level Aggregated to System DT:

$$\begin{aligned} \widehat{R}(t) &= 1 - (1 - R_1)(1 - R_2)(1 - R_3) \\ &= 1 - (1 - 0.9546)(1 - 0.9477)(1 - 0.9516) = \mathbf{99.9885\%} \end{aligned}$$

Component Level Aggregated to System OT:

$$\begin{aligned} \widehat{R}(t) &= 1 - (1 - R_1)(1 - R_2)(1 - R_3) \\ &= 1 - (1 - 0.9592)(1 - 0.9433)(1 - 0.9473) = \mathbf{99.9878\%} \end{aligned}$$

The 80% two-sided confidence intervals (TCI) are

Aggregated Component DT: **(94.81%, 95.44%)**

$$\exp(-0.05328X1) \leq \hat{R}(1) \leq \exp(-0.04664X1)$$

Aggregated Component OT: **(93.94%, 95.99%)**

$$\exp(-0.06248X1) \leq \hat{R}(1) \leq \exp(-0.04091X1)$$

Component 1 DT: **(94.93%, 95.99%)**

$$\exp(-0.05206X1) \leq \hat{R}(1) \leq \exp(-0.04097X1)$$

Component 1 OT: **(94.25%, 97.44%)**

$$\exp(-0.05920X1) \leq \hat{R}(1) \leq \exp(-0.02593X1)$$

Component 2 DT: **(94.20%, 95.33%)**

$$\exp(-0.05974X1) \leq \hat{R}(1) \leq \exp(-0.04782X1)$$

Component 2 OT: **(92.40%, 96.13%)**

$$\exp(-0.07901X1) \leq \hat{R}(1) \leq \exp(-0.03946X1)$$

Component 3 DT: **(94.60%, 95.69%)**

$$\exp(-0.05548X1) \leq \hat{R}(1) \leq \exp(-0.04401X1)$$

Component 3 OT: **(92.86%, 96.46%)**

$$\exp(-0.07410X1) \leq \hat{R}(1) \leq \exp(-0.03603X1)$$

Aggregated Component to System DT:

(99.9860%, 99.9905%)

$$\text{Lower Bound} = 1 - (1 - 0.9481)^3 = 0.999860$$

$$\text{Upper Bound} = 1 - (1 - 0.9544)^3 = 0.999905$$

Aggregated Component to System OT:

(99.9778%, 99.9936%)

$$\text{Lower Bound} = 1 - (1 - 0.9394)^3 = 0.999778$$

$$\text{Upper Bound} = 1 - (1 - 0.9599)^3 = 0.999936$$

Component Level Aggregated to System DT:

(99.9841%, 99.9919%)

$$\begin{aligned} \text{Lower Bound} &= 1 - (1 - LB_1)(1 - LB_2)(1 - LB_3) \\ &= 1 - (1 - 0.9493)(1 - 0.9420)(1 - 0.9460) = 0.999841 \end{aligned}$$

$$\begin{aligned} \text{Upper Bound} &= 1 - (1 - UB_1)(1 - UB_2)(1 - UB_3) \\ &= 1 - (1 - 0.9599)(1 - 0.9533)(1 - 0.9569) = 0.999919 \end{aligned}$$

Component Level Aggregated to System OT:

(99.9688%, 99.9965%)

$$\begin{aligned} \text{Lower Bound} &= 1 - (1 - LB_1)(1 - LB_2)(1 - LB_3) \\ &= 1 - (1 - 0.9425)(1 - 0.9240)(1 - 0.9286) = 0.999688 \end{aligned}$$

$$\begin{aligned} \text{Upper Bound} &= 1 - (1 - UB_1)(1 - UB_2)(1 - UB_3) \\ &= 1 - (1 - 0.9744)(1 - 0.9613)(1 - 0.9646) = 0.999965. \end{aligned}$$

The Bayesian Exponential Method.

Bayesian Exponential Prior.

For the component aggregated data, from Table F1:

$$\hat{E}(\lambda) = \bar{\lambda} = \mathbf{0.04993} \text{ and } \hat{V}(\lambda) = s_{\lambda^2} = \mathbf{0.00002}.$$

These yielded the parameter estimates

$$\alpha = \left(\frac{0.04993^2}{0.00002} \right) = \mathbf{139.59} \text{ and } \beta = \left(\frac{0.04993}{0.00002} \right) = \mathbf{2795.66}.$$

For Component 1 data, from Table F3:

$$\hat{E}(\lambda) = \bar{\lambda} = \mathbf{0.04645} \text{ and } \hat{V}(\lambda) = s_{\lambda^2} = \mathbf{0.00002}.$$

These yielded the parameter estimates

$$\alpha = \left(\frac{0.04645^2}{0.00002} \right) = \mathbf{92.19} \text{ and } \beta = \left(\frac{0.04645}{0.00002} \right) = \mathbf{1984.67}.$$

For Component 2 data, from Table F5:

$$\widehat{E}(\lambda) = \overline{\lambda} = \mathbf{0.05372} \text{ and } \widehat{V}(\lambda) = s_{\lambda}^2 = \mathbf{0.00018}.$$

These yielded the parameter estimates

$$\alpha = \left(\frac{0.05372^2}{0.00018} \right) = \mathbf{16.15} \text{ and } \beta = \left(\frac{0.05372}{0.00018} \right) = \mathbf{300.71}.$$

For Component 3 data, from Table F7:

$$\widehat{E}(\lambda) = \overline{\lambda} = \mathbf{0.04962} \text{ and } \widehat{V}(\lambda) = s_{\lambda}^2 = \mathbf{0.00012}.$$

These yielded the parameter estimates

$$\alpha = \left(\frac{0.04962^2}{0.00012} \right) = \mathbf{19.97} \text{ and } \beta = \left(\frac{0.04962}{0.00012} \right) = \mathbf{402.48}.$$

Bayesian Exponential Posterior Analysis.

$$\text{Aggregated Component: } \hat{\lambda} = \left(\frac{37+139.59}{719.88+2795.66} \right) = \mathbf{0.05023}.$$

$$\text{Component 1: } \hat{\lambda} = \left(\frac{10+92.19}{239.96+1984.67} \right) = \mathbf{0.04594}.$$

$$\text{Component 2: } \hat{\lambda} = \left(\frac{14+16.15}{239.96+300.71} \right) = \mathbf{0.05576}.$$

$$\text{Component 3: } \hat{\lambda} = \left(\frac{13+19.97}{239.96+402.48} \right) = \mathbf{0.05132}.$$

The 80% two-sided probability intervals (TBPI) are

Aggregated Component:

$$\left(\frac{\chi_{0.2/2}^2(2 \times 37 + 2 \times 139.59)}{2(719.88 + 2795.66)}, \frac{\chi_{1-0.2/2}^2(2 \times 37 + 2 \times 139.59)}{2(719.88 + 2795.66)} \right)$$

$$= \left(\frac{319.41}{7031.08}, \frac{387.45}{7031.08} \right) = \mathbf{(0.04543, 0.05511)}.$$

$$\begin{aligned} \text{Component 1: } & \left(\frac{\chi_{0.2/2}^2(2 \times 10 + 2 \times 92.19)}{2(239.96 + 1984.67)}, \frac{\chi_{1-0.2/2}^2(2 \times 10 + 2 \times 92.19)}{2(239.96 + 1984.67)} \right) \\ & = \left(\frac{178.58}{4449.26}, \frac{230.28}{4449.26} \right) = \mathbf{(0.04014, 0.05176)}. \end{aligned}$$

$$\begin{aligned} \text{Component 2: } & \left(\frac{\chi_{0.2/2}^2(2 \times 14 + 2 \times 16.15)}{2(239.96 + 300.71)}, \frac{\chi_{1-0.2/2}^2(2 \times 14 + 2 \times 16.15)}{2(239.96 + 300.71)} \right) \\ & = \left(\frac{46.46}{1081.34}, \frac{74.4}{1081.34} \right) = \mathbf{(0.04296, 0.06880)}. \end{aligned}$$

$$\begin{aligned} \text{Component 3: } & \left(\frac{\chi_{0.2/2}^2(2 \times 13 + 2 \times 19.97)}{2(239.96 + 402.48)}, \frac{\chi_{1-0.2/2}^2(2 \times 13 + 2 \times 19.97)}{2(239.96 + 402.48)} \right) \\ & = \left(\frac{50.88}{1284.88}, \frac{79.97}{1284.88} \right) = \mathbf{(0.03960, 0.06224)}. \end{aligned}$$

The Bayesian estimators of $R(t)$ for $t = 1$ hour are

Aggregated Component: $\hat{R}(t) = \mathbf{95.10\%}$

$$\hat{R}(t) = \left(\frac{\left(\frac{719.88}{2795.66} \right) + 1}{\left(\frac{719.88}{2795.66} \right) + \left(\frac{1}{2795.66} \right) + 1} \right)^{139.59+37}$$

Component 1: $\hat{R}(t) = \mathbf{95.51\%}$

$$\hat{R}(t) = \left(\frac{\left(\frac{239.96}{1984.67} \right) + 1}{\left(\frac{239.96}{1984.67} \right) + \left(\frac{1}{1984.67} \right) + 1} \right)^{92.19+10}$$

Component 2: $\hat{R}(t) = \mathbf{94.58\%}$

$$\hat{R}(t) = \left(\frac{\left(\frac{239.96}{300.71} \right) + 1}{\left(\frac{239.96}{300.71} \right) + \left(\frac{1}{300.71} \right) + 1} \right)^{16.15+14}$$

Component 3: $\hat{R}(t) = \mathbf{95.00\%}$

$$\hat{R}(t) = \left(\frac{\left(\frac{239.96}{402.48} \right) + 1}{\left(\frac{239.96}{402.48} \right) + \left(\frac{1}{402.48} \right) + 1} \right)^{19.97+13}$$

Aggregated Component to System: $\hat{R}(t) = 99.9882\%$

$$\hat{R}(t) = 1 - (1 - R_c)^3 = 1 - (1 - 95.10\%)^3 = 0.999882$$

Component Level Aggregated to System: $\hat{R}(t) = 99.9878\%$

$$\hat{R}(t) = 1 - (1 - 0.9551)(1 - 0.9458)(1 - 0.9500)$$

The 80% two-sided probability intervals (TBPI) are

Aggregated Component: **$(94.64\% \leq \hat{R}(1) \leq 95.56\%)$**

$$\exp(-0.05511 \times 1) \leq \hat{R}(1) \leq \exp(-0.04543 \times 1).$$

Component 1: **$(94.96\% \leq \hat{R}(1) \leq 96.07\%)$**

$$\exp(-0.05176 \times 1) \leq \hat{R}(1) \leq \exp(-0.04014 \times 1).$$

Component 2: **$(93.35\% \leq \hat{R}(1) \leq 95.80\%)$**

$$\exp(-0.06880 \times 1) \leq \hat{R}(1) \leq \exp(-0.04296 \times 1).$$

Component 3: **$(93.97\% \leq \hat{R}(1) \leq 96.12\%)$**

$$\exp(-0.06224 \times 1) \leq \hat{R}(1) \leq \exp(-0.03960 \times 1).$$

Aggregated Component to System: **$(99.9846\%, 99.9913\%)$**

$$\text{Lower Bound} = 1 - (1 - 0.9464)^3 = 0.999846$$

$$\text{Upper Bound} = 1 - (1 - 0.9556)^3 = 0.999913$$

Component Level Aggregated to System:

$(99.9798\%, 99.9936\%)$

$$\text{Lower Bound} = 1 - (1 - LB_1)(1 - LB_2)(1 - LB_3)$$

$$= 1 - (1 - 0.9496)(1 - 0.9335)(1 - 0.9397) = 0.999798$$

$$\text{Upper Bound} = 1 - (1 - UB_1)(1 - UB_2)(1 - UB_3)$$

$$= 1 - (1 - 0.9607)(1 - 0.9580)(1 - 0.9612) = 0.999936.$$

Appendix G. Simulated Data For Parallel System With

Different Independent Components.

DT Data Run #1

Time	Component Failure	Time	Component Failure	Time	Component Failure
6.03	C1	177.73	C2	328.02	C1
9.36	C1	180.72	C2	328.93	C1
21.91	C1	184.44	C1	337.22	C2
24.08	C3	187.58	C1	351.00	C1
28.79	C1	189.41	C1	354.85	C2
33.23	C2	189.68	C1	365.39	C2
33.42	C2	201.89	C1	367.84	C2
38.45	C2	209.57	C2	371.18	C1
41.87	C3	226.86	C1	376.72	C1
43.37	C1	240.59	C1	377.86	C1
49.15	C3	243.74	C1	383.68	C2
65.41	C2	249.69	C2	384.25	C2
74.71	C2	251.30	C1	386.30	C3
76.85	C2	261.09	C1	390.86	C2
102.23	C1	262.25	C1	397.32	C2
102.40	C1	264.60	C1	404.24	C1
102.70	C1	267.10	C1	405.30	C1
106.51	C1	274.40	C2	418.69	C1
108.57	C1	276.84	C1	424.05	C1
110.18	C1	279.60	C3	427.08	C1
133.90	C1	284.25	C1	429.30	C1
136.90	C1	284.26	C2	434.15	C1
140.04	C3	285.73	C1	437.05	C1
151.32	C1	290.06	C3	437.24	C2
156.12	C2	296.62	C1	443.94	C1
161.19	C3	301.54	C1	444.49	C2
165.34	C1	304.56	C2	446.56	C1
171.86	C1	305.03	C3	448.34	C1
172.97	C2	306.18	C3	457.56	C1
173.20	C1	322.17	C2	488.03	C1
177.59	C1	323.68	C2		

DT Data Run #2

Time	Component Failure	Time	Component Failure	Time	Component Failure
3.90	C2	196.14	C3	340.60	C1
7.23	C3	201.56	C1	365.29	C1
7.61	C2	203.70	C2	366.46	C2
7.82	C1	213.24	C1	369.83	C1
14.65	C1	217.15	C1	381.72	C1
17.42	C1	219.19	C2	389.02	C1
18.91	C2	236.49	C2	398.17	C1
22.44	C2	242.73	C1	399.58	C2
34.50	C1	243.28	C1	407.08	C2
46.64	C1	249.64	C2	409.67	C2
46.79	C1	253.23	C2	413.71	C1
52.25	C1	256.43	C3	416.37	C1
56.58	C1	257.41	C1	416.42	C2
61.16	C1	275.39	C1	417.14	C1
84.34	C1	277.64	C1	418.10	C1
85.06	C1	283.34	C2	424.77	C1
85.10	C2	283.80	C1	432.10	C2
95.32	C3	296.04	C2	439.16	C1
112.01	C1	296.34	C1	440.17	C2
115.58	C3	298.74	C2	443.43	C1
118.78	C1	299.96	C2	447.82	C2
124.60	C2	302.78	C1	452.04	C1
130.93	C1	306.89	C1	454.71	C2
140.08	C3	309.74	C1	458.89	C2
156.14	C1	322.13	C1	468.41	C1
164.75	C2	323.67	C1	471.86	C1
166.15	C2	324.09	C1	481.86	C2
166.29	C1	326.37	C1	482.41	C1
177.87	C1	328.53	C1	498.15	C1
186.36	C2	328.59	C2		
191.28	C3	330.33	C3		

DT Data Run #3

Time	Component Failure	Time	Component Failure
2.47	C2	274.65	C1
3.89	C2	279.05	C3
6.14	C3	283.69	C1
12.44	C1	288.17	C1
19.74	C2	289.58	C1
24.37	C2	292.01	C1
30.43	C2	296.44	C2
37.23	C2	306.05	C1
37.56	C1	311.49	C2
52.17	C1	313.14	C3
54.17	C1	330.60	C3
57.07	C1	330.62	C1
58.99	C3	332.40	C3
64.06	C2	343.77	C1
78.26	C1	347.58	C1
78.47	C1	356.96	C1
79.43	C1	363.66	C3
100.52	C1	370.35	C1
100.66	C1	371.06	C2
107.65	C1	387.09	C3
108.07	C1	392.95	C1
112.62	C1	394.49	C1
117.15	C1	394.51	C1
125.21	C2	395.85	C1
148.12	C2	401.96	C2
149.47	C2	416.91	C1
152.94	C1	419.24	C1
153.45	C2	421.87	C2
155.09	C1	425.12	C1
155.69	C2	427.82	C1
183.32	C1	434.34	C1
190.35	C2	435.53	C2
203.84	C3	441.33	C1
228.08	C1	446.11	C1
228.64	C3	455.95	C1
231.15	C3	464.17	C2
236.29	C2	474.43	C2
236.76	C3	481.60	C1
245.00	C1	488.36	C2
269.60	C2	498.39	C1

DT Data Run #4

Time	Component Failure	Time	Component Failure
1.07	C2	254.11	C1
9.19	C1	259.43	C1
10.02	C2	260.10	C1
11.54	C3	266.24	C2
11.68	C2	275.53	C1
14.80	C2	280.58	C2
17.36	C2	283.27	C2
33.90	C1	288.07	C2
43.33	C1	288.67	C1
50.04	C3	296.32	C2
50.40	C2	297.52	C2
51.32	C1	300.02	C3
51.73	C1	300.80	C1
59.03	C1	302.24	C3
67.39	C3	309.28	C1
85.41	C3	323.91	C1
89.71	C1	336.46	C3
95.02	C1	357.20	C2
106.10	C1	381.58	C2
108.87	C2	389.83	C3
110.09	C1	406.69	C2
113.31	C1	411.97	C1
123.58	C1	415.72	C1
126.61	C2	417.64	C1
130.21	C2	435.36	C1
141.32	C1	438.08	C1
144.89	C2	441.96	C1
157.24	C1	445.27	C1
161.29	C2	448.37	C3
164.69	C1	452.14	C2
208.39	C1	454.89	C1
208.97	C1	463.03	C2
215.92	C1	467.94	C1
216.81	C1	496.10	C2
234.96	C2	496.55	C2
239.33	C2		

DT Data Run #5

Time	Component Failure	Time	Component Failure	Time	Component Failure
0.17	C1	136.39	C1	311.20	C1
11.94	C3	139.84	C1	313.51	C1
12.00	C2	141.80	C1	319.84	C2
15.77	C2	151.48	C1	319.96	C2
17.13	C1	156.22	C1	320.31	C1
33.77	C2	159.43	C1	328.99	C2
34.84	C1	166.95	C2	334.68	C2
37.31	C1	167.06	C1	336.05	C1
43.99	C1	168.03	C1	339.66	C2
47.63	C1	168.91	C1	344.45	C2
50.27	C2	176.16	C1	345.21	C2
52.59	C1	180.09	C1	353.47	C1
53.61	C3	181.48	C1	364.79	C3
59.96	C2	198.49	C1	368.50	C1
62.89	C1	202.00	C2	371.28	C2
67.11	C2	211.50	C1	384.22	C2
71.75	C1	216.34	C1	400.70	C2
83.43	C1	226.76	C2	404.40	C1
90.72	C1	235.59	C1	409.07	C2
91.24	C1	236.75	C2	414.83	C1
93.38	C1	239.91	C1	417.70	C1
103.97	C1	247.21	C1	425.99	C3
104.68	C1	256.07	C2	426.65	C1
110.20	C2	257.26	C1	442.94	C1
110.35	C3	257.53	C1	449.73	C1
111.37	C2	258.07	C2	451.98	C1
112.83	C1	264.20	C2	451.99	C1
114.60	C1	271.22	C2	452.57	C1
117.70	C2	273.63	C1	474.32	C3
121.11	C1	281.84	C2	479.76	C1
123.04	C3	282.96	C3	479.79	C2
126.10	C2	283.17	C2	480.37	C1
131.07	C2	283.24	C1	491.62	C1
133.41	C3	310.37	C1	496.36	C1

OT Data Runs #1 and #2

OT Data Run #1		OT Data Run #2	
Time	Component Failure	Time	Component Failure
7.82	C1	5.58	C1
8.11	C3	12.85	C2
8.27	C2	14.31	C3
22.23	C2	27.61	C2
22.99	C2	27.78	C1
24.08	C3	32.47	C1
27.60	C1	36.89	C1
36.39	C1	47.72	C2
36.81	C1	60.70	C1
46.17	C2	62.34	C2
51.33	C1	70.50	C2
51.35	C2	74.63	C2
66.15	C2	85.33	C1
66.33	C2	86.59	C2
70.65	C1	89.67	C1
72.85	C1	91.98	C2
80.58	C1	105.08	C3
85.55	C2	109.31	C3
96.34	C1	113.13	C1
96.94	C3	113.29	C3
100.62	C1		
106.24	C1		
108.08	C2		
112.81	C1		
122.22	C1		

**Appendix H. Calculation For Parallel System Reliability
With Different Independent Components.**

Consider a system composed of $k = 3$ different components in parallel configuration. The time to failure of each component is assumed to be exponentially distributed. Let $\lambda_1 = 0.1$, $\lambda_2 = 0.05$, and $\lambda_3 = 0.025$ be the respective constant failure rates (failure per hour) of each component.

For the true system, using a mission time, t of one hour, the reliability of components 1, 2, and 3 are

$$R_1 = \exp(-0.100) = \mathbf{90.48\%}$$

$$R_2 = \exp(-0.050) = \mathbf{95.12\%}$$

$$R_3 = \exp(-0.025) = \mathbf{97.53\%}.$$

The reliability of the system can be calculated as

$$R_s = 1 - (1 - R_1)(1 - R_2)(1 - R_3)$$

$$= 1 - (1 - 0.9048)(1 - 0.9512)(1 - 0.9753) = \mathbf{99.9885\%}.$$

Using a computer program called RAPTOR, which is developed by AFOTEC, to simulate the true system, the following data are obtained (to review the simulated data, see Appendix G):

Table H1: Component 1 DT Data

Run i	T_i Hours	X_i Failures	$\hat{\lambda}_i = X_i/T_i$
1	488.03	55	0.11270
2	498.15	53	0.10639
3	498.39	44	0.08828
4	496.55	36	0.07250
5	496.36	60	0.12088

Table H2: Component 1 OT Data

Run i	T _i Hours	X _i Failures	$\hat{\lambda}_i = X_i/T_i$
1	122.22	13	0.10637
2	113.29	8	0.07062

Table H3: Component 2 DT Data

Run i	T _i Hours	X _i Failures	$\hat{\lambda}_i = X_i/T_i$
1	488.03	27	0.05532
2	498.15	30	0.06022
3	498.39	24	0.04816
4	496.55	26	0.05236
5	496.36	33	0.06648

Table H4: Component 2 OT Data

Run i	T _i Hours	X _i Failures	$\hat{\lambda}_i = X_i/T_i$
1	122.22	9	0.07364
2	113.29	8	0.07062

Table H5: Component 3 DT Data

Run i	T _i Hours	X _i Failures	$\hat{\lambda}_i = X_i/T_i$
1	488.03	10	0.02049
2	498.15	8	0.01606
3	498.39	12	0.02408
4	496.55	9	0.01813
5	496.36	9	0.01813

Table H6: Component 3 OT Data

Run i	T _i Hours	X _i Failures	$\hat{\lambda}_i = X_i/T_i$
1	122.22	3	0.02455
2	113.29	4	0.03531

The Classical Exponential Method.

Assuming the time to failure of each component has the exponential distribution, point estimates for the failure rate λ and 80% confidence intervals about λ will be computed.

$$\text{Component 1 DT: } \hat{\lambda} = \left(\frac{f_1}{T_1} \right) = \left(\frac{248}{2477.48} \right) = \mathbf{0.10010}$$

$$\text{Component 1 OT: } \hat{\lambda} = \left(\frac{f_2}{T_2} \right) = \left(\frac{21}{235.51} \right) = \mathbf{0.08917}$$

$$\text{Component 2 DT: } \hat{\lambda} = \left(\frac{f_3}{T_3} \right) = \left(\frac{140}{2477.48} \right) = \mathbf{0.05651}$$

$$\text{Component 2 OT: } \hat{\lambda} = \left(\frac{f_4}{T_4} \right) = \left(\frac{17}{235.51} \right) = \mathbf{0.07218}$$

$$\text{Component 3 DT: } \hat{\lambda} = \left(\frac{f_5}{T_5} \right) = \left(\frac{48}{2477.48} \right) = \mathbf{0.01938}$$

$$\text{Component 3 OT: } \hat{\lambda} = \left(\frac{f_6}{T_6} \right) = \left(\frac{7}{235.51} \right) = \mathbf{0.02972}$$

where $f_1 = 248$ is the number of failures and $T_1 = 2477.48$ is the total test time from Table H1, $f_2 = 21$ and $T_2 = 235.51$ from Table H2, $f_3 = 140$ and $T_3 = 2477.48$ from Table H3, $f_4 = 17$ and $T_4 = 235.51$ from Table H4, $f_5 = 48$ and $T_5 = 2477.48$ from Table H5, $f_6 = 7$ and $T_6 = 235.51$ from Table H6.

The 80% two-sided confidence intervals (TCI) are

Component 1 DT: (0.09205, 0.10833)

$$\left(\frac{\chi_{0.2/2}^2(2 \times 248)}{2 \times 2477.48}, \frac{\chi_{1-0.2/2}^2(2 \times 248)}{2 \times 2477.48} \right) = \left(\frac{456.09}{4954.96}, \frac{536.77}{4954.96} \right)$$

Component 1 OT: (0.06532, 0.11484)

$$\left(\frac{\chi_{0.2/2}^2(2 \times 21)}{2 \times 235.51}, \frac{\chi_{1-0.2/2}^2(2 \times 21)}{2 \times 235.51} \right) = \left(\frac{30.77}{471.02}, \frac{54.09}{471.02} \right)$$

Component 2 DT: (0.05048, 0.06271)

$$\left(\frac{\chi_{0.2/2}^2(2 \times 140)}{2 \times 2477.48}, \frac{\chi_{1-0.2/2}^2(2 \times 140)}{2 \times 2477.48} \right) = \left(\frac{250.13}{4954.96}, \frac{310.72}{4954.96} \right)$$

Component 2 OT: (0.05085, 0.09533)

$$\left(\frac{\chi_{0.2/2}^2(2 \times 17)}{2 \times 235.51}, \frac{\chi_{1-0.2/2}^2(2 \times 17)}{2 \times 235.51} \right) = \left(\frac{23.95}{471.02}, \frac{44.9}{471.02} \right)$$

Component 3 DT: (0.01589, 0.02303)

$$\left(\frac{\chi_{0.2/2}^2(2 \times 48)}{2 \times 2477.48}, \frac{\chi_{1-0.2/2}^2(2 \times 48)}{2 \times 2477.48} \right) = \left(\frac{78.73}{4954.96}, \frac{114.13}{4954.96} \right)$$

Component 3 OT: (0.01654, 0.04472)

$$\left(\frac{\chi_{0.2/2}^2(2 \times 7)}{2 \times 235.51}, \frac{\chi_{1-0.2/2}^2(2 \times 7)}{2 \times 235.51} \right) = \left(\frac{7.79}{471.02}, \frac{21.06}{471.02} \right)$$

The reliability estimators of $R(t)$ for $t = 1$ hour are

Component 1 DT: $\widehat{R}_1(t) = \exp(-0.10010 \times 1) = 90.48\%$

Component 1 OT: $\widehat{R}_1(t) = \exp(-0.08917 \times 1) = 91.47\%$

Component 2 DT: $\widehat{R}_2(t) = \exp(-0.05651 \times 1) = 94.51\%$

Component 2 OT: $\widehat{R}_2(t) = \exp(-0.07218 \times 1) = 93.04\%$

Component 3 DT: $\widehat{R}_3(t) = \exp(-0.01938 \times 1) = 98.08\%$

Component 3 OT: $\widehat{R}_3(t) = \exp(-0.02972 \times 1) = 97.07\%$

Component Level Aggregated to System DT: $\widehat{R}(t) = 99.99\%$

$$\widehat{R}(t) = 1 - (1 - 0.9048)(1 - 0.9451)(1 - 0.9808)$$

Component Level Aggregated to System OT:

$$\begin{aligned} \widehat{R}(t) &= 1 - (1 - 0.9147)(1 - 0.9304)(1 - 0.9707) \\ &= 99.9826\%. \end{aligned}$$

The 80% two-sided confidence intervals (TCI) are

Component 1 DT: (89.73%, 91.21%)

$$\exp(-0.10833 \times 1) \leq \widehat{R}(1) \leq \exp(-0.09205 \times 1)$$

Component 1 OT: (89.15%, 93.68%)

$$\exp(-0.11484 \times 1) \leq \widehat{R}(1) \leq \exp(-0.06532 \times 1)$$

Component 2 DT: (93.92%, 95.08%)

$$\exp(-0.06271X1) \leq \hat{R}(1) \leq \exp(-0.05048X1)$$

Component 2 OT: (90.91%, 95.04%)

$$\exp(-0.09533X1) \leq \hat{R}(1) \leq \exp(-0.05085X1)$$

Component 3 DT: (97.72%, 98.42%)

$$\exp(-0.02303X1) \leq \hat{R}(1) \leq \exp(-0.01589X1)$$

Component 3 OT: (95.63%, 98.36%)

$$\exp(-0.04472X1) \leq \hat{R}(1) \leq \exp(-0.01654X1)$$

Component Level Aggregated to System DT:

(99.9858%, 99.9932%)

$$\text{Lower Bound} = 1 - (1 - 0.8973)(1 - 0.9392)(1 - 0.9772)$$

$$\text{Upper Bound} = 1 - (1 - 0.9121)(1 - 0.9508)(1 - 0.9842)$$

Component Level Aggregated to System OT:

(99.9569%, 99.9949%)

$$\text{Lower Bound} = 1 - (1 - 0.8915)(1 - 0.9091)(1 - 0.9563)$$

$$\text{Upper Bound} = 1 - (1 - 0.9368)(1 - 0.9504)(1 - 0.9836).$$

The Bayesian Exponential Method.

Bayesian Exponential Prior.

For Component 1 data, from Table H1:

$$\hat{E}(\lambda) = \bar{\lambda} = 0.10015 \text{ and } \hat{V}(\lambda) = s_{\lambda}^2 = 0.00038.$$

These yielded the parameter estimates

$$\alpha = \left(\frac{0.10015^2}{0.00038} \right) = 26.40 \text{ and } \beta = \left(\frac{0.10015}{0.00038} \right) = 263.55.$$

For Component 2 data, from Table H3:

$$\hat{E}(\lambda) = \bar{\lambda} = \mathbf{0.05651} \text{ and } \hat{V}(\lambda) = s_{\lambda}^2 = \mathbf{0.00005}.$$

These yielded the parameter estimates

$$\alpha = \left(\frac{0.05651^2}{0.00005} \right) = \mathbf{63.87} \text{ and } \beta = \left(\frac{0.05651}{0.00005} \right) = \mathbf{1130.2}.$$

For Component 3 data, from Table H5:

$$\hat{E}(\lambda) = \bar{\lambda} = \mathbf{0.01938} \text{ and } \hat{V}(\lambda) = s_{\lambda}^2 = \mathbf{0.00001}.$$

These yielded the parameter estimates

$$\alpha = \left(\frac{0.01938^2}{0.00001} \right) = \mathbf{37.56} \text{ and } \beta = \left(\frac{0.01938}{0.00001} \right) = \mathbf{1938}.$$

Bayesian Exponential Posterior Analysis.

$$\text{Component 1: } \hat{\lambda} = \left(\frac{21+26.4}{235.51+263.55} \right) = \mathbf{0.09498}.$$

$$\text{Component 2: } \hat{\lambda} = \left(\frac{17+63.87}{235.51+1130.2} \right) = \mathbf{0.05922}.$$

$$\text{Component 3: } \hat{\lambda} = \left(\frac{7+37.56}{235.51+1938} \right) = \mathbf{0.02050}.$$

The 80% two-sided probability intervals (TBPI) are

$$\text{Component 1: } \left(\frac{\chi_{0.2/2}^2(2 \times 21 + 2 \times 26.4)}{2(235.51 + 263.55)}, \frac{\chi_{1-0.2/2}^2(2 \times 21 + 2 \times 26.4)}{2(235.51 + 263.55)} \right)$$

$$= \left(\frac{76.91}{998.12}, \frac{111.94}{998.12} \right) = \mathbf{(0.07706, 0.11216)}.$$

$$\text{Component 2: } \left(\frac{\chi_{0.2/2}^2(2 \times 17 + 2 \times 63.87)}{2(235.51 + 1130.2)}, \frac{\chi_{1-0.2/2}^2(2 \times 17 + 2 \times 63.87)}{2(235.51 + 1130.2)} \right)$$

$$= \left(\frac{138.47}{2731.42}, \frac{184.38}{2731.42} \right) = \mathbf{(0.05070, 0.06750)}.$$

$$\text{Component 3: } \left(\frac{\chi_{0.2/2}^2(2 \times 7 + 2 \times 37.56)}{2(235.51 + 1938)}, \frac{\chi_{1-0.2/2}^2(2 \times 7 + 2 \times 37.56)}{2(235.51 + 1938)} \right)$$

$$= \left(\frac{72.39}{4347.02}, \frac{106.47}{4347.02} \right) = \mathbf{(0.01665, 0.02449)}.$$

The Bayesian estimators of $R(t)$ for $t = 1$ hour are

Component 1: $\hat{R}(t) = 90.95\%$

$$\hat{R}(t) = \left(\frac{\left(\frac{235.51}{263.55} \right) + 1}{\left(\frac{235.51}{263.55} \right) + \left(\frac{1}{263.55} \right) + 1} \right)^{26.4+21}$$

Component 2: $\hat{R}(t) = 94.25\%$

$$\hat{R}(t) = \left(\frac{\left(\frac{235.51}{1130.2} \right) + 1}{\left(\frac{235.51}{1130.2} \right) + \left(\frac{1}{1130.2} \right) + 1} \right)^{63.87+17}$$

Component 3: $\hat{R}(t) = 97.97\%$

$$\hat{R}(t) = \left(\frac{\left(\frac{235.51}{1938} \right) + 1}{\left(\frac{235.51}{1938} \right) + \left(\frac{1}{1938} \right) + 1} \right)^{37.56+7}$$

Component Level Aggregated to System: $\hat{R}(t) = 99.9894\%$

$$\hat{R}(t) = 1 - (1 - 0.9095)(1 - 0.9425)(1 - 0.9797).$$

The 80% two-sided probability intervals (TBPI) are

Component 1: $(89.39\% \leq \hat{R}(1) \leq 92.58\%)$

$$\exp(-0.11216 \times 1) \leq \hat{R}(1) \leq \exp(-0.07706 \times 1).$$

Component 2: $(93.47\% \leq \hat{R}(1) \leq 95.06\%)$

$$\exp(-0.06750 \times 1) \leq \hat{R}(1) \leq \exp(-0.05070 \times 1).$$

Component 3: $(97.58\% \leq \hat{R}(1) \leq 98.35\%)$

$$\exp(-0.02449 \times 1) \leq \hat{R}(1) \leq \exp(-0.01665 \times 1).$$

Component Level Aggregated to System: $(99.9832\%, 99.994\%)$

$$\text{Lower Bound} = 1 - (1 - 0.8939)(1 - 0.9347)(1 - 0.9758)$$

$$\text{Upper Bound} = 1 - (1 - 0.9258)(1 - 0.9506)(1 - 0.9835).$$

**Appendix I. Simulated Data For A Bridge System With
Independent And Identical Components.**

DT Data Run #1

Time	Fail	Time	Fail	Time	Fail	Time	Fail
6.66	C5	139.79	C2	260.39	C3	384.83	C5
12.04	C3	140.33	C2	264.41	C2	386.05	C2
12.06	C1	142.74	C3	266.69	C2	391.94	C4
20.96	C1	149.49	C5	270.53	C1	394.66	C3
25.80	C3	158.44	C1	271.10	C1	401.82	C4
25.99	C3	164.77	C2	271.47	C3	403.74	C1
29.44	C4	167.16	C4	275.73	C5	407.75	C3
31.02	C3	171.06	C2	277.59	C4	407.96	C4
31.76	C5	182.30	C4	277.71	C1	420.43	C3
33.23	C2	185.90	C1	279.82	C1	424.30	C4
34.66	C3	188.21	C1	282.18	C5	428.60	C3
43.96	C3	189.61	C5	292.90	C5	430.08	C5
46.09	C3	192.67	C3	298.96	C5	433.07	C3
50.10	C1	192.92	C1	303.40	C5	437.72	C5
50.43	C1	194.60	C5	306.61	C1	441.39	C1
51.04	C1	195.77	C2	312.40	C1	445.33	C3
56.41	C4	201.01	C2	313.09	C5	447.24	C2
58.66	C1	201.87	C4	317.51	C4	447.41	C5
60.53	C4	202.79	C1	319.45	C2	450.87	C5
61.88	C1	203.96	C2	320.35	C5	464.21	C4
67.88	C1	209.42	C5	322.77	C4	466.10	C3
78.68	C2	211.44	C2	323.89	C5	466.32	C3
89.25	C2	212.15	C3	326.18	C1	468.33	C5
96.73	C1	219.26	C5	332.49	C3	485.42	C4
107.96	C4	219.83	C5	336.40	C3	486.10	C4
113.57	C1	222.17	C4	341.22	C4	490.04	C1
117.30	C2	223.68	C4	354.70	C1	490.37	C1
119.98	C2	224.57	C1	360.58	C3	491.49	C4
124.74	C2	226.39	C1	361.05	C1	492.86	C2
125.37	C3	229.76	C3	365.46	C4	494.52	C3
126.60	C1	237.22	C4	372.13	C3	495.03	C4
129.59	C1	247.40	C3	380.68	C1	495.29	C3
133.52	C2	257.93	C3	381.88	C3	495.50	C3
139.08	C3	259.89	C5	383.66	C4	498.06	C3
						499.37	C3

DT Data Run #2

Time	Component Failure	Time	Component Failure	Time	Component Failure
4.36	C2	131.29	C2	344.14	C5
4.51	C1	134.68	C3	345.53	C1
6.77	C4	146.27	C4	351.96	C2
7.22	C1	147.67	C5	353.05	C3
8.43	C1	150.14	C5	359.08	C2
12.33	C3	151.84	C1	368.48	C1
12.69	C5	157.55	C4	372.65	C5
18.40	C5	162.11	C5	372.68	C2
19.66	C4	165.01	C4	379.50	C4
20.53	C3	165.05	C1	383.91	C3
21.38	C3	166.16	C3	387.88	C2
22.73	C4	167.51	C1	390.46	C5
25.95	C3	168.83	C2	398.52	C5
27.04	C4	173.24	C5	409.40	C1
29.43	C2	174.81	C2	413.68	C3
37.07	C1	176.95	C2	416.10	C2
43.19	C5	195.96	C1	416.42	C4
50.09	C3	196.87	C4	418.07	C1
52.26	C5	198.22	C4	418.60	C5
64.90	C4	199.84	C3	424.48	C1
76.03	C5	202.09	C1	426.34	C4
79.50	C4	215.72	C5	427.27	C2
83.22	C3	228.84	C5	433.87	C3
86.45	C1	228.97	C3	436.88	C5
89.05	C1	229.03	C1	437.44	C3
90.71	C3	229.58	C1	439.65	C2
94.35	C5	230.82	C1	442.77	C2
95.79	C1	241.36	C1	443.83	C2
95.87	C5	271.43	C1	443.93	C3
96.05	C3	274.81	C5	446.19	C4
97.80	C5	282.22	C1	451.99	C4
109.38	C3	282.96	C1	456.79	C4
110.57	C4	287.80	C4	457.42	C4
111.47	C1	289.59	C4	467.93	C3
117.46	C3	290.93	C5	473.89	C1
117.48	C2	308.02	C5	477.44	C3
119.12	C1	310.90	C3	477.97	C5
119.12	C4	313.61	C1	481.49	C4
123.30	C4	335.89	C3	486.24	C4
124.37	C2	337.22	C4	490.82	C5
126.57	C5	337.25	C4	497.27	C5

DT Data Run #3

Time	Component Failure	Time	Component Failure	Time	Component Failure
2.96	C2	209.14	C3	363.63	C5
4.04	C2	215.08	C4	370.63	C3
5.75	C4	220.14	C3	370.89	C5
12.68	C2	221.98	C1	376.93	C2
16.24	C2	227.31	C3	380.55	C3
33.59	C1	231.32	C5	380.57	C5
37.24	C1	238.67	C2	385.48	C1
38.44	C1	240.93	C5	386.03	C4
48.96	C2	241.09	C5	387.73	C5
55.34	C3	241.26	C2	397.54	C2
68.16	C2	244.01	C4	403.20	C1
69.77	C2	244.84	C2	404.23	C1
79.30	C4	245.51	C1	408.53	C1
81.39	C1	247.55	C4	408.92	C3
85.81	C4	262.06	C5	410.34	C3
86.40	C2	263.28	C5	411.08	C5
88.56	C4	267.35	C3	412.12	C2
90.60	C5	268.55	C4	412.25	C5
97.14	C5	268.64	C5	418.46	C2
97.65	C3	273.88	C5	418.58	C5
103.04	C4	275.38	C1	422.00	C2
103.96	C3	275.81	C2	426.65	C3
137.42	C1	277.54	C4	429.11	C4
140.36	C5	278.22	C1	429.70	C1
147.29	C1	278.93	C2	430.40	C2
148.69	C3	279.98	C3	431.59	C5
149.72	C2	286.78	C2	434.30	C4
149.80	C3	291.53	C5	434.67	C1
152.45	C3	300.53	C3	438.59	C1
153.95	C1	301.34	C5	441.21	C4
163.35	C4	310.11	C2	450.70	C4
164.02	C1	326.98	C3	457.12	C4
166.31	C3	327.32	C3	457.21	C3
173.01	C2	329.63	C2	457.94	C1
178.30	C2	333.29	C3	459.89	C1
186.75	C3	336.91	C5	461.63	C1
192.89	C1	340.68	C5	466.28	C2
196.39	C1	350.62	C4	472.38	C4
198.78	C1	354.13	C3	474.14	C2
201.63	C5	358.68	C5	475.16	C4
203.02	C1	363.56	C2	476.14	C1
				492.26	C3

DT Data Run #4

Time	Component Failure	Time	Component Failure	Time	Component Failure
9.99	C4	179.08	C5	341.36	C3
14.23	C5	182.59	C2	349.36	C5
14.24	C5	184.75	C3	351.70	C1
23.47	C3	186.46	C4	357.70	C4
24.44	C5	192.17	C3	366.46	C4
25.32	C1	192.27	C2	371.11	C2
28.88	C5	196.37	C1	382.98	C3
30.50	C1	209.78	C3	384.09	C5
32.08	C3	218.92	C2	390.94	C5
32.86	C4	222.44	C2	391.66	C1
38.49	C2	224.64	C5	394.03	C3
40.20	C4	226.48	C1	397.11	C2
41.35	C4	227.60	C4	397.88	C2
41.83	C4	231.42	C1	400.00	C4
42.61	C2	233.02	C5	406.06	C3
44.88	C1	243.07	C1	419.63	C5
47.21	C2	243.08	C1	419.94	C3
59.71	C1	247.54	C3	425.22	C3
63.46	C5	249.07	C3	428.58	C1
64.38	C1	259.52	C3	432.91	C2
80.78	C2	260.99	C1	434.18	C1
84.46	C2	262.70	C5	435.45	C5
91.49	C4	276.34	C4	436.52	C1
99.18	C2	286.19	C2	436.58	C5
103.74	C2	286.85	C2	447.31	C4
108.38	C4	291.65	C1	448.34	C3
109.49	C1	292.46	C2	452.06	C1
109.73	C2	292.62	C3	453.11	C1
112.68	C5	292.92	C4	457.29	C4
118.74	C1	298.54	C5	457.46	C4
124.77	C5	298.93	C5	462.20	C2
129.61	C1	300.74	C1	462.78	C4
130.63	C2	302.56	C2	464.59	C5
131.63	C2	302.72	C2	478.08	C5
140.39	C3	303.75	C2	480.56	C5
146.45	C5	311.16	C1	486.78	C1
151.21	C3	319.74	C3	487.90	C3
158.31	C4	320.36	C2	491.72	C4
163.06	C5	322.40	C3	493.38	C3
166.08	C4	326.34	C4	493.77	C4
176.23	C2	327.79	C5	498.61	C5
177.60	C1	337.68	C5		

DT Data Run #5

Time	Fail	Time	Fail	Time	Fail	Time	Fail
0.66	C1	100.21	C5	230.54	C1	361.06	C3
2.46	C1	101.18	C3	237.16	C3	362.47	C4
9.64	C3	107.58	C1	250.45	C3	362.49	C3
11.34	C2	108.34	C3	259.24	C5	366.30	C2
15.24	C5	110.96	C1	261.30	C3	372.01	C3
15.76	C2	113.82	C5	269.72	C2	379.40	C3
16.99	C1	116.24	C5	271.63	C3	387.26	C3
18.92	C4	136.24	C4	283.72	C1	387.52	C2
19.35	C1	136.89	C1	284.86	C3	394.09	C1
23.96	C1	137.38	C3	287.11	C3	398.00	C2
27.71	C5	143.38	C2	290.48	C1	402.96	C2
32.46	C3	144.89	C2	293.61	C1	408.64	C1
39.19	C4	146.83	C2	298.03	C5	412.57	C4
41.84	C4	148.11	C2	298.94	C4	413.73	C3
42.73	C3	148.17	C4	303.67	C5	418.63	C4
46.14	C1	150.91	C2	304.29	C3	424.71	C2
51.54	C1	153.87	C4	304.86	C2	429.67	C4
53.34	C4	157.99	C1	312.43	C3	429.92	C2
54.58	C5	159.91	C5	312.70	C5	432.24	C3
58.58	C2	165.49	C3	318.07	C1	432.71	C4
59.05	C1	166.48	C5	330.95	C2	449.61	C5
62.97	C4	170.87	C4	339.34	C4	457.91	C5
63.89	C3	177.89	C3	343.35	C4	462.61	C5
70.26	C3	181.20	C3	344.37	C5	462.62	C3
70.93	C2	182.23	C2	345.96	C3	465.37	C1
83.10	C1	184.71	C3	350.78	C5	469.82	C5
84.92	C4	199.68	C1	351.37	C4	485.61	C5
88.38	C3	201.85	C3	351.86	C1	491.02	C4
89.47	C2	214.69	C4	352.32	C4	492.67	C2
89.86	C1	218.13	C4	354.27	C4	496.42	C5
98.77	C2	221.07	C2	354.44	C1	499.68	C5
98.82	C3	223.39	C1	358.72	C3		
99.94	C4	225.80	C5	360.41	C1		

OT Data Runs #1 and #2

OT Data Run #1		OT Data Run #2	
Time	Component Failure	Time	Component Failure
4.06	C3	0.87	C2
8.27	C2	8.85	C3
12.04	C3	9.38	C1
12.80	C3	15.50	C2
15.64	C1	17.54	C1
22.23	C2	19.63	C2
35.98	C3	28.30	C2
36.82	C3	29.50	C1
39.57	C5	33.68	C2
39.80	C2	40.37	C4
44.76	C5	42.48	C4
52.07	C1	44.47	C4
52.25	C1	47.61	C5
59.55	C5	58.12	C3
62.05	C4	69.32	C5
63.94	C5	76.44	C1
65.86	C3	76.90	C5
71.46	C1	79.17	C3
77.51	C4	87.49	C5
78.45	C2	90.62	C5
80.02	C1	98.37	C3
88.39	C3	103.75	C1
89.69	C2	116.16	C3
93.16	C1	120.20	C4
95.46	C5	120.63	C3
104.13	C1	120.82	C1
108.31	C5	122.92	C1
108.52	C2		
114.59	C4		
123.77	C3		

Appendix J. Calculation For A Bridge System Reliability

With Independent And Identical Components.

Consider a system composed of 5 independent and identical components given in Figure 1 (page 30). The time to failure of each component is assumed to be exponentially distributed. Let $\lambda = 0.05$ failure per hour be the respective constant failure rates of each component.

For the true system, using a mission time, t of one hour, the reliability of components 1, 2, 3, 4, and 5 are

$$R_c = R_1 = R_2 = R_3 = R_4 = R_5 = \exp(-0.05) = \mathbf{95.12\%}.$$

The reliability of the system can be calculated as

$$R_s = R_1R_4 + R_2R_5 + R_1R_3R_5 + R_2R_3R_4 - R_1R_2R_3R_4 - R_1R_2R_3R_5 - R_1R_2R_4R_5 - R_1R_3R_4R_5 - R_2R_3R_4R_5 + 2R_1R_2R_3R_4R_5 = \mathbf{99.50\%}.$$

Using a computer program called RAPTOR, which is developed by AFOTEC, to simulate the true system, the following data are obtained (to review the simulated data, see Appendix I):

Table J1: Aggregated Components DT Data

Run i	T _i Hours	X _i Failures	$\widehat{\lambda}_i = X_i/T_i$
1	2,496.85	136	0.05447
2	2,486.35	123	0.04947
3	2,461.3	124	0.05038
4	2,493.05	125	0.05014
5	2,498.4	130	0.05203

Table J2: Aggregated Components OT Data

Run i	T _i Hours	X _i Failures	$\widehat{\lambda}_i = X_i/T_i$
1	618.85	30	0.04848
2	604.1	26	0.04304

Table J3: Component 1 DT Data

Run i	T_i Hours	X_i Failures	$\hat{\lambda}_i = X_i/T_i$
1	499.37	32	0.06408
2	497.27	28	0.05631
3	492.26	27	0.05485
4	498.61	26	0.05215
5	499.68	27	0.05404

Table J4: Component 1 OT Data

Run i	T_i Hours	X_i Failures	$\hat{\lambda}_i = X_i/T_i$
1	123.77	7	0.05656
2	120.82	6	0.04966

Table J5: Component 2 DT Data

Run i	T_i Hours	X_i Failures	$\hat{\lambda}_i = X_i/T_i$
1	499.37	21	0.04205
2	497.27	17	0.03419
3	492.26	28	0.05688
4	498.61	27	0.05415
5	499.68	23	0.04603

Table J6: Component 2 OT Data

Run i	T_i Hours	X_i Failures	$\hat{\lambda}_i = X_i/T_i$
1	123.77	6	0.04848
2	120.82	5	0.04138

Table J7: Component 3 DT Data

Run i	T_i Hours	X_i Failures	$\hat{\lambda}_i = X_i/T_i$
1	499.37	35	0.07009
2	497.27	24	0.04826
3	492.26	25	0.05079
4	498.61	22	0.04412
5	499.68	33	0.06604

Table J8: Component 3 OT Data

Run i	T_i Hours	X_i Failures	$\hat{\lambda}_i = X_i/T_i$
1	123.77	8	0.06464
2	120.82	6	0.04966

Table J9: Component 4 DT Data

Run i	T _i Hours	X _i Failures	$\hat{\lambda}_i = X_i/T_i$
1	499.37	25	0.05006
2	497.27	27	0.05430
3	492.26	20	0.04063
4	498.61	23	0.04613
5	499.68	25	0.05003

Table J10: Component 4 OT Data

Run i	T _i Hours	X _i Failures	$\hat{\lambda}_i = X_i/T_i$
1	123.77	3	0.02424
2	120.82	4	0.03311

Table J11: Component 5 DT Data

Run i	T _i Hours	X _i Failures	$\hat{\lambda}_i = X_i/T_i$
1	499.37	23	0.04606
2	497.27	27	0.05430
3	492.26	24	0.04876
4	498.61	27	0.05415
5	499.68	22	0.04403

Table J12: Component 5 OT Data

Run i	T _i Hours	X _i Failures	$\hat{\lambda}_i = X_i/T_i$
1	123.77	6	0.04848
2	120.82	5	0.04138

The Classical Exponential Method.

Assuming the time to failure of each component has the exponential distribution, point estimates for the failure rate λ and 80% confidence intervals about λ will be computed.

$$\text{Component Aggregated DT: } \hat{\lambda} = \left(\frac{638}{12435.95} \right) = \mathbf{0.05130}$$

$$\text{Component Aggregated OT: } \hat{\lambda} = \left(\frac{56}{1222.95} \right) = \mathbf{0.04579}$$

$$\text{Component 1 DT: } \hat{\lambda} = \left(\frac{f_3}{T_3} \right) = \left(\frac{140}{2487.19} \right) = \mathbf{0.05629}$$

$$\text{Component 1 OT: } \hat{\lambda} = \left(\frac{f_4}{T_4} \right) = \left(\frac{13}{244.59} \right) = \mathbf{0.05315}$$

$$\text{Component 2 DT: } \hat{\lambda} = \left(\frac{f_5}{T_5} \right) = \left(\frac{116}{2487.19} \right) = \mathbf{0.04664}$$

$$\text{Component 2 OT: } \hat{\lambda} = \left(\frac{f_6}{T_6} \right) = \left(\frac{11}{244.59} \right) = \mathbf{0.04497}$$

$$\text{Component 3 DT: } \hat{\lambda} = \left(\frac{f_7}{T_7} \right) = \left(\frac{139}{2487.19} \right) = \mathbf{0.05589}$$

$$\text{Component 3 OT: } \hat{\lambda} = \left(\frac{f_8}{T_8} \right) = \left(\frac{14}{244.59} \right) = \mathbf{0.05724}$$

$$\text{Component 4 DT: } \hat{\lambda} = \left(\frac{f_9}{T_9} \right) = \left(\frac{120}{2487.19} \right) = \mathbf{0.04825}$$

$$\text{Component 4 OT: } \hat{\lambda} = \left(\frac{f_{10}}{T_{10}} \right) = \left(\frac{7}{244.59} \right) = \mathbf{0.02862}$$

$$\text{Component 5 DT: } \hat{\lambda} = \left(\frac{f_{11}}{T_{11}} \right) = \left(\frac{123}{2487.19} \right) = \mathbf{0.04945}$$

$$\text{Component 5 OT: } \hat{\lambda} = \left(\frac{f_{12}}{T_{12}} \right) = \left(\frac{11}{244.59} \right) = \mathbf{0.04497}$$

where $f_1 = 638$ is the number of failures and $T_1 = 12435.95$ is the total test time from Table J1, $f_2 = 56$ and $T_2 = 1222.95$ from Table J2, $f_3 = 140$ and $T_3 = 2487.19$ from Table J3, $f_4 = 13$ and $T_4 = 244.59$ from Table J4, $f_5 = 116$ and $T_5 = 2487.19$ from Table J5, $f_6 = 11$ and $T_6 = 244.59$ from Table J6, $f_7 = 139$ and $T_7 = 2487.19$ from Table J7, $f_8 = 14$ and $T_8 = 244.59$ from Table J8, $f_9 = 120$ and $T_9 = 2487.19$ from Table J9, $f_{10} = 7$ and $T_{10} = 244.59$ from Table J10, $f_{11} = 123$ and T_{11}

= 2487.19 from Table J11, $f_{12} = 11$ and $T_{12} = 244.59$ from Table J12.

The 80% two-sided confidence intervals (TCI) are

Component Aggregated DT: (0.04872, 0.05392)

$$\left(\frac{\chi^2_{0.2/2}(2 \times 638)}{2 \times 12435.95}, \frac{\chi^2_{1-0.2/2}(2 \times 638)}{2 \times 12435.95} \right) = \left(\frac{1211.7}{24871.9}, \frac{1341.15}{24871.9} \right)$$

Component Aggregated OT: (0.03815, 0.05379)

$$\left(\frac{\chi^2_{0.2/2}(2 \times 56)}{2 \times 1222.95}, \frac{\chi^2_{1-0.2/2}(2 \times 56)}{2 \times 1222.95} \right) = \left(\frac{93.3}{2445.9}, \frac{131.56}{2445.9} \right)$$

Component 1 DT: (0.05028, 0.06247)

$$\left(\frac{\chi^2_{0.2/2}(2 \times 140)}{2 \times 2487.19}, \frac{\chi^2_{1-0.2/2}(2 \times 140)}{2 \times 2487.19} \right) = \left(\frac{250.13}{4974.38}, \frac{310.72}{4974.38} \right)$$

Component 1 OT: (0.03535, 0.07270)

$$\left(\frac{\chi^2_{0.2/2}(2 \times 13)}{2 \times 244.59}, \frac{\chi^2_{1-0.2/2}(2 \times 13)}{2 \times 244.59} \right) = \left(\frac{17.29}{489.18}, \frac{35.56}{489.18} \right)$$

Component 2 DT: (0.04118, 0.05227)

$$\left(\frac{\chi^2_{0.2/2}(2 \times 116)}{2 \times 2487.19}, \frac{\chi^2_{1-0.2/2}(2 \times 116)}{2 \times 2487.19} \right) = \left(\frac{204.86}{4974.38}, \frac{260}{4974.38} \right)$$

Component 2 OT: (0.02870, 0.06299)

$$\left(\frac{\chi^2_{0.2/2}(2 \times 11)}{2 \times 244.59}, \frac{\chi^2_{1-0.2/2}(2 \times 11)}{2 \times 244.59} \right) = \left(\frac{14.04}{489.18}, \frac{30.81}{489.18} \right)$$

Component 3 DT: (0.04990, 0.06204)

$$\left(\frac{\chi^2_{0.2/2}(2 \times 139)}{2 \times 2487.19}, \frac{\chi^2_{1-0.2/2}(2 \times 139)}{2 \times 2487.19} \right) = \left(\frac{248.24}{4974.38}, \frac{308.61}{4974.38} \right)$$

Component 3 OT: (0.03872, 0.07751)

$$\left(\frac{\chi_{0.2/2}^2(2 \times 14)}{2 \times 244.59}, \frac{\chi_{1-0.2/2}^2(2 \times 14)}{2 \times 244.59} \right) = \left(\frac{18.94}{489.18}, \frac{37.92}{489.18} \right)$$

Component 4 DT: (0.04270, 0.05397)

$$\left(\frac{\chi_{0.2/2}^2(2 \times 120)}{2 \times 2487.19}, \frac{\chi_{1-0.2/2}^2(2 \times 120)}{2 \times 2487.19} \right) = \left(\frac{212.39}{4974.38}, \frac{268.47}{4974.38} \right)$$

Component 4 OT: (0.01592, 0.04306)

$$\left(\frac{\chi_{0.2/2}^2(2 \times 7)}{2 \times 244.59}, \frac{\chi_{1-0.2/2}^2(2 \times 7)}{2 \times 244.59} \right) = \left(\frac{7.79}{489.18}, \frac{21.06}{489.18} \right)$$

Component 5 DT: (0.04383, 0.05525)

$$\left(\frac{\chi_{0.2/2}^2(2 \times 123)}{2 \times 2487.19}, \frac{\chi_{1-0.2/2}^2(2 \times 123)}{2 \times 2487.19} \right) = \left(\frac{218.04}{4974.38}, \frac{274.82}{4974.38} \right)$$

Component 5 OT: (0.02870, 0.06912)

$$\left(\frac{\chi_{0.2/2}^2(2 \times 11)}{2 \times 244.59}, \frac{\chi_{1-0.2/2}^2(2 \times 11)}{2 \times 244.59} \right) = \left(\frac{14.04}{489.18}, \frac{33.81}{489.18} \right)$$

The reliability estimators of $R(t)$ for $t = 1$ hour are

Component Aggregated DT:

$$\widehat{R}_c(t) = \exp(-0.05130 \times 1) = \mathbf{95.00\%}$$

Component Aggregated OT:

$$\widehat{R}_c(t) = \exp(-0.04579 \times 1) = \mathbf{95.52\%}$$

$$\text{Component 1 DT: } \widehat{R}_1(t) = \exp(-0.05629 \times 1) = \mathbf{94.53\%}$$

$$\text{Component 1 OT: } \widehat{R}_1(t) = \exp(-0.05315 \times 1) = \mathbf{94.82\%}$$

$$\text{Component 2 DT: } \widehat{R}_2(t) = \exp(-0.04664 \times 1) = \mathbf{95.44\%}$$

$$\text{Component 2 OT: } \widehat{R}_2(t) = \exp(-0.04497 \times 1) = \mathbf{95.60\%}$$

$$\text{Component 3 DT: } \widehat{R}_3(t) = \exp(-0.05589 \times 1) = \mathbf{94.57\%}$$

Component 3 OT: $\widehat{R}_3(t) = \exp(-0.05724 \times 1) = 94.44\%$

Component 4 DT: $\widehat{R}_4(t) = \exp(-0.04825 \times 1) = 95.29\%$

Component 4 OT: $\widehat{R}_4(t) = \exp(-0.02862 \times 1) = 97.18\%$

Component 5 DT: $\widehat{R}_5(t) = \exp(-0.04945 \times 1) = 95.18\%$

Component 5 OT: $\widehat{R}_5(t) = \exp(-0.04497 \times 1) = 95.60\%$

Substitute the appropriate values into $\widehat{R}(t) = R_1R_4 + R_2R_5 + R_1R_3R_5 + R_2R_3R_4 - R_1R_2R_3R_4 - R_1R_2R_3R_5 - R_1R_2R_4R_5 - R_1R_3R_4R_5 - R_2R_3R_4R_5 + 2R_1R_2R_3R_4R_5$ to obtain the following:

Aggregated Component to System DT: $\widehat{R}(t) = 99.48\%$

Aggregated Component to System OT: $\widehat{R}(t) = 99.58\%$

Component Level Aggregated to System DT: $\widehat{R}(t) = 99.50\%$

Component Level Aggregated to System OT: $\widehat{R}(t) = 99.63\%$

The 80% two-sided confidence intervals (TCI) are

Aggregated Component DT: **(94.75%, 95.25%)**

$\exp(-0.05392 \times 1) \leq \widehat{R}(1) \leq \exp(-0.04872 \times 1)$

Aggregated Component OT: **(94.76%, 96.26%)**

$\exp(-0.05379 \times 1) \leq \widehat{R}(1) \leq \exp(-0.03815 \times 1)$

Component 1 DT: **(93.95%, 95.10%)**

$\exp(-0.06247 \times 1) \leq \widehat{R}(1) \leq \exp(-0.05028 \times 1)$

Component 1 OT: **(92.99%, 96.53%)**

$\exp(-0.07270 \times 1) \leq \widehat{R}(1) \leq \exp(-0.03535 \times 1)$

Component 2 DT: **(94.91%, 95.97%)**

$$\exp(-0.05227X1) \leq \hat{R}(1) \leq \exp(-0.04118X1)$$

Component 2 OT: (93.90%, 97.17%)

$$\exp(-0.06299X1) \leq \hat{R}(1) \leq \exp(-0.02870X1)$$

Component 3 DT: (93.99%, 95.13%)

$$\exp(-0.06204X1) \leq \hat{R}(1) \leq \exp(-0.04990X1)$$

Component 3 OT: (92.54%, 96.20%)

$$\exp(-0.07751X1) \leq \hat{R}(1) \leq \exp(-0.03872X1)$$

Component 4 DT: (94.75%, 95.82%)

$$\exp(-0.05397X1) \leq \hat{R}(1) \leq \exp(-0.04270X1)$$

Component 4 OT: (95.79%, 98.42%)

$$\exp(-0.04306X1) \leq \hat{R}(1) \leq \exp(-0.01592X1)$$

Component 5 DT: (94.63%, 95.71%)

$$\exp(-0.05525X1) \leq \hat{R}(1) \leq \exp(-0.04383X1)$$

Component 5 OT: (93.32%, 97.17%)

$$\exp(-0.06912X1) \leq \hat{R}(1) \leq \exp(-0.02870X1)$$

Substitute the appropriate values into $\hat{R}(t) = R_1R_4 + R_2R_5 + R_1R_3R_5 + R_2R_3R_4 - R_1R_2R_3R_4 - R_1R_2R_3R_5 - R_1R_2R_4R_5 - R_1R_3R_4R_5 - R_2R_3R_4R_5 + 2R_1R_2R_3R_4R_5$ to obtain the following:

Aggregated Component to System DT: (99.42%, 99.53%)

Aggregated Component to System OT: (99.43%, 99.71%)

Component Level Aggregated to System DT:

(99.38%, 99.61%)

Component Level Aggregated to System OT:

(99.24%, 99.85%) .

The Bayesian Exponential Method.

Bayesian Exponential Prior.

For the component aggregated data, from Table J1:

$$\hat{E}(\lambda) = \bar{\lambda} = \mathbf{0.051298} \text{ and } \hat{V}(\lambda) = s_{\lambda}^2 = \mathbf{0.000004}.$$

These yielded the parameter estimates

$$\alpha = \left(\frac{0.051298^2}{0.000004} \right) = \mathbf{657.87} \text{ and } \beta = \left(\frac{0.051298}{0.000004} \right) = \mathbf{12824.5}.$$

For Component 1 data, from Table J3:

$$\hat{E}(\lambda) = \bar{\lambda} = \mathbf{0.05628} \text{ and } \hat{V}(\lambda) = s_{\lambda}^2 = \mathbf{0.00002}.$$

These yielded the parameter estimates

$$\alpha = \left(\frac{0.05628^2}{0.00002} \right) = \mathbf{150.85} \text{ and } \beta = \left(\frac{0.05628}{0.00002} \right) = \mathbf{2680.14}.$$

For Component 2 data, from Table J5:

$$\hat{E}(\lambda) = \bar{\lambda} = \mathbf{0.04666} \text{ and } \hat{V}(\lambda) = s_{\lambda}^2 = \mathbf{0.00008}.$$

These yielded the parameter estimates

$$\alpha = \left(\frac{0.04666^2}{0.00008} \right) = \mathbf{25.92} \text{ and } \beta = \left(\frac{0.04666}{0.00008} \right) = \mathbf{555.48}.$$

For Component 3 data, from Table J7:

$$\hat{E}(\lambda) = \bar{\lambda} = \mathbf{0.05586} \text{ and } \hat{V}(\lambda) = s_{\lambda}^2 = \mathbf{0.00013}.$$

These yielded the parameter estimates

$$\alpha = \left(\frac{0.05586^2}{0.00013} \right) = \mathbf{23.64} \text{ and } \beta = \left(\frac{0.05586}{0.00013} \right) = \mathbf{423.19}.$$

For Component 4 data, from Table J9:

$$\hat{E}(\lambda) = \bar{\lambda} = \mathbf{0.04823} \text{ and } \hat{V}(\lambda) = s_{\lambda}^2 = \mathbf{0.00003}.$$

These yielded the parameter estimates

$$\alpha = \left(\frac{0.04823^2}{0.00003} \right) = \mathbf{89.47} \text{ and } \beta = \left(\frac{0.04823}{0.00003} \right) = \mathbf{1855}.$$

For Component 5 data, from Table J11:

$$\hat{E}(\lambda) = \bar{\lambda} = \mathbf{0.04946} \text{ and } \hat{V}(\lambda) = s_{\lambda}^2 = \mathbf{0.00002}.$$

These yielded the parameter estimates

$$\alpha = \left(\frac{0.04946^2}{0.00002} \right) = \mathbf{111.19} \text{ and } \beta = \left(\frac{0.04946}{0.00002} \right) = \mathbf{2248.09}.$$

Bayesian Exponential Posterior Analysis.

$$\text{Aggregated Component: } \hat{\lambda} = \left(\frac{56+657.87}{1222.95+12824.5} \right) = \mathbf{0.05082}.$$

$$\text{Component 1: } \hat{\lambda} = \left(\frac{13+150.85}{244.59+2680.14} \right) = \mathbf{0.05602}.$$

$$\text{Component 2: } \hat{\lambda} = \left(\frac{11+25.92}{244.59+555.48} \right) = \mathbf{0.04614}.$$

$$\text{Component 3: } \hat{\lambda} = \left(\frac{14+23.64}{244.59+423.19} \right) = \mathbf{0.05637}.$$

$$\text{Component 4: } \hat{\lambda} = \left(\frac{7+89.47}{244.59+1855} \right) = \mathbf{0.04595}.$$

$$\text{Component 5: } \hat{\lambda} = \left(\frac{11+111.19}{244.59+2248.09} \right) = \mathbf{0.04902}.$$

The 80% two-sided probability intervals (TBPI) are

Aggregated Component:

$$\left(\frac{\chi_{0.2/2}^2(2 \times 56 + 2 \times 657.87)}{2(1222.95 + 12824.5)}, \frac{\chi_{1-0.2/2}^2(2 \times 56 + 2 \times 657.87)}{2(1222.95 + 12824.5)} \right)$$

$$= \left(\frac{1359.7}{28094.9}, \frac{1496.64}{28094.9} \right) = \mathbf{(0.04840, 0.05327)}.$$

$$\text{Component 1: } \left(\frac{\chi_{0.2/2}^2(2 \times 13 + 2 \times 150.85)}{2(244.59 + 2680.14)}, \frac{\chi_{1-0.2/2}^2(2 \times 13 + 2 \times 150.85)}{2(244.59 + 2680.14)} \right)$$

$$= \left(\frac{294.68}{5849.46}, \frac{360.17}{5849.46} \right) = (0.05038, 0.06157).$$

$$\text{Component 2: } \left(\frac{\chi_{0.2/2}^2(2 \times 11 + 2 \times 25.92)}{2(244.59 + 555.48)}, \frac{\chi_{1-0.2/2}^2(2 \times 11 + 2 \times 25.92)}{2(244.59 + 555.48)} \right)$$

$$= \left(\frac{58.01}{1600.14}, \frac{88.85}{1600.14} \right) = (0.03625, 0.05553).$$

$$\text{Component 3: } \left(\frac{\chi_{0.2/2}^2(2 \times 14 + 2 \times 23.64)}{2(244.59 + 423.19)}, \frac{\chi_{1-0.2/2}^2(2 \times 14 + 2 \times 23.64)}{2(244.59 + 423.19)} \right)$$

$$= \left(\frac{59.8}{1335.56}, \frac{91.06}{1335.56} \right) = (0.04477, 0.06818).$$

$$\text{Component 4: } \left(\frac{\chi_{0.2/2}^2(2 \times 7 + 2 \times 89.47)}{2(244.59 + 1855)}, \frac{\chi_{1-0.2/2}^2(2 \times 7 + 2 \times 89.47)}{2(244.59 + 1855)} \right)$$

$$= \left(\frac{167.35}{4199.18}, \frac{217.5}{4199.18} \right) = (0.03985, 0.05180).$$

$$\text{Component 5: } \left(\frac{\chi_{0.2/2}^2(2 \times 11 + 2 \times 111.19)}{2(244.59 + 2248.09)}, \frac{\chi_{1-0.2/2}^2(2 \times 11 + 2 \times 111.19)}{2(244.59 + 2248.09)} \right)$$

$$= \left(\frac{216.15}{4985.36}, \frac{272.7}{4985.36} \right) = (0.04336, 0.05470).$$

The Bayesian estimators of $R(t)$ for $t = 1$ hour are

Aggregated Component: $\hat{R}(t) = 95.05\%$

$$\hat{R}(t) = \left(\frac{\left(\frac{1222.95}{12824.5} \right) + 1}{\left(\frac{1222.95}{12824.5} \right) + \left(\frac{1}{12824.5} \right) + 1} \right)^{657.87+56}$$

Component 1: $\hat{R}(t) = 94.55\%$

$$\hat{R}(t) = \left(\frac{\left(\frac{244.59}{2680.14} \right) + 1}{\left(\frac{244.59}{2680.14} \right) + \left(\frac{1}{2680.14} \right) + 1} \right)^{150.85+13}$$

Component 2: $\hat{R}(t) = 95.49\%$

$$\hat{R}(t) = \left(\frac{\left(\frac{244.59}{555.48} \right) + 1}{\left(\frac{244.59}{555.48} \right) + \left(\frac{1}{555.48} \right) + 1} \right)^{25.92+11}$$

Component 3: $\hat{R}(t) = 94.52\%$

$$\hat{R}(t) = \left(\frac{\left(\frac{244.59}{423.19} \right) + 1}{\left(\frac{244.59}{423.19} \right) + \left(\frac{1}{423.19} \right) + 1} \right)^{23.64+14}$$

Component 4: $\hat{R}(t) = 95.51\%$

$$\hat{R}(t) = \left(\frac{\left(\frac{244.59}{1855} \right) + 1}{\left(\frac{244.59}{1855} \right) + \left(\frac{1}{1855} \right) + 1} \right)^{89.47+7}$$

Component 5: $\hat{R}(t) = 95.22\%$

$$\hat{R}(t) = \left(\frac{\left(\frac{244.59}{2248.09} \right) + 1}{\left(\frac{244.59}{2248.09} \right) + \left(\frac{1}{2248.09} \right) + 1} \right)^{111.19+11}$$

Substitute the appropriate values into $\hat{R}(t) = R_1R_4 + R_2R_5 + R_1R_3R_5 + R_2R_3R_4 - R_1R_2R_3R_4 - R_1R_2R_3R_5 - R_1R_2R_4R_5 - R_1R_3R_4R_5 - R_2R_3R_4R_5 + 2R_1R_2R_3R_4R_5$ to obtain the following:

Aggregated Component to System: $\hat{R}(t) = 99.49\%$

Component Level Aggregated to System: $\hat{R}(t) = 99.52\%$.

The 80% two-sided probability intervals (TBPI) are

Aggregated Component: $(94.81\% \leq \hat{R}(1) \leq 95.28\%)$

$\exp(-0.05327 \times 1) \leq \hat{R}(1) \leq \exp(-0.04840 \times 1)$.

Component 1: $(94.03\% \leq \hat{R}(1) \leq 95.09\%)$

$$\exp(-0.06157X1) \leq \hat{R}(1) \leq \exp(-0.05038X1).$$

Component 2: (94.60% ≤ $\hat{R}(1)$ ≤ 96.44%)

$$\exp(-0.05553X1) \leq \hat{R}(1) \leq \exp(-0.03625X1).$$

Component 3: (93.41% ≤ $\hat{R}(1)$ ≤ 95.62%)

$$\exp(-0.06818X1) \leq \hat{R}(1) \leq \exp(-0.04477X1).$$

Component 4: (94.95% ≤ $\hat{R}(1)$ ≤ 96.09%)

$$\exp(-0.05180X1) \leq \hat{R}(1) \leq \exp(-0.03985X1).$$

Component 5: (94.68% ≤ $\hat{R}(1)$ ≤ 95.76%)

$$\exp(-0.05470X1) \leq \hat{R}(1) \leq \exp(-0.04336X1).$$

Substitute the appropriate values into $\hat{R}(t) = R_1R_4 + R_2R_5 + R_1R_3R_5 + R_2R_3R_4 - R_1R_2R_3R_4 - R_1R_2R_3R_5 - R_1R_2R_4R_5 - R_1R_3R_4R_5 - R_2R_3R_4R_5 + 2R_1R_2R_3R_4R_5$ to obtain the following:

Aggregated Component to System: (99.44%, 99.54%)

Component Level Aggregated to System: (99.38%, 99.65%).

Appendix K. Simulated Data For A Bridge System With

Different Independent Components.

DT Data Run #1

Time	Fail	Time	Fail	Time	Fail	Time	Fail
6.03	C1	134.00	C1	246.06	C4	368.17	C5
16.66	C5	135.49	C1	250.50	C3	370.91	C4
18.06	C3	149.91	C1	253.23	C3	378.72	C4
18.58	C1	153.05	C1	261.18	C1	382.44	C1
31.40	C3	153.22	C3	267.25	C5	382.74	C3
31.68	C3	154.03	C3	270.00	C1	392.26	C3
33.15	C1	154.61	C2	273.13	C4	394.56	C1
33.23	C2	154.88	C1	275.26	C1	404.38	C1
36.88	C2	168.43	C4	278.04	C4	409.59	C3
39.22	C3	174.94	C1	283.04	C2	413.48	C1
46.64	C1	178.08	C1	283.18	C1	418.01	C2
51.07	C5	185.65	C1	285.32	C2	424.22	C3
51.28	C1	190.69	C3	285.89	C2	425.01	C1
56.41	C5	198.01	C1	292.50	C2	427.08	C4
57.23	C5	199.16	C1	300.20	C4	430.78	C2
58.75	C5	201.52	C1	309.56	C1	436.65	C3
58.89	C4	204.01	C1	313.11	C4	439.46	C5
67.14	C4	204.54	C2	317.32	C4	440.66	C2
73.58	C4	213.75	C1	319.43	C3	447.63	C1
77.80	C5	214.40	C2	329.52	C1	453.97	C1
90.92	C1	219.63	C2	332.56	C1	454.82	C5
92.80	C5	220.05	C3	334.78	C1	456.28	C3
105.35	C1	221.16	C1	335.50	C3	462.14	C1
107.39	C3	222.58	C2	339.62	C1	464.38	C1
119.24	C5	223.35	C4	344.19	C3	468.20	C1
119.37	C1	230.07	C2	346.51	C1	474.33	C1
125.88	C1	232.06	C1	349.14	C1	475.25	C5
127.22	C1	240.86	C1	353.52	C2	478.31	C2
129.60	C1	241.15	C1	355.06	C3	479.17	C1
132.66	C3	243.04	C4	357.07	C2	499.09	C2

DT Data Run #2

Time	Component Failure	Time	Component Failure	Time	Component Failure
11.59	C1	171.92	C1	285.74	C1
12.80	C1	179.22	C1	286.81	C1
17.46	C2	181.59	C2	299.44	C2
27.87	C1	188.38	C1	305.57	C2
35.62	C1	190.77	C3	306.92	C2
39.53	C1	192.12	C1	313.42	C3
40.82	C2	194.66	C3	326.50	C5
42.43	C4	195.49	C1	357.10	C3
43.35	C5	196.26	C1	369.98	C4
46.11	C5	202.67	C3	374.32	C1
58.12	C2	204.10	C1	376.79	C3
61.71	C2	205.55	C3	377.61	C3
65.11	C1	206.34	C4	379.47	C3
68.73	C4	210.76	C1	393.84	C5
71.05	C3	211.40	C5	395.29	C3
77.82	C3	212.66	C2	396.50	C2
83.59	C1	215.04	C1	411.47	C3
89.93	C1	218.49	C1	412.58	C3
91.82	C2	222.49	C4	412.62	C2
94.53	C2	229.88	C2	414.42	C2
96.31	C3	230.52	C5	415.28	C1
98.13	C3	230.85	C4	423.83	C1
102.47	C1	234.85	C1	441.89	C1
106.57	C1	247.80	C5	454.39	C1
107.42	C2	248.72	C3	458.56	C3
109.43	C1	252.85	C2	461.91	C4
110.96	C1	253.62	C1	461.98	C4
111.38	C1	255.32	C2	462.04	C2
113.66	C1	259.60	C1	469.00	C5
115.82	C1	263.34	C1	470.35	C1
116.73	C5	265.63	C3	473.91	C1
127.89	C1	268.53	C2	484.30	C3
132.20	C2	268.90	C1	489.34	C1
140.65	C4	270.99	C2	490.55	C2
141.09	C3	273.04	C4		
158.80	C4	285.02	C4		

DT Data Run #3

Time	Component Failure	Time	Component Failure	Time	Component Failure
1.41	C1	160.90	C2	375.72	C3
7.29	C3	169.54	C2	380.98	C3
8.93	C1	180.54	C1	384.56	C3
15.20	C2	182.31	C1	390.91	C3
23.93	C2	198.68	C1	391.00	C1
24.83	C2	200.50	C1	391.32	C2
38.72	C1	201.10	C1	400.48	C1
46.53	C1	220.33	C4	402.32	C2
50.34	C1	222.58	C1	404.66	C5
51.13	C2	231.44	C5	408.31	C4
59.72	C1	235.47	C5	409.49	C2
65.58	C1	243.10	C2	414.94	C1
70.22	C5	243.74	C1	416.24	C1
73.84	C4	249.61	C2	416.31	C1
77.92	C2	252.36	C2	419.10	C2
80.99	C3	258.72	C4	422.68	C2
80.99	C2	271.75	C1	426.22	C2
81.05	C3	275.02	C1	426.80	C1
83.69	C2	277.05	C5	435.44	C3
88.17	C1	287.67	C4	441.74	C1
90.51	C1	292.83	C5	442.35	C1
96.39	C1	295.49	C3	445.02	C1
103.22	C1	296.63	C1	451.33	C1
103.60	C2	310.30	C3	455.83	C1
105.91	C1	315.67	C2	457.19	C2
112.90	C1	316.78	C2	458.45	C1
116.65	C2	320.29	C3	459.87	C1
126.22	C2	324.26	C3	461.43	C1
127.22	C1	327.27	C1	463.48	C5
144.20	C3	332.30	C1	466.94	C3
145.90	C2	340.06	C2	474.84	C2
147.47	C5	345.05	C3	478.73	C3
152.86	C1	358.16	C1	488.40	C4
159.59	C3	360.81	C1	495.40	C2
159.82	C2	368.93	C2	497.97	C1

DT Data Run #4

Time	Component Failure	Time	Component Failure	Time	Component Failure
0.22	C1	147.31	C2	309.30	C2
0.67	C4	152.25	C4	320.00	C1
3.65	C1	158.28	C5	326.05	C1
16.32	C1	167.07	C5	330.21	C2
19.52	C2	169.02	C3	330.35	C5
30.00	C5	174.94	C2	331.48	C1
38.34	C1	183.38	C1	331.98	C1
40.80	C2	186.99	C1	351.89	C2
46.32	C1	187.80	C4	354.28	C1
49.32	C2	189.02	C5	361.43	C4
50.08	C3	189.94	C4	362.59	C1
55.09	C1	191.47	C1	362.72	C2
64.39	C4	199.83	C2	366.47	C1
65.60	C1	203.21	C1	376.66	C1
66.95	C1	210.58	C3	378.74	C2
67.51	C1	210.59	C3	379.84	C1
74.37	C5	214.07	C2	388.36	C3
75.71	C1	214.64	C1	397.50	C2
78.55	C1	216.86	C1	402.61	C1
86.86	C1	219.45	C1	402.89	C3
86.87	C1	222.68	C2	404.92	C2
91.08	C5	225.89	C3	423.19	C1
91.80	C1	236.74	C1	428.51	C4
92.30	C2	237.05	C2	429.30	C3
96.83	C4	240.41	C1	431.57	C2
98.62	C1	240.59	C4	434.60	C3
100.03	C1	240.99	C1	438.24	C1
106.39	C4	241.17	C2	440.71	C1
106.40	C1	241.55	C4	447.17	C3
107.29	C1	245.77	C2	450.31	C5
116.25	C3	265.82	C1	464.64	C3
118.98	C1	268.15	C1	464.67	C3
127.47	C3	271.20	C4	465.08	C1
128.22	C1	278.93	C5	465.85	C1
130.74	C3	279.34	C2	471.07	C1
131.84	C1	288.12	C5	487.62	C1
132.45	C3	292.76	C1	491.53	C3
141.67	C2	294.07	C2	495.31	C2
144.92	C2	295.04	C1		
146.64	C3	300.05	C2		

DT Data Run #5

Time	Component Failure	Time	Component Failure	Time	Component Failure
0.67	C2	166.70	C2	322.14	C2
0.82	C3	175.46	C4	323.43	C5
7.46	C2	183.11	C3	325.20	C1
9.39	C2	186.66	C2	329.85	C1
10.75	C1	192.37	C5	337.16	C2
11.20	C4	197.14	C1	338.71	C1
11.56	C3	197.29	C3	339.89	C1
13.02	C2	197.48	C5	346.68	C3
17.47	C5	205.10	C2	349.52	C5
17.70	C1	209.58	C2	358.04	C1
30.01	C5	210.49	C1	359.73	C1
37.85	C2	213.39	C3	367.10	C3
44.40	C1	223.49	C4	367.43	C5
48.36	C4	232.47	C2	373.47	C5
53.53	C1	237.11	C1	374.25	C1
53.64	C1	237.44	C1	380.21	C1
61.29	C5	239.24	C3	381.77	C2
61.65	C4	240.12	C2	385.44	C4
62.00	C1	241.92	C2	388.47	C4
63.82	C3	242.26	C1	390.76	C1
66.33	C2	244.28	C4	391.40	C1
69.25	C3	253.14	C4	392.34	C4
73.82	C1	253.66	C1	392.80	C1
73.87	C3	256.45	C2	403.73	C4
74.55	C1	258.81	C2	406.00	C3
74.64	C1	262.10	C3	408.46	C1
78.55	C3	267.99	C5	409.87	C2
78.99	C5	269.02	C3	411.74	C1
85.24	C5	275.07	C1	422.27	C2
106.44	C5	278.08	C4	437.73	C4
108.23	C1	279.08	C2	441.40	C1
109.67	C1	280.21	C1	443.16	C1
112.07	C1	283.38	C4	444.36	C4
114.33	C3	290.57	C2	462.58	C1
118.03	C1	290.79	C1	466.10	C2
122.81	C3	294.19	C4	468.55	C3
149.15	C2	295.60	C1	473.70	C3
149.39	C1	298.09	C2	474.43	C1
149.73	C3	301.78	C1	478.64	C4
150.20	C5	309.33	C3	482.65	C5
151.99	C1	312.76	C1	492.94	C4
157.39	C1	318.88	C3	498.76	C1
161.74	C1	321.82	C1		

OT Data Runs #1 and #2

OT Data Run #1		OT Data Run #2	
Time	Component Failure	Time	Component Failure
6.08	C3	22.69	C1
7.82	C1	23.44	C5
8.27	C2	27.11	C1
9.03	C2	30.16	C3
14.80	C1	34.43	C1
18.06	C3	37.63	C2
32.21	C2	38.51	C1
33.01	C1	41.76	C2
33.05	C2	42.56	C4
38.23	C2	44.49	C1
44.42	C3	50.43	C2
47.53	C1	53.33	C4
47.62	C1	57.57	C4
57.23	C1	61.55	C4
59.43	C1	67.96	C1
66.62	C3	78.81	C1
67.16	C1	89.34	C1
76.87	C2	93.12	C1
78.42	C1	104.07	C3
85.43	C2	106.78	C1
96.68	C2	116.38	C1
96.96	C1	117.95	C1
98.93	C5	119.96	C3
109.81	C2		
113.89	C3		
114.65	C1		
120.78	C2		
124.09	C4		

**Appendix L. Calculation For A Bridge System Reliability
With Different Independent Components.**

Consider a system composed of 5 different independent components given in Figure 1 (page 30). The time to failure of each component is assumed to be exponentially distributed. Let $\lambda_1 = 0.1$, $\lambda_2 = 0.05$, $\lambda_3 = 0.033$, $\lambda_4 = 0.025$, and $\lambda_5 = 0.02$ be the respective constant failure rates (failure per hour) of each component.

For the true system, using a mission time, t of one hour, the reliability of components 1, 2, 3, 4, and 5 are

$$R_1 = \exp(-0.10) = \mathbf{90.48\%}$$

$$R_2 = \exp(-0.05) = \mathbf{95.12\%}$$

$$R_3 = \exp(-0.033) = \mathbf{96.75\%}$$

$$R_4 = \exp(-0.025) = \mathbf{97.53\%}$$

$$R_5 = \exp(-0.02) = \mathbf{98.02\%}.$$

The reliability of the system can be calculated as

$$R_s = R_1R_4 + R_2R_5 + R_1R_3R_5 + R_2R_3R_4 - R_1R_2R_3R_4 - R_1R_2R_3R_5 - R_1R_2R_4R_5 - R_1R_3R_4R_5 - R_2R_3R_4R_5 + 2R_1R_2R_3R_4R_5 = \mathbf{99.48\%}.$$

Using a computer program called RAPTOR, which is developed by AFOTEC, to simulate the true system, the following data are obtained (to review the simulated data, see Appendix K):

Table L1: Component 1 DT Data

Run i	T_i Hours	X_i Failures	$\hat{\lambda}_i = X_i/T_i$
1	499.09	51	0.10219
2	490.55	41	0.08358
3	497.97	44	0.08836
4	495.31	52	0.10499
5	498.76	48	0.09624

Table L2: Component 1 OT Data

Run i	T_i Hours	X_i Failures	$\hat{\lambda}_i = X_i/T_i$
1	124.09	11	0.08865
2	119.96	12	0.10003

Table L3: Component 2 DT Data

Run i	T_i Hours	X_i Failures	$\hat{\lambda}_i = X_i/T_i$
1	499.09	19	0.03807
2	490.55	23	0.04689
3	497.97	30	0.06025
4	495.31	26	0.05249
5	498.76	25	0.05012

Table L4: Component 2 OT Data

Run i	T_i Hours	X_i Failures	$\hat{\lambda}_i = X_i/T_i$
1	124.09	10	0.08059
2	119.96	3	0.02501

Table L5: Component 3 DT Data

Run i	T_i Hours	X_i Failures	$\hat{\lambda}_i = X_i/T_i$
1	499.09	22	0.04408
2	490.55	21	0.04281
3	497.97	17	0.03414
4	495.31	18	0.03634
5	498.76	22	0.04411

Table L6: Component 3 OT Data

Run i	T_i Hours	X_i Failures	$\hat{\lambda}_i = X_i/T_i$
1	124.09	5	0.04029
2	119.96	3	0.02501

Table L7: Component 4 DT Data

Run i	T _i Hours	X _i Failures	$\hat{\lambda}_i = X_i/T_i$
1	499.09	15	0.03006
2	490.55	12	0.02446
3	497.97	6	0.01205
4	495.31	12	0.02423
5	498.76	18	0.03609

Table L8: Component 4 OT Data

Run i	T _i Hours	X _i Failures	$\hat{\lambda}_i = X_i/T_i$
1	124.09	1	0.00807
2	119.96	4	0.03334

Table L9: Component 5 DT Data

Run i	T _i Hours	X _i Failures	$\hat{\lambda}_i = X_i/T_i$
1	499.09	13	0.02605
2	490.55	9	0.01835
3	497.97	8	0.01607
4	495.31	10	0.02019
5	498.76	15	0.03008

Table L10: Component 5 OT Data

Run i	T _i Hours	X _i Failures	$\hat{\lambda}_i = X_i/T_i$
1	124.09	1	0.00806
2	119.96	1	0.00834

The Classical Exponential Method.

Assuming the time to failure of each component has the exponential distribution, point estimates for the failure rate λ and 80% confidence intervals about λ will be computed.

$$\text{Component 1 DT: } \hat{\lambda} = \left(\frac{f_1}{T_1} \right) = \left(\frac{236}{2481.68} \right) = 0.09510$$

$$\text{Component 1 OT: } \hat{\lambda} = \left(\frac{f_2}{T_2} \right) = \left(\frac{23}{244.05} \right) = 0.09424$$

$$\text{Component 2 DT: } \hat{\lambda} = \left(\frac{f_3}{T_3} \right) = \left(\frac{123}{2481.68} \right) = \mathbf{0.04956}$$

$$\text{Component 2 OT: } \hat{\lambda} = \left(\frac{f_4}{T_4} \right) = \left(\frac{13}{244.05} \right) = \mathbf{0.05327}$$

$$\text{Component 3 DT: } \hat{\lambda} = \left(\frac{f_5}{T_5} \right) = \left(\frac{100}{2481.68} \right) = \mathbf{0.04030}$$

$$\text{Component 3 OT: } \hat{\lambda} = \left(\frac{f_6}{T_6} \right) = \left(\frac{8}{244.05} \right) = \mathbf{0.03278}$$

$$\text{Component 4 DT: } \hat{\lambda} = \left(\frac{f_7}{T_7} \right) = \left(\frac{63}{2481.68} \right) = \mathbf{0.02539}$$

$$\text{Component 4 OT: } \hat{\lambda} = \left(\frac{f_8}{T_8} \right) = \left(\frac{5}{244.05} \right) = \mathbf{0.02049}$$

$$\text{Component 5 DT: } \hat{\lambda} = \left(\frac{f_9}{T_9} \right) = \left(\frac{55}{2481.68} \right) = \mathbf{0.02216}$$

$$\text{Component 5 OT: } \hat{\lambda} = \left(\frac{f_{10}}{T_{10}} \right) = \left(\frac{2}{244.59} \right) = \mathbf{0.00820}$$

where $f_1 = 236$ is the number of failures and $T_1 = 2481.68$ is the total test time from Table L1 and similarly $f_2 = 23$ and $T_2 = 244.05$ from Table L2, $f_3 = 123$ and $T_3 = 2481.68$ from Table L3, $f_4 = 13$ and $T_4 = 244.05$ from Table L4, $f_5 = 100$ and $T_5 = 2481.68$ from Table L5, $f_6 = 8$ and $T_6 = 244.05$ from Table L6, $f_7 = 63$ and $T_7 = 2481.68$ from Table L7, $f_8 = 5$ and $T_8 = 244.05$ from Table L8, $f_9 = 55$ and $T_9 = 2481.68$ from Table L9, $f_{10} = 2$ and $T_{10} = 244.05$ from Table L10.

The 80% two-sided confidence intervals (TCI) are

Component 1 DT: (0.08726, 0.10311)

$$\left(\frac{\chi_{0.2/2}^2(2 \times 236)}{2 \times 2481.68}, \frac{\chi_{1-0.2/2}^2(2 \times 236)}{2 \times 2481.68} \right) = \left(\frac{433.08}{4963.36}, \frac{511.78}{4963.36} \right)$$

Component 1 OT: (0.07010, 0.12014)

$$\left(\frac{\chi_{0.2/2}^2(2 \times 23)}{2 \times 244.05}, \frac{\chi_{1-0.2/2}^2(2 \times 23)}{2 \times 244.05} \right) = \left(\frac{34.22}{488.1}, \frac{58.64}{488.1} \right)$$

Component 2 DT: (0.04393, 0.05537)

$$\left(\frac{\chi_{0.2/2}^2(2 \times 123)}{2 \times 2481.68}, \frac{\chi_{1-0.2/2}^2(2 \times 123)}{2 \times 2481.68} \right) = \left(\frac{218.04}{4963.36}, \frac{274.82}{4963.36} \right)$$

Component 2 OT: (0.03543, 0.07286)

$$\left(\frac{\chi_{0.2/2}^2(2 \times 13)}{2 \times 244.05}, \frac{\chi_{1-0.2/2}^2(2 \times 13)}{2 \times 244.05} \right) = \left(\frac{17.29}{488.1}, \frac{35.56}{488.1} \right)$$

Component 3 DT: (0.03523, 0.04554)

$$\left(\frac{\chi_{0.2/2}^2(2 \times 100)}{2 \times 2481.68}, \frac{\chi_{1-0.2/2}^2(2 \times 100)}{2 \times 2481.68} \right) = \left(\frac{174.84}{4963.36}, \frac{226.02}{4963.36} \right)$$

Component 3 OT: (0.01908, 0.04823)

$$\left(\frac{\chi_{0.2/2}^2(2 \times 8)}{2 \times 244.05}, \frac{\chi_{1-0.2/2}^2(2 \times 8)}{2 \times 244.05} \right) = \left(\frac{9.31}{488.1}, \frac{23.54}{488.1} \right)$$

Component 4 DT: (0.02138, 0.02956)

$$\left(\frac{\chi_{0.2/2}^2(2 \times 63)}{2 \times 2481.68}, \frac{\chi_{1-0.2/2}^2(2 \times 63)}{2 \times 2481.68} \right) = \left(\frac{106.13}{4963.36}, \frac{146.72}{4963.36} \right)$$

Component 4 OT: (0.00997, 0.03275)

$$\left(\frac{\chi_{0.2/2}^2(2 \times 5)}{2 \times 244.05}, \frac{\chi_{1-0.2/2}^2(2 \times 5)}{2 \times 244.05} \right) = \left(\frac{4.87}{488.1}, \frac{15.99}{488.1} \right)$$

Component 5 DT: (0.01843, 0.02607)

$$\left(\frac{\chi_{0.2/2}^2(2 \times 55)}{2 \times 2481.68}, \frac{\chi_{1-0.2/2}^2(2 \times 55)}{2 \times 2481.68} \right) = \left(\frac{91.47}{4963.36}, \frac{129.39}{4963.36} \right)$$

Component 5 OT: (0.00218, 0.01594)

$$\left(\frac{\chi_{0.2/2}^2(2 \times 2)}{2 \times 244.05}, \frac{\chi_{1-0.2/2}^2(2 \times 2)}{2 \times 244.05} \right) = \left(\frac{1.06}{488.1}, \frac{7.78}{488.1} \right)$$

The reliability estimators of $R(t)$ for $t = 1$ hour are

Component 1 DT: $\widehat{R}_1(t) = \exp(-0.09510 \times 1) = \mathbf{90.93\%}$

Component 1 OT: $\widehat{R}_1(t) = \exp(-0.09424 \times 1) = \mathbf{91.01\%}$

Component 2 DT: $\widehat{R}_2(t) = \exp(-0.04956 \times 1) = \mathbf{95.17\%}$

Component 2 OT: $\widehat{R}_2(t) = \exp(-0.05327 \times 1) = \mathbf{94.81\%}$

Component 3 DT: $\widehat{R}_3(t) = \exp(-0.04030 \times 1) = \mathbf{96.05\%}$

Component 3 OT: $\widehat{R}_3(t) = \exp(-0.03278 \times 1) = \mathbf{96.78\%}$

Component 4 DT: $\widehat{R}_4(t) = \exp(-0.02539 \times 1) = \mathbf{97.49\%}$

Component 4 OT: $\widehat{R}_4(t) = \exp(-0.02049 \times 1) = \mathbf{97.97\%}$

Component 5 DT: $\widehat{R}_5(t) = \exp(-0.02216 \times 1) = \mathbf{97.81\%}$

Component 5 OT: $\widehat{R}_5(t) = \exp(-0.00820 \times 1) = \mathbf{99.18\%}$

Substitute the appropriate values into $\widehat{R}(t) = R_1R_4 + R_2R_5 + R_1R_3R_5 + R_2R_3R_4 - R_1R_2R_3R_4 - R_1R_2R_3R_5 - R_1R_2R_4R_5 - R_1R_3R_4R_5 - R_2R_3R_4R_5 + 2R_1R_2R_3R_4R_5$ to obtain the following:

Component Level Aggregated to System DT: $\widehat{R}(t) = \mathbf{99.50\%}$

Component Level Aggregated to System OT: $\widehat{R}(t) = \mathbf{99.51\%}$.

The 80% two-sided confidence intervals (TCI) are

Component 1 DT: **(90.20%, 91.64%)**

$\exp(-0.10311 \times 1) \leq \widehat{R}(1) \leq \exp(-0.08726 \times 1)$

Component 1 OT: **(88.68%, 93.23%)**

$\exp(-0.12014 \times 1) \leq \widehat{R}(1) \leq \exp(-0.07010 \times 1)$

Component 2 DT: **(94.61%, 95.70%)**

$$\exp(-0.05537X1) \leq \hat{R}(1) \leq \exp(-0.04393X1)$$

Component 2 OT: (92.97%, 96.52%)

$$\exp(-0.07286X1) \leq \hat{R}(1) \leq \exp(-0.03543X1)$$

Component 3 DT: (95.55%, 96.54%)

$$\exp(-0.04554X1) \leq \hat{R}(1) \leq \exp(-0.03523X1)$$

Component 3 OT: (95.29%, 98.11%)

$$\exp(-0.04823X1) \leq \hat{R}(1) \leq \exp(-0.01908X1)$$

Component 4 DT: (97.09%, 97.89%)

$$\exp(-0.02956X1) \leq \hat{R}(1) \leq \exp(-0.02138X1)$$

Component 4 OT: (96.78%, 99.01%)

$$\exp(-0.03275X1) \leq \hat{R}(1) \leq \exp(-0.00997X1)$$

Component 5 DT: (97.43%, 98.17%)

$$\exp(-0.02607X1) \leq \hat{R}(1) \leq \exp(-0.01843X1)$$

Component 5 OT: (98.42%, 99.78%)

$$\exp(-0.01594X1) \leq \hat{R}(1) \leq \exp(-0.00218X1)$$

Substitute the appropriate values into $\hat{R}(t) = R_1R_4 + R_2R_5 + R_1R_3R_5 + R_2R_3R_4 - R_1R_2R_3R_4 - R_1R_2R_3R_5 - R_1R_2R_4R_5 - R_1R_3R_4R_5 - R_2R_3R_4R_5 + 2R_1R_2R_3R_4R_5$ to obtain the following:

Component Level Aggregated to System DT:

(99.38%, 99.59%)

Component Level Aggregated to System OT:

(99.14%, 99.76%) .

The Bayesian Exponential Method.

Bayesian Exponential Prior.

For Component 1 data, from Table L1:

$$\widehat{E}(\lambda) = \overline{\lambda} = \mathbf{0.09507} \text{ and } \widehat{V}(\lambda) = s_{\lambda^2} = \mathbf{0.00008}.$$

These yielded the parameter estimates

$$\alpha = \left(\frac{0.09507^2}{0.00008} \right) = \mathbf{112.98} \text{ and } \beta = \left(\frac{0.09507}{0.00008} \right) = \mathbf{1188.38}.$$

For Component 2 data, from Table L3:

$$\widehat{E}(\lambda) = \overline{\lambda} = \mathbf{0.04956} \text{ and } \widehat{V}(\lambda) = s_{\lambda^2} = \mathbf{0.00007}.$$

These yielded the parameter estimates

$$\alpha = \left(\frac{0.04956^2}{0.00007} \right) = \mathbf{35.09} \text{ and } \beta = \left(\frac{0.04956}{0.00007} \right) = \mathbf{708}.$$

For Component 3 data, from Table L5:

$$\widehat{E}(\lambda) = \overline{\lambda} = \mathbf{0.04030} \text{ and } \widehat{V}(\lambda) = s_{\lambda^2} = \mathbf{0.00002}.$$

These yielded the parameter estimates

$$\alpha = \left(\frac{0.04030^2}{0.00002} \right) = \mathbf{81.21} \text{ and } \beta = \left(\frac{0.04030}{0.00002} \right) = \mathbf{2015}.$$

For Component 4 data, from Table L7:

$$\widehat{E}(\lambda) = \overline{\lambda} = \mathbf{0.02538} \text{ and } \widehat{V}(\lambda) = s_{\lambda^2} = \mathbf{0.00008}.$$

These yielded the parameter estimates

$$\alpha = \left(\frac{0.02538^2}{0.00008} \right) = \mathbf{8.05} \text{ and } \beta = \left(\frac{0.02538}{0.00008} \right) = \mathbf{317.25}.$$

For Component 5 data, from Table L9:

$$\widehat{E}(\lambda) = \overline{\lambda} = \mathbf{0.02215} \text{ and } \widehat{V}(\lambda) = s_{\lambda^2} = \mathbf{0.00003}.$$

These yielded the parameter estimates

$$\alpha = \left(\frac{0.02215^2}{0.00003} \right) = \mathbf{16.35} \text{ and } \beta = \left(\frac{0.02215}{0.00003} \right) = \mathbf{738.33}.$$

Bayesian Exponential Posterior Analysis.

$$\text{Component 1: } \hat{\lambda} = \left(\frac{23+112.98}{244.05+1188.38} \right) = \mathbf{0.09493}.$$

$$\text{Component 2: } \hat{\lambda} = \left(\frac{13+35.09}{244.05+708} \right) = \mathbf{0.05051}.$$

$$\text{Component 3: } \hat{\lambda} = \left(\frac{8+81.21}{244.05+2015} \right) = \mathbf{0.03949}.$$

$$\text{Component 4: } \hat{\lambda} = \left(\frac{5+8.05}{244.05+317.25} \right) = \mathbf{0.02325}.$$

$$\text{Component 5: } \hat{\lambda} = \left(\frac{2+16.35}{244.05+738.33} \right) = \mathbf{0.01868}.$$

The 80% two-sided probability intervals (TBPI) are

$$\text{Component 1: } \left(\frac{\chi_{0.2/2}^2(2 \times 23 + 2 \times 112.98)}{2(244.05 + 1188.38)}, \frac{\chi_{1-0.2/2}^2(2 \times 23 + 2 \times 112.98)}{2(244.05 + 1188.38)} \right)$$

$$= \left(\frac{241.63}{2864.86}, \frac{301.23}{2864.86} \right) = \mathbf{(0.08434, 0.10515)}.$$

$$\text{Component 2: } \left(\frac{\chi_{0.2/2}^2(2 \times 13 + 2 \times 35.09)}{2(244.05 + 708)}, \frac{\chi_{1-0.2/2}^2(2 \times 13 + 2 \times 35.09)}{2(244.05 + 708)} \right)$$

$$= \left(\frac{78.73}{1904.1}, \frac{114.13}{1904.1} \right) = \mathbf{(0.04135, 0.05994)}.$$

$$\text{Component 3: } \left(\frac{\chi_{0.2/2}^2(2 \times 8 + 2 \times 81.21)}{2(244.05 + 2015)}, \frac{\chi_{1-0.2/2}^2(2 \times 8 + 2 \times 81.21)}{2(244.05 + 2015)} \right)$$

$$= \left(\frac{154.29}{4518.1}, \frac{202.57}{4518.1} \right) = \mathbf{(0.03415, 0.04484)}.$$

$$\text{Component 4: } \left(\frac{\chi_{0.2/2}^2(2 \times 5 + 2 \times 8.05)}{2(244.05 + 317.25)}, \frac{\chi_{1-0.2/2}^2(2 \times 5 + 2 \times 8.05)}{2(244.05 + 317.25)} \right)$$

$$= \left(\frac{17.29}{1122.6}, \frac{35.56}{1122.6} \right) = \mathbf{(0.01540, 0.03168)}.$$

$$\text{Component 5: } \left(\frac{\chi_{0.2/2}^2(2 \times 2 + 2 \times 16.35)}{2(244.05 + 738.33)}, \frac{\chi_{1-0.2/2}^2(2 \times 2 + 2 \times 16.35)}{2(244.05 + 738.33)} \right)$$

$$= \left(\frac{25.64}{1964.76}, \frac{47.21}{1964.76} \right) = (0.01305, 0.02403).$$

The Bayesian estimators of $R(t)$ for $t = 1$ hour are

Component 1: $\hat{R}(t) = 90.95\%$

$$\hat{R}(t) = \left(\frac{\left(\frac{244.05}{1188.38} \right) + 1}{\left(\frac{244.05}{1188.38} \right) + \left(\frac{1}{1188.38} \right) + 1} \right)^{112.98+23}$$

Component 2: $\hat{R}(t) = 95.08\%$

$$\hat{R}(t) = \left(\frac{\left(\frac{244.05}{708} \right) + 1}{\left(\frac{244.05}{708} \right) + \left(\frac{1}{708} \right) + 1} \right)^{35.09+13}$$

Component 3: $\hat{R}(t) = 96.13\%$

$$\hat{R}(t) = \left(\frac{\left(\frac{244.05}{2015} \right) + 1}{\left(\frac{244.05}{2015} \right) + \left(\frac{1}{2015} \right) + 1} \right)^{81.21+8}$$

Component 4: $\hat{R}(t) = 97.70\%$

$$\hat{R}(t) = \left(\frac{\left(\frac{244.05}{317.25} \right) + 1}{\left(\frac{244.05}{317.25} \right) + \left(\frac{1}{317.25} \right) + 1} \right)^{8.05+5}$$

Component 5: $\hat{R}(t) = 98.15\%$

$$\hat{R}(t) = \left(\frac{\left(\frac{244.05}{738.33} \right) + 1}{\left(\frac{244.05}{738.33} \right) + \left(\frac{1}{738.33} \right) + 1} \right)^{16.35+2}$$

Substitute the appropriate values into $\hat{R}(t) = R_1R_4 + R_2R_5 + R_1R_3R_5 + R_2R_3R_4 - R_1R_2R_3R_4 - R_1R_2R_3R_5 - R_1R_2R_4R_5 - R_1R_3R_4R_5 - R_2R_3R_4R_5 + 2R_1R_2R_3R_4R_5$ to obtained the following:

Component Level Aggregated to System: $\hat{R}(t) = 99.50\%$.

The 80% two-sided probability intervals (TBPI) are

Component 1: $(90.02\% \leq \hat{R}(1) \leq 91.91\%)$

$\exp(-0.10515X1) \leq \hat{R}(1) \leq \exp(-0.08434X1)$.

Component 2: $(94.18\% \leq \hat{R}(1) \leq 95.95\%)$

$\exp(-0.05994X1) \leq \hat{R}(1) \leq \exp(-0.04135X1)$.

Component 3: $(95.62\% \leq \hat{R}(1) \leq 96.64\%)$

$\exp(-0.04484X1) \leq \hat{R}(1) \leq \exp(-0.03415X1)$.

Component 4: $(96.88\% \leq \hat{R}(1) \leq 98.47\%)$

$\exp(-0.03168X1) \leq \hat{R}(1) \leq \exp(-0.01540X1)$.

Component 5: $(97.63\% \leq \hat{R}(1) \leq 98.70\%)$

$\exp(-0.02403X1) \leq \hat{R}(1) \leq \exp(-0.01315X1)$.

Substitute the appropriate values into $\hat{R}(t) = R_1R_4 + R_2R_5$
+ $R_1R_3R_5 + R_2R_3R_4 - R_1R_2R_3R_4 - R_1R_2R_3R_5 - R_1R_2R_4R_5 - R_1R_3R_4R_5 -$
 $R_2R_3R_4R_5 + 2R_1R_2R_3R_4R_5$ to obtain the following:

Component Level Aggregated to System: $(99.33\%, 99.65\%)$.

Bibliography

1. Chay, S. C. "Use of Bayesian Method in Reliability Estimation," *1984 IEEE Proceedings Annual Reliability and Maintainability Symposium*, 16:216-221 (1984).
2. Chen, K. W. and Papadopoulos, A. S. "Bayesian System Reliability of the Generalized Exponential Model," *METRON*, 47(1-4):241-251 (1989).
3. Frickenstein, S. G. "Bayesian Reliability Assessment Applied to Operational Test and Evaluation: An Introduction," *RAC Quarterly*, Winter 1992:4-9 (1992).
4. Lemaster, R. M. *Application of Bayesian Reliability Concepts to Cruise Missile Electronic Components*. MS thesis, AFIT/GSM/LSG/89S-24. School of Systems and Logistics, Air Force Institute of Technology (AU), Wright-Patterson AFB OH, September 1989.
5. Martz, H. F., and R. A. Waller. "Bayesian Reliability Analysis of Complex Series/Parallel Systems of Binomial Subsystems and Components," *Technometrics*, 32(4):407-416 (1990).
6. Martz, H. F., and R. A. Waller. *Bayesian Reliability Analysis*. New York: John Wiley and Sons, 1982.
7. Martz, H. F., Waller, R. A., and Fickas, E. T. "Bayesian Reliability Analysis of Series Systems of

- Binomial Subsystems and Components," *Technometrics*, 30(2):143-154 (1988).
8. Press, S. J. *Bayesian Statistics: Principles, Models and Applications*. New York: John Wiley and Sons, 1989.
 9. Ross, S. M. *Probability Model*. San Diego: Academic Press, 1993.
 10. Sharma, K. K. and Bhutani, R. K. "Bayesian Reliability Analysis of a Series System," *Microelectronics and Reliability*, 34(4):761-763 (1994).
 11. Sharma, K. K. and Bhutani, R. K. "Bayesian Reliability Analysis of a Parallel System," *Reliability Engineering and System Safety*, 37:227-230 (1992).
 12. Villacourt, M. and Mahaney, M. "Designing a Reliability Demonstration Test on a Lithography Expose Tool Using Bayesian Techniques," *IEEE Transactions on Components, Packaging, and Manufacturing Technology*, 17(3):458-462 (1994).
 13. Weiler, H. "The Use of Incomplete Beta Functions for Prior Distributions in Binomial Sampling," *Technometrics*, 7:335-347 (1965).
 14. Willits, C. J. *Point and Interval Estimation of Series System Reliability Using Small Data Sets*. MS thesis, AFIT/GOR/ENS/ENC/94M-19. School of Engineering, Air

Force Institute of Technology (AU), Wright-Patterson AFB
OH, March 1994.

15. Willits, C. J., Dietz, D. C., and Moore, A.H.
"Series-System Reliability-Estimation Using Very Small
Binomial Samples," *IEEE Transactions on Reliability*,
46(2):296-302 (1997).

Vita

Captain Thuan H. Tran was born on [REDACTED] in [REDACTED]. He and his family arrived in America in June 1986. He graduated from high school (Dickinson High School) in Jersey City, New Jersey, in 1989 and attended the United States Air Force Academy Preparatory School in Colorado Springs, Colorado. With the assistance of an Air Force Reserve Officers Training Corps federal scholarship, he earned a Bachelor of Science degree in Mathematics from Stevens Institute of Technology in 1993.

Before arriving at AFIT in August 1996, Captain Tran was a Weapon System Analyst at the B-2 Combined Test Force, B-2 Operational Test Team, Edwards AFB, California.

As a follow-on to his work at AFIT, Captain Tran has been assigned to Headquarters, Air Force Material Command (AFMC), where he will be an analyst at the AFMC Study and Analysis Group in Wright-Patterson AFB, Ohio.

Captain Tran is an honor graduate of the United States Air Force Academy Preparatory School. He is also graduated with high honor from Stevens Institute of Technology. He is a member of the Omega Rho honor society. Captain Tran is single.

Permanent Address: [REDACTED]

[REDACTED] Electronic mail: [REDACTED]

REPORT DOCUMENTATION PAGE			Form Approved OMB No. 0704-0188	
Public reporting burden for this collection of information is estimated to average 1 hour per response, including the time for reviewing instructions, searching existing data sources, gathering and maintaining the data needed, and completing and reviewing the collection of information. Send comments regarding this burden estimate or any other aspect of this collection of information, including suggestions for reducing this burden, to Washington Headquarters Services, Directorate for Information Operations and Reports, 1215 Jefferson Davis Highway, Suite 1204, Arlington, VA 22202-4302, and to the Office of Management and Budget, Paperwork Reduction Project (0704-0188), Washington, DC 20503.				
1. AGENCY USE ONLY (Leave blank)	2. REPORT DATE March 1998	3. REPORT TYPE AND DATES COVERED Master's Thesis		
4. TITLE AND SUBTITLE USING BAYESIAN STATISTICS IN OPERATIONAL TESTING			5. FUNDING NUMBERS	
6. AUTHOR(S) Thuan Hoa Tran, Captain, USAF				
7. PERFORMING ORGANIZATION NAME(S) AND ADDRESS(ES) Air Force Institute of Technology Wright-Patterson AFB, OH 45433-6583			8. PERFORMING ORGANIZATION REPORT NUMBER AFIT/GOR/ENS/98M-25	
9. SPONSORING/MONITORING AGENCY NAME(S) AND ADDRESS(ES) Captain Robert Neher (DSN 246-8003) HQ AFOTEC/SAL 8500 Gibson Blvd SE Kirtland AFB, NM 97117			10. SPONSORING/MONITORING AGENCY REPORT NUMBER	
11. SUPPLEMENTARY NOTES Co-advisors: Maj Ed Pohl, 255-6565, epohl@afit.af.mil Maj William Murdock, 255-6565, wurdock@afit.af.mil				
12a. DISTRIBUTION AVAILABILITY STATEMENT Approved for public release; distribution unlimited			12b. DISTRIBUTION CODE	
13. ABSTRACT (Maximum 200 words) HQ Air Force Operational Test and Evaluation Center (AFOTEC) is responsible for the operational test and evaluation of major weapon systems during their acquisition phase. In operational testing at AFOTEC, it is often the case that not enough data or samples are available to make high confidence classical inferences on various statistics. The use of Bayesian statistical methods may be a solution in which higher confidence inferences can be made on statistics by using other sources of data. This research explored the applicability of Bayesian methods to the problem of determining the reliability of a series system, a parallel system, and a bridge system. The time to failure of each component in each system is assumed to be exponentially distributed. A basic binomial case is also evaluated. In general, using simulated data, the Bayesian methods produced confidence intervals that were much tighter than the classical inference methods, thus allowing a decision-maker to have higher confidence in making a decision. System level data and aggregated component level data produced a much tighter confidence interval than component level data aggregated to system.				
14. SUBJECT TERMS Bayesian Reliability Analysis			15. NUMBER OF PAGES 173	
			16. PRICE CODE	
17. SECURITY CLASSIFICATION OF REPORT Unclassified	18. SECURITY CLASSIFICATION OF THIS PAGE Unclassified	19. SECURITY CLASSIFICATION OF ABSTRACT Unclassified	20. LIMITATION OF ABSTRACT UL	