

Air Force Institute of Technology

AFIT Scholar

Theses and Dissertations

Student Graduate Works

12-1997

Using Cross-Eye Techniques to Counter Radio Frequency Agile Monopulse Processing

Gregory J. Meyer

Follow this and additional works at: <https://scholar.afit.edu/etd>



Part of the [Signal Processing Commons](#)

Recommended Citation

Meyer, Gregory J., "Using Cross-Eye Techniques to Counter Radio Frequency Agile Monopulse Processing" (1997). *Theses and Dissertations*. 5719.

<https://scholar.afit.edu/etd/5719>

This Thesis is brought to you for free and open access by the Student Graduate Works at AFIT Scholar. It has been accepted for inclusion in Theses and Dissertations by an authorized administrator of AFIT Scholar. For more information, please contact AFIT.ENWL.Repository@us.af.mil.



19980311 171

DISTRIBUTION STATEMENT A
Approved for public release;
Distribution Unlimited

DTIC QUALITY INSPECTED 4

DEPARTMENT OF THE AIR FORCE
AIR UNIVERSITY
AIR FORCE INSTITUTE OF TECHNOLOGY

Wright-Patterson Air Force Base, Ohio

AFIT/GE/ENG/97D-15

USING CROSS-EYE TECHNIQUES TO COUNTER RADIO
FREQUENCY AGILE MONOPULSE PROCESSING

THESIS

Gregory J. Meyer, First Lieutenant, USAF

AFIT/GE/ENG/97D-15

Approved for public release; distribution unlimited

The views expressed in this thesis are those of the author and do not reflect the official policy or position of the Department of Defense or the U.S. Government.

USING CROSS-EYE TECHNIQUES TO COUNTER RADIO
FREQUENCY AGILE MONOPULSE PROCESSING

THESIS

Gregory J. Meyer, B.S., M.B.A., M.S.

First Lieutenant, USAF

Presented to the Faculty of the Graduate School of Engineering
of the Air Force Institute of Technology
Air University in Partial Fulfillment of the
Requirements for the Degree of
Master of Science in Electrical Engineering



Dr. Vittal P. Pyati

Pyati



Dr. Byron M. Welsh

Welsh



Maj Michael A. Temple, PhD (chairman)

Temple

December 1997

Acknowledgements

I would like to thank all the engineering students of class GE97D at AFIT who have provided ideas and encouragement throughout my thesis work. I would also like to thank Tom Madden, my sponsor, who provided the problem and kept my thesis work practical.

Most importantly, I would like to thank my thesis committee chairman Major Michael Temple, Major Gerald Gerace and Doctor Vittal Pyati. Major Temple many times helped me organize my research and was constantly there to help flesh out new ideas and to help with editing chores. Major Gerace gave me and my entire class needed direction and mentoring in the early stages of this effort, and Dr. Pyati gave my advanced education in radar and electronic combat a solid mathematical foundation.

Gregory J. Meyer

Table of Contents

	Page
Approval Page	ii
Acknowledgements	iii
List of Figures	vi
Abstract	vii
I. Introduction	1
Background	1
Problem Statement	2
Definitions	2
Scope	3
II. Literature Review	4
Overview	4
Glint (Angle Noise)	4
“Simple” Cross-Eye Implementation	5
Retrodirective Cross-Eye Implementation	6
Phase Monopulse Systems	6
Monopulse Processing	9
ECCM Techniques	9
ECCM Considerations	10
III. Methodology	11
Techniques	11
Analysis Scope	11
Modeling and Simulation	12
Implementation	13
IV. Data and Analysis	14
Overview	14
Retrodirective Cross-Eye	14
Time Difference Of Arrival (TDOA)	16
Doppler Considerations	16
Synchronized Cross-Eye with a Low Radar Cross Section (RCS) Source	17
Time Difference Of Arrival (TDOA)	18
Doppler and Phase Considerations	19
Sensitivity of TDOA and Delta Doppler	21
Synchronized Cross-Eye Implementation	26

	Page
V. Results and Conclusions	29
Results	29
Doppler Error	31
Improvements	32
Conclusions	36
Recommendations	36

Figure	Page
2-1 "Simple" Cross-Eye Implementation	7
2-2 Retrodirective Cross-Eye	8
4-1 Intercept Geometry	15
4-2 Proof of Concept Model	23
4-3 Delta Doppler and TDOA as a Function of Aspect Angle	24
4-4 Pulse-to-Pulse Error Analysis	25
4-5 Synchronized Cross-Eye	27
5-1 Path Length Calculations	30
5-2 Synchronized vs Simple Cross-Eye Comparison	33
5-3 Polar Mapping of Interferometric Pattern to Target at 10km Distance	34
5-4 Polar Mapping of Interferometric Pattern to Target at 100km Distance	35

Abstract

Monopulse processing radars are a true threat to airborne platforms. Existing countermeasure techniques may not be able to deal with a monopulse processing radar with random, pulse-to-pulse Radio Frequency (RF) agility. This thesis examines the effects current cross-eye techniques have against RF agile threats and investigates an alternative form of cross-eye, synchronized cross-eye, to counter RF agile threats.

This thesis looks at hiding the entire skin return of the airborne platform by ensuring jamming waveforms from the two source cross-eye technique arrive at the appropriate time and Doppler frequency while distorting the phase information monopulse processing radars use to track an airborne target. Analysis shows that current cross-eye techniques can not meet the time requirement imposed by an RF agile threat, and any solution has geometrical constraints. This thesis recommends using synchronized cross-eye, a technique requiring a low Radar Cross Section (RCS) platform to be illuminated prior to the airborne platform to be protected as well as communication of timing and frequency information from the previous radar pulse between the two platforms.

Results of this thesis show that variations in time and frequency due to geometry are negligible, but Doppler frequency differences between the two platforms caused by a varying carrier frequency can not be anticipated. Furthermore, it is difficult to physically implement a system correcting for small Doppler frequency variations around a large carrier frequency. Fortunately, small Doppler variations at frequencies around 10GHz do not significantly alter jamming waveform effects at the threat radar location. As long as the threat does not separate targets at different relative velocities (Doppler frequencies) before the monopulse processor, any Doppler differences are insignificant.

USING CROSS-EYE TECHNIQUES TO COUNTER RADIO FREQUENCY AGILE MONOPULSE PROCESSING

I. Introduction

Background

Before Desert Storm it was felt that when flying over hostile air space, coalition aircraft would fly low to hide in the ground clutter. As it turned out, during Desert Storm coalition aircraft flew high to avoid the Anti-aircraft Artillery (AAA).

If our enemies anticipate US aircraft hiding in the ground clutter, coherent integration would be indicated with their ground radars allow the deterministic target to be more easily separated from random ground clutter. Now that more high-flying threats are indicated, smart adversaries of the United States may be driven to incorporating noncoherent integration in their radar processing.

A potentially powerful Electronic Counter Countermeasures (ECCM) technique that can theoretically be used to enhance noncoherent monopulse processing radar performance is Radio Frequency (RF) agility. Unlike frequency hopped communication systems, where both receiver and transmitter are physically separated, collocation of the monopulse radar receiver and transmitter make it theoretically possible to use a white noise generator to generate a random frequency within the RF bandwidth of interest. An RF agile threat radar is not limited to pseudonoise (PN) code with a "key" known to both receiver and transmitter that can be decoded

after a certain number of pulses. Theoretically, RF agile radars can be truly unpredictable (random) within an RF bandwidth.

A classic, brute force Electronic Countermeasures (ECM) technique available is to put a large coverpulse (transmitted energy) over the skin return (received energy) of the airborne platform to be protected. If no a priori knowledge of the frequency of the next pulse exists, it is next to impossible to implement this technique.

Problem Statement

The challenge is to protect airborne platforms from a threat radar that is completely unpredictable within a certain RF bandwidth by countering the threat radar. The threat will most likely employ a monopulse tracking radar. Although search and acquisition radars also pose potential problems, monopulse processing radars which provide direction finding (DF) capability are the focus of this thesis.

Definitions

Countering a threat can mean anything from evasion to destruction. For this thesis, countering simply means degrading the monopulse processing of the threat radar to ensure survival of an airborne platform. A threat is defined as any radar system employing monopulse processing techniques to estimate DF information of an airborne platform.

“Cross-eye or phase front distortion is a multiple source technique in which radar signals received at one point in an aircraft are amplified and retransmitted from a second point as far as possible from the first, while signals received at the second point are shifted in phase by 180 degrees and retransmitted from the first point.” [Boyd 1965] This form of cross-eye is referred

to as retrodirective cross-eye in this thesis to distinguish it from many other valid cross-eye techniques.

In a more general sense, monopulse processing radar systems compare phase information from an array of antennas to track the target. By transmitting from multiple sources at energy levels significantly higher than the skin return (received energy from the target), cross-eye techniques distort this phase information to induce tracking errors.

Scope

Multiple countermeasure solutions such as low observables (LO) technology, jamming, and the use of lethal Suppression of Enemy Air Defenses (SEAD) exist, but this thesis focuses on using cross-eye, a form of noncoherent jamming, to counter the monopulse processing radar threat.

II. Literature Review

Overview

Radar systems employing monopulse processing radar represent a true threat to airborne platforms and must be properly understood and respected for proper campaign planning. Theoretically, a monopulse radar can detect a target using a single radar pulse, determining a target's relative direction quickly and reliably. A radar that processes multiple sequential pulses to detect targets is subject to fluctuations in the radar cross section of the target due to rotation of the target and changes in the environment over time.

The scope of this literature review is to examine Electronic Countermeasures (ECM) techniques used to counter the monopulse radar, specifically cross-eye jamming techniques, and to examine the monopulse processing radar itself. The literature review extends from a general examination of scintillation to application examples of actual cross-eye jamming techniques (from simple to complex). Finally, the actual monopulse radar processing will be examined to show its susceptibility to the cross-eye jamming technique as well as Electronic Counter Countermeasures (ECCM) techniques the monopulse processing radar may employ to protect itself.

Glint (Angle Noise)

"Target glint is an error in target measurement due to interference of the reflections from different target elements. Glint can be falsely assumed to be variations in radar center of gravity between two target elements when in fact, glint error can bring the radar center of gravity outside the two target elements." [Barton 1988]

It is convenient to think of the two element problem as similar to two pebbles dropped next to each other in a pond. The expected concentric circle pattern emanating from each element (pebble) constructively and destructively interfere at various points. The radar cross section (height of wave) of the composite two element target will fluctuate much differently than the single element target. Nulls will be created in certain directions where energy is completely canceled by destructive interference (a cork at certain points in the pond will not bob at all).

“Simple” Cross-Eye Implementations

A simple example of a basic air-to-ground implementation of the cross-eye concept is most instructive (Figure 2-1).

Consider an aircraft approaching a ground tracking radar site head on with two transmit antennas on the wing tips and a receive only antenna in the nose. The transmit antennas retransmit the received pulse 180 degrees out of phase. A null will be produced at the center of the victim radar and at multiples of $r\lambda/d$, where r is the distance to the transmitting antennas and d is the antenna separation. Jamming effectiveness is actually inversely proportional to range as long as both transmitting antennas stay within the jammed antenna beamwidth.

Another way to consider the Cross-Eye jamming concept is as follows: A one-on-one tracking radar, whether it be monopulse or conical scan, seeks to align itself in the direction normal to the phase front of the electromagnetic waves reflected from the target. Since the Cross-Eye jamming concept uses two out of phase ECM sources, distortion of the phase front from the interference phenomena must lead to an increase in angular tracking errors. The value of the angular error depends on the distance between the two ECM sources, the phase shift of the signals emitted by the sources, and the amplitude ratio of the sources.

A principal drawback to this technique is the high sensitivity to the motion of the jamming aircraft. Yaw rates of tenths of degrees can create a dual source peak rather than a null at the center of the victim radar's antenna aperture. [Van Brundt, 1978]

“Retrodirective” Cross-Eye Implementations

A more sophisticated technique with less geometrical constraints is retrodirective cross-eye (Figure 2-2).

If we use two separate repeater paths from a transmit/receive pair, we can assure the two signals radiated by the jammer arrive 180 degrees out of phase independent of the angle-of-arrival of the victim radar. This value alone does not constitute good ECM operation for all values of θ because the effective distance, d , is reduced in accordance with the function $d \cos \theta$. However it should be noted that even at $\theta = 45$ degrees the reduction is only 29%.

Additional antenna requirements are needed for this implementation, though. First, the antenna-to-antenna spacing and directivity patterns requirement of the antenna pairs for each repeater must be precisely matched; and second, high isolation must be achieved between the transmit and receive antennas of each repeater and also between the transmit antenna of each repeater and the receive antenna of the opposite repeater.” [Van Brundt, 1978]

Phase Monopulse Systems

One of the first Russian phase monopulse radar system consists of four rigidly connected parabolic reflectors with feeds. One of the antennas is the transmitting antenna and the others are the receiving antennas; one of the receiving antennas is a reference for both azimuth and elevation channels. [Leonov and Fomachev, 1970]

Without loss of generality, consider a single channel of either the azimuth or elevation channel. The input from the two antennas is mixed (downconverted) and fed into a phase converter and an infrared frequency (IF) amplifier. Both outputs from the IF amplifiers are fed into a phase detector. The output of the phase detector feeds an error signal amplifier which feeds an antenna control system. [Leonov and Fomachev, 1970] This system is completely dependent on the received phase characteristics.

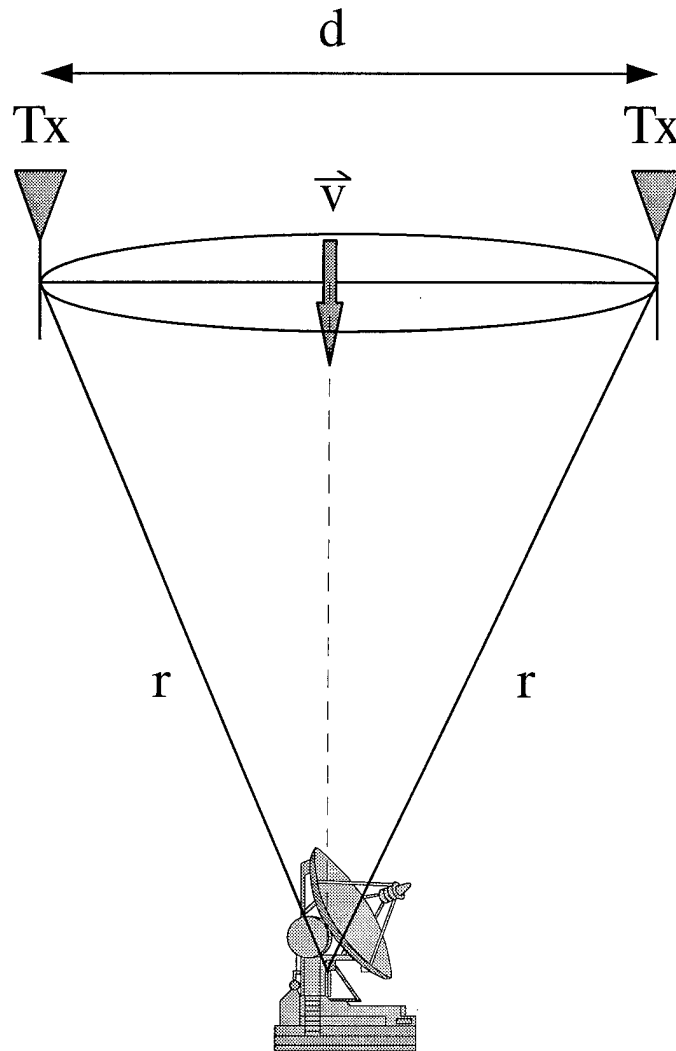
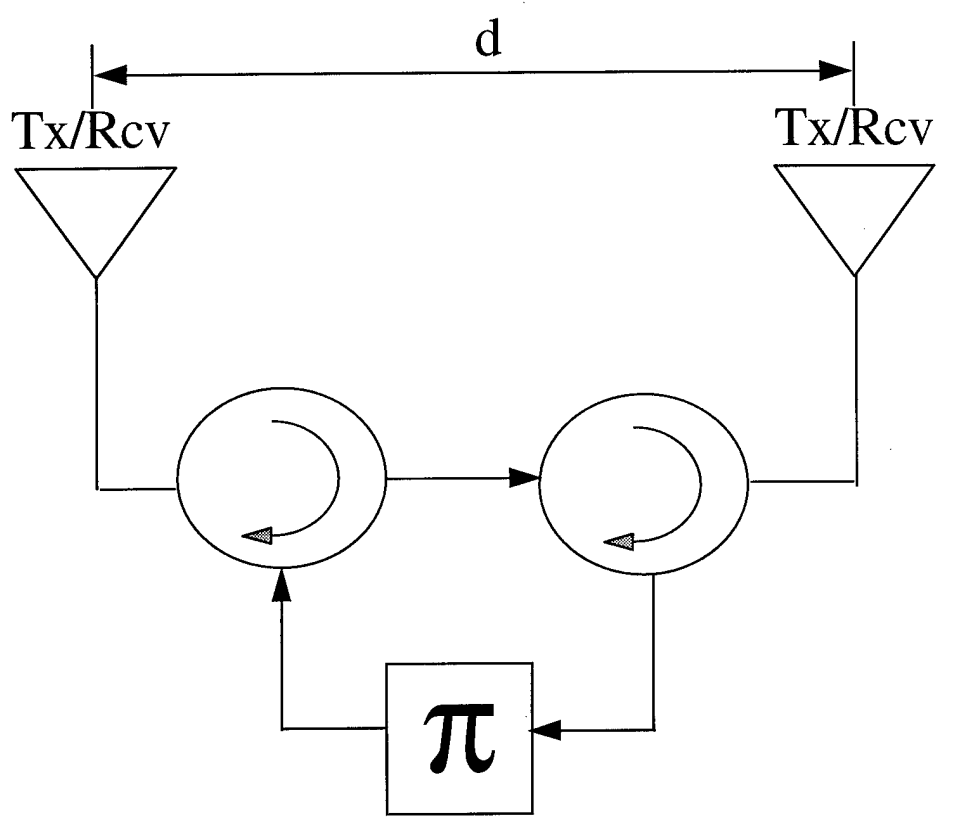

Figure 2-1 "Simple" Cross-Eye Implementation



 Denotes a lossless circulator
Input is redirected clockwise

Figure 2-2 Retrodirective Cross-Eye

The amplitude characteristics of the received pulse is minimum at the target, and maximum at the extremes. This result is valid only for a radar employing angle (phase) processing. When amplitude processing is employed, the radar will track the center of radiating “mass” of the two sources, and if they are of equal amplitude, the center. Phase deception techniques will not be effective. [Vakin and Shustov, 1969] Almost all monopulse systems employed today use phase processing, so this lack of effectiveness against amplitude processing is typically not a concern.

Monopulse Processing

The output of the exact monopulse processor is the real part of the difference pattern over the sum pattern of two antennas with slightly offset, identical gain patterns. [Sherman, 1984] The monopulse radar tracks where this output is equal to zero. A plot of the exact monopulse processor output as a function of azimuth angle typically produces what are called “S” curves. Using the monopulse processor output as the input to an antenna control system, it is theoretically possible to track the target. In the simple cross-eye case, when the radar is pointed directly at the approaching aircraft, the sum pattern is identically zero driving the exact monopulse processor output toward infinity; thus, the monopulse processing radar is strongly driven away from tracking the target.

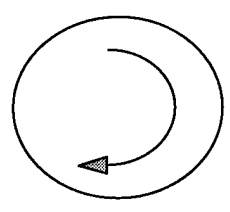
ECCM Techniques

Monopulse radar systems typically employ ECCM techniques to preserve angle accuracy (phase information) in the presence of ECM. Three such ECM techniques include short pulse phase processing, bistatic radar, and Radio Frequency (RF) agility.

Short pulse processing is an ECCM technique whereby “phase information can be processed on a short amount of the received pulse. If just the first 100 nanoseconds of the received pulse are used to determine the target position, a smart cross-eye jammer may not be able to respond in time due to path loss between the two antennas across the repeater path.”

[Golden, 1987]

Frequency agility may consist simply of the capability of fast mechanical tuning or, in the ultimate form, a capability of changing frequency on a pulse-to-pulse basis. A related technique, called frequency diversity, consists of choosing the frequencies of the individual radars in a radar network so that they are distributed through the entire spectrum of frequencies that are suitable for search radars. The combination of frequency diversity with frequency agility causes maximum spreading of the available jamming energy necessitating the dilution of a jamming effort in order to cover the search frequency band. [Boyd, 1965]

Bistatic radar (any radar where the receive antenna and transmit antenna are physically separated) presents an extremely difficult problem. Given that the cross-eye technique places a null in the direction of the transmitting antenna, the receiving antenna is not effectively jammed. Semiactive homing missiles are a form of bistatic radar--the missile houses the receive antenna, and the system that launched the missile usually provides the transmitted energy, so cross-eye is not effective against semiactive homing missiles.

ECCM Considerations

Any analysis of cross-eye jamming to counter phase comparison monopulse radar must consider the possibility of encountering the ECCM techniques discussed previously. Given a future threat, unpredictable within a sizable RF bandwidth, classic, brute force techniques are no longer possible. Path loss and processing time become limiting factors and determine if current cross-eye techniques, specifically retrodirective cross-eye, can respond in time to counter short pulse processing and RF agility ECCM techniques.

III. Methodology

Techniques

Existing theories on cross-eye jamming have not adequately addressed a Radio Frequency (RF) agile threat. This thesis begins with an examination of current retrodirective cross-eye techniques against the threat and proposes an alternate cross-eye implementation, synchronized cross-eye, to deal with the agile RF threat. Although retrodirective cross-eye has already been examined, the synchronized cross-eye implementation needs further development and illustration.

Analysis Scope

Current and proposed cross-eye techniques are analyzed from both a frequency domain and time domain perspective to ensure jamming waveforms arrive at the threat radar location and effectively cover the skin return over the entire pulse duration at the correct frequency. This leads to a separate Time Difference Of Arrival (TDOA) analysis to examine time domain and a Doppler analysis to examine frequency domain effects for both techniques.

Complex exponentials of typical threat radar waveforms are tracked from transmission at the threat, to arrival at each antenna, to retransmission from each antenna, to the final waveforms that arrive at the threat radar location. These complex exponents are of the form $j(\omega t + \phi)$ where ω is the frequency in radians per second and ϕ is the phase in radians. Theoretically, cross-eye techniques produce two waveforms that arrive at the same frequency and 180° out of phase.

Modeling and Simulation

A crucial assumption of synchronized cross-eye is that TDOAs and frequency differences between antennas on a pulse-to-pulse basis are relatively constant. This is verified using a simple flight profile and typical radar parameters. Aspect angle from the platform to be protected to the threat radar is a natural reference and all geometries are tied to this one parameter to produce final results.

Another simulation uses the proposed synchronized cross-eye technique to verify the technique produces results similar to simple cross-eye at typical aspect angles within preset geometrical constraints. This simulation is the final proof of concept model to validate the technique. The object of this simulation is to duplicate Van Brundt's interferometric pattern (the phase interaction between the two sources) across the victim radar, and success is determined accordingly.

The interferometric pattern is a comparison of path length differences for two sources 180° out of phase in terms of wavelengths. Given the processing characteristics of the monopulse radar, the interferometric pattern characteristics determine stable and unstable tracking points for the victim radar. When the path lengths differ by any integer multiple of a wavelength, the sources destructively interfere and create a null (an unstable tracking point). When the path lengths differ by any integer multiple of a wavelength plus a half wavelength, the sources constructively add and create a peak (a stable tracking point). This interferometric pattern is much easier to produce and understand than the actual output of the monopulse processor and is the final characterization of cross-eye performance at any geometry for this thesis.

The interferometric pattern may be used to create a polar plot showing how nulls and peaks at the threat radar correspond to azimuth angles to the airborne platforms in the model. Using the vector from the threat radar to the center of the two sources as a reference vector, moving a distance d normal to the reference vector from the threat radar corresponds to moving the threat radar in azimuth an angle of $\arctan(d/R)$ from the center of the two sources where R is the distance to the center of the two sources. Figures 5-3 and 5-4 provide clarification of this complicated coordinate transformation.

Implementation

A block diagram system implementation of synchronized cross-eye is proposed. The realizability of each part of the design is examined to identify potential implementation problems.

IV. Data and Analysis

Overview

A primary concern of campaign planners is the protection of airborne platforms from a monopulse tracking radar. This thesis takes this one step further and postulates a future threat with pulse-to-pulse RF agility. Using the cross-eye techniques outlined previously, how can we counter the truly RF agile threat with cross-eye?

Results of this thesis are anticipated to provide an estimate of the value of developing this next generation threat. If current countermeasure techniques and tactics can be easily modified to deal with pulse-to-pulse RF agility, the development of an RF agile threat would be wasteful; however, if pulse-to-pulse RF agility proves uncounterable, the expense and complexity associated with developing an RF agile threat is justifiable.

Retrodirective Cross-Eye

The retrodirective cross-eye implementation where both antennas are located on the extremes of an airborne platform can not effectively jam the agile RF threat. The Time Difference Of Arrival (TDOA) from one antenna does not allow ECM arriving from both sources to completely cover the skin return (reflected energy) of both sources. Retrodirective cross-eye, though, does transmit ECM from two different sources that do arrive at the threat at exactly the same frequency as measured at the threat radar (no Doppler difference) and travel the same path lengths.

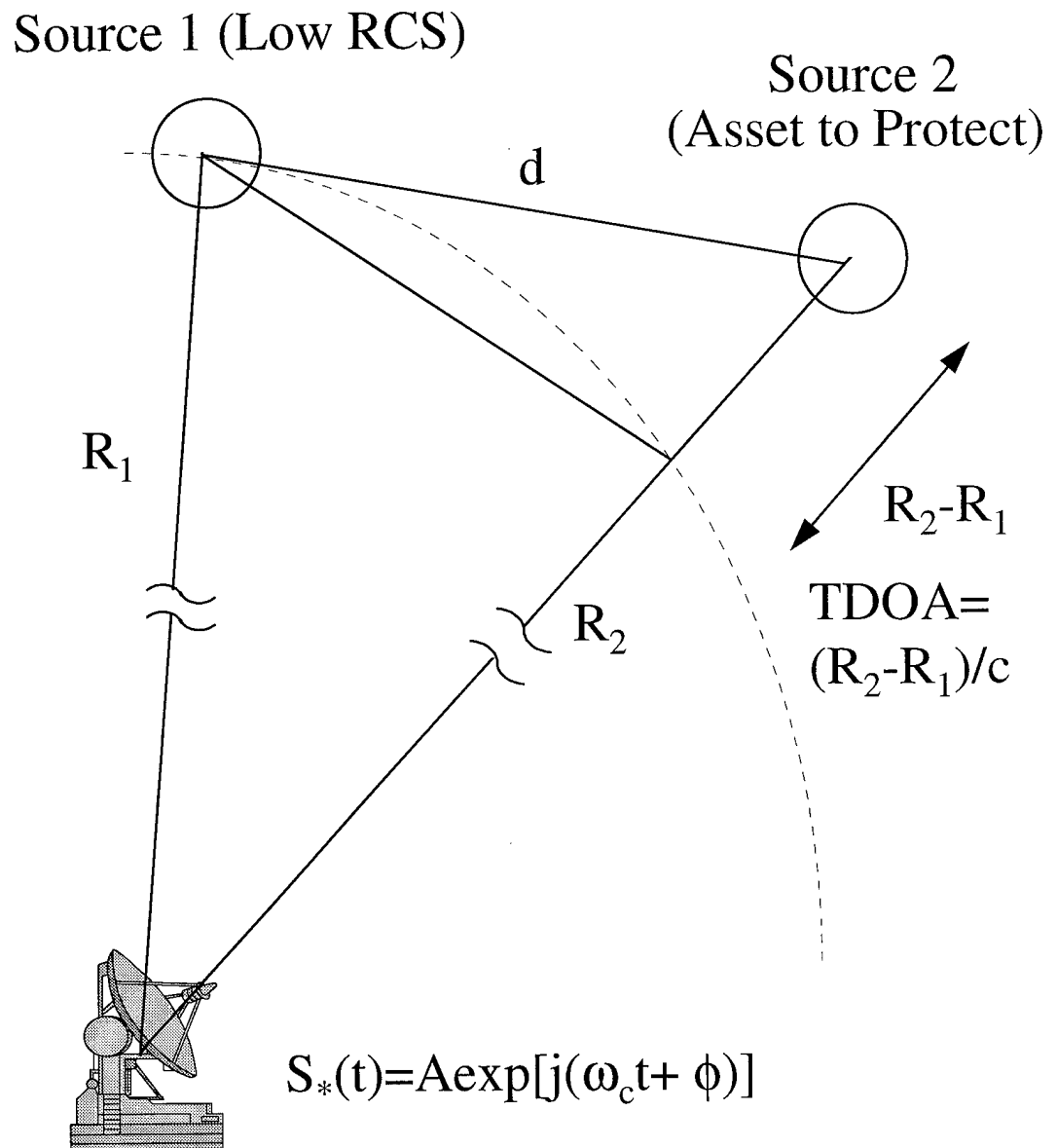

Figure 4-1 Intercept Geometry

Time Difference Of Arrival (TDOA).

Considering the truly agile RF threat, the antennas in the retrodirective cross-eye implementation are illuminated at two separate times in all instances except for a head on or tail on engagement. With a 45° angle of approach, 40m wingtip separation, and two antennas connected fiber optically (a propagation constant of .8 times the speed of light, $.8c$), the delay of any ECM transmitted from the antenna illuminated first due to propagation delay alone is approximately 260 ns. This is not fast enough to counter a short pulse radar or one employing ECCM techniques to derive angle information on the leading edge of the pulse.

Doppler Considerations.

With retrodirective cross-eye, the retrodirective nature of the implementation ensures the jamming signals arrive at the threat with equal frequency. Energy received by antenna one is reradiated from antenna two with the addition of 180° of phase; energy received by antenna two is directly reradiated from antenna one without any additional phase shift. The path lengths are regulated to keep them equal in length. The following equations represent the complex waveform generated at the threat (4.1), received at the platform (4.1a and 4.1b), transmitted at the platform (4.2a and 4.2b), and received back at the threat (4.3a and 4.3b). In these equations, A is the amplitude of the wave, ω_c is the carrier frequency, and ϕ is the arbitrary starting phase as transmitted from the threat radar (Equation 4.1). Phase delay, ϕ_p is due to propagation along source one to source two, R_1 is the distance to antenna one, R_2 is the distance to antenna two, k is the propagation constant ($2\pi/\lambda$), ω_{d1} is the Doppler shift due to the relative radial velocity of source one, and ω_{d2} is the Doppler shift due to the relative radial velocity of source two.

$$(4.1) \quad S_*(t) = Ae^{j(\omega_c t + \phi)}$$

$$(4.2a) \quad S_{R1}(t) = \frac{S_*(t)e^{j\omega_{d1}t}e^{-jkR_1}}{4\pi R_1}$$

$$(4.2b) \quad S_{R2}(t) = \frac{S_*(t)e^{j\omega_{d2}t}e^{-jkR_2}}{4\pi R_2}$$

$$(4.3a) \quad S_{T1}(t) = S_{R2}(t)e^{-j\phi_D}$$

$$(4.3b) \quad S_{T2}(t) = S_{R1}(t)e^{-j\pi}e^{-j\phi_D}$$

$$(4.4a) \quad S_{J1}(t) = \frac{S_{T1}e^{j\omega_{d1}t}e^{-jkR_1}}{4\pi R_1}$$

$$(4.4b) \quad S_{J2}(t) = \frac{S_{T2}e^{j\omega_{d2}t}e^{-jkR_2}}{4\pi R_2}$$

Synchronized Cross-Eye with a Low Radar Cross Section (RCS) Source

If the implementation can be altered to add a low RCS platform deployed remotely from the airborne platform, favorable geometries exist against the pulse-to-pulse agile RF threat. The low RCS platform must be illuminated first so that both antennas can transmit simultaneously and compete with the aircraft skin return. Platforms must “communicate” with each other (fiber optically or by laser communication) and may only “communicate” information about previous

pulses. In this context, “communicate” means to share frequency and time information received at the platform locations.

How to ensure a favorable geometry can be introduced is still a major problem. The low RCS platform may have to be strategically positioned to produce a favorable geometry or multiple low RCS platforms may be required. Using a delay based on the Time Difference Of Arrival (TDOA) of the received waveforms at the two platforms synchronizes the jamming waveforms in time and covers the skin return of the asset to be protected. Frequency and phase synchronization of the jamming waveforms is still necessary to duplicate the simple cross-eye interferometric pattern. This proposed solution, synchronizing the jamming waveforms as much as possible in time, frequency, and phase, is aptly named synchronized cross-eye in this thesis.

The nonretrodirective implementation causes a Doppler difference between the two transmitted waveforms as measured at the threat. If this Doppler difference is not accounted for, the jamming from the two sources can be perceived as two separate targets at higher energy levels than normal skin returns, but only if the threat does Doppler processing before monopulse processing. Assuming Doppler processing is done after the sum and difference patterns are formed, small frequency differences are not a problem as long as the phase information is truly synchronized.

Time Difference Of Arrival (TDOA).

Assuming RCS platform is illuminated first, the airborne platform to be protected needs to insure its transmitted ECM waveform arrives at the threat location at exactly the same time as the ECM radiated from the low RCS platform and last for the same amount of time. To accomplish this, received energy at the antenna on the airborne platform is repeated at the received frequency. At the low RCS platform, the received signal is repeated 180° out of phase and has an additional time delay equal to the Time Difference Of Arrival (TDOA) of the current

pulse from the wave transmitted from the antenna on the airborne platform. Because geometrical changes from one pulse to the next are relatively insignificant, TDOA from the previous pulse, or the result of a predictive model utilizing previous pulses, is almost exactly equivalent to the TDOA from the current pulse. The low RCS platform imposes a 180° phase shift on the received waveform and a delay of twice the TDOA of the previous pulse to accomplish the required phase and time synchronization. Note that it is impossible to use the time ECM is transmitted from the aircraft antenna as a reference since communication between sources is not possible until at least one pulse has been processed.

Doppler and Phase Considerations.

Given the low RCS platform is illuminated before the airborne platform, do the two transmitted jamming waveforms arrive at the ground receiver with the same frequency if both platforms are traveling at different radial velocities relative to the ground receiver? It is a great mistake to use the far field approximation to neglect Doppler frequency differences between both moving platforms. A difference that is one part per 100 million is equal to 100 Hz with a carrier frequency of 10 GHz, a considerable frequency difference considering actual Doppler frequencies range from 0 to 100 Hz.

With the low RCS platform moving at V_{REL1} , the aircraft moving at V_{REL2} , and a ground radar transmitting at a carrier frequency f_c , an antenna on the low RCS platform receives a signal at a frequency of $f_c + f_{D1}$ and an antenna on the aircraft receives a signal at a frequency of $f_c + f_{D2}$, where f_{D1} and f_{D2} are the Doppler frequency shifts due to velocities V_{REL1} and V_{REL2} , respectively. If both platforms transmit ECM at their received frequencies, the ground radar will receive two signals, one at $f_c + 2f_{D1}$, and one at $f_c + 2f_{D2}$. Equations 4.5a to 4.7b follow to illustrate the frequency problems any nonretrodirective implementation will have due to relative Doppler differences.

Equations 4.5a to 4.7b illustrate how a phase error is introduced by having the jamming waveforms travel different path lengths to the threat radar. To account for the phase difference, it is necessary to introduce a time delay at the low RCS platform equal to twice the TDOA (TDOA = $[R_2 - R_1] / c$) to correct for the phase error from Equations 4.5a and 4.5b to Equations 4.7a and 4.7b.

$$(4.5a) \quad S_{R1}(t) = \frac{S_*(t)e^{j\omega_{d1}t}e^{-jkR_1}}{4\pi R_1}$$

$$(4.5b) \quad S_{R2}(t) = \frac{S_*(t)e^{j\omega_{d2}t}e^{-jkR_2}}{4\pi R_2}$$

$$(4.6a) \quad S_{T1}(t) = S_{R1}(t)e^{-j\pi}$$

$$(4.6b) \quad S_{T2}(t) = S_{R2}(t)$$

$$(4.7a) \quad S_{R1}(t) = \frac{S_{T1}(t)e^{j\omega_{d1}t}e^{-jkR_1}}{4\pi R_1}$$

$$(4.7b) \quad S_{R2}(t) = \frac{S_{T2}(t)e^{j\omega_{d2}t}e^{-jkR_2}}{4\pi R_2}$$

To account for the perceived frequency difference at the threat, the synchronized cross-eye implementation introduces a frequency change of twice the frequency difference between both sources in addition to the phase and time delay. Again, communication is not possible

before the next pulse, but the geometry does not significantly change on a pulse-to-pulse basis. Modulating by twice the frequency difference calculated from the previous pulse after the 180° phase shift causes both ECM waves to arrive at the threat at the same frequency.

Doppler frequency variations do not depend on geometry alone--the jamming waveforms only arrive at the exact frequency if the carrier frequency does not vary from pulse-to-pulse. Given $f_{\text{Doppler}} = 2v_r f_c / c$, where v_r is the radial velocity of the target, f_c is the carrier frequency, and c is the speed of light, Doppler frequency is seen to vary with carrier frequency as well as geometry (through v_r). As long as the carrier frequency of the next pulse does not significantly vary, this error should be small. With a threat that operates from 10 GHz to 11 GHz, the relative Doppler difference between sources (designated $\Delta\text{Doppler}$ throughout this thesis) can be off by as much as 10 %. But with a threat that operates from 5 GHz to 10 GHz $\Delta\text{Doppler}$ can be off by as much as 100 %.

Sensitivity of TDOA and $\Delta\text{Doppler}$

To verify that TDOA and $\Delta\text{Doppler}$ do not significantly vary on a pulse-to-pulse basis, a simple profile of the two platform configuration moving relative to a stationary ground radar is reconstructed using modeling and simulation. Using a spread sheet to recreate the geometries of the two antennas vis a vis the threat, the variations in parameters from pulse-to-pulse are easily calculated.

The threat radar is characterized as having a carrier frequency of 10 GHz with a Pulse Repetition Interval (PRI) of 10 μs . The platforms are separated by 40 meters and moving at 100 m/s straight and level approaching the ground radar at 10 km at the closest point; one platform is following directly behind the other. The parameters of interest, TDOA and $\Delta\text{Doppler}$, are

compared to the aspect angle of the two platforms--an angle measured from the threat radar to a point in the center of the two platforms. Because of the symmetric nature of the problem, this aspect angle uses the point at which both platforms are equidistant from the threat radar as a 0° reference (see Figure 4-2). Both parameters change signs when the aspect angle changes sign, so negative aspect angles are not plotted. The results of this model follow as Figure 4-3 and Figure 4-4.

The crucial issue is how much does each parameter change on a pulse-to-pulse basis? Of the two parameters, the largest variance is changes in TDOA at aspect angles close to 0° , and this reaches at most a fifty parts per billion (PPB) change at a 0° angle of approach (Figure 4-4). Note that Δ Doppler is on the order of 10 Hz. If Doppler differences can be perceived by the threat, they need to be corrected for. If the threat employs Doppler processing, both platforms must appear to move at the same relative radial velocity.

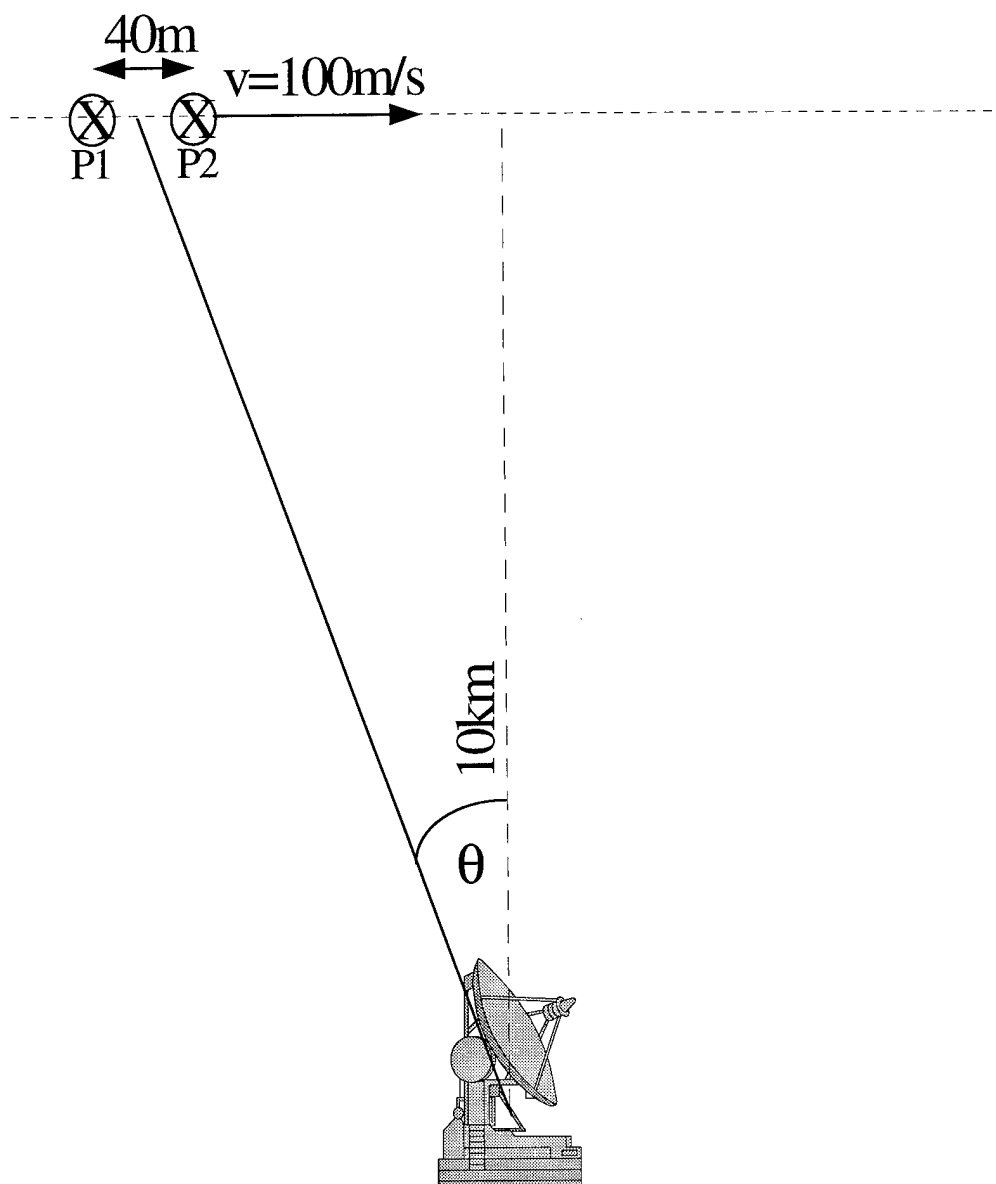

Figure 4-2 Proof of Concept Model

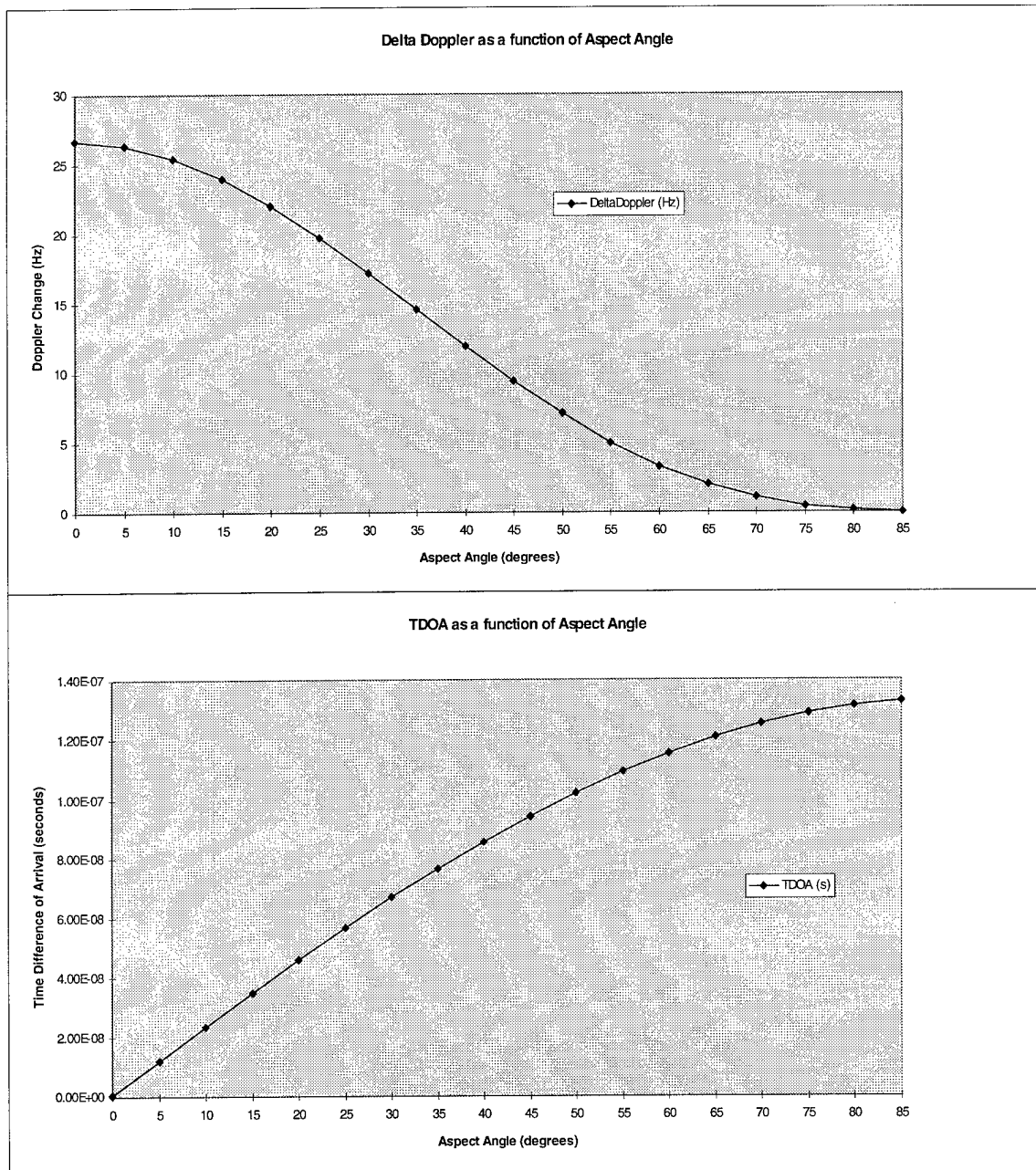

Figure 4-3 Δ Doppler and TDOA as a Function of Aspect Angle

FLIGHT ERROR ANALYSIS

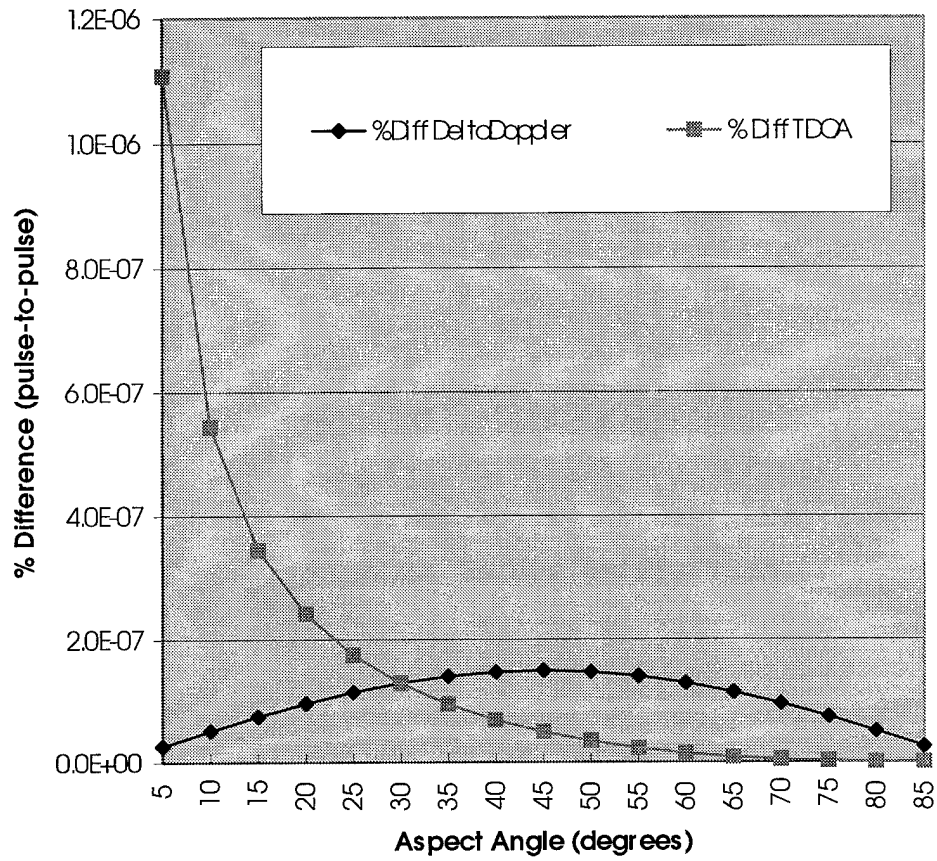

Figure 4-4 Pulse-to-Pulse Error Analysis

Synchronized Cross-Eye Implementation

To achieve effective jamming at the threat location, the dual source jamming waveforms must arrive at the same time and frequency. The waveform received the low RCS source (antenna two) is shifted in phase by 180° , modulated by two times $\Delta\text{Doppler}$, and then delayed by two times TDOA (Figure 4-5).

Unlike the retrodirective cross-eye implementation, isolation between the two signal propagation paths is not a problem. The timing constraints of the problem prevent transmitting received signals at the opposite antenna. On the other hand, preserving the phase cancellation effect at the threat now requires precise control of the phase and frequency of both transmitted waveforms without using identical propagation path lengths.

Is this block diagram implementation practical? The 180° phase shifter and the variable delay line are not difficult to implement with present technology. The variable modulator is perhaps the greatest technological problem. Although adding two times $\Delta\text{Doppler}$ in frequency to the carrier frequency is the goal, modulating and removing the unwanted sideband is the only feasible implementation. For the synchronized cross-eye implementation, the variable modulator must modulate a signal around 10 GHz by -100 Hz to 100 Hz using a band pass filter or a notch filter to remove the unwanted sideband. For example, a -10 Hz change in frequency requires modulating by 10 Hz and filtering out the sideband centered at 10,000,000,010 Hz and preserving the lower sideband centered at 9,999,999,990 Hz, a difficult requirement requiring a robust filter design. Because this filter is implemented prior to amplification, the power requirements are quite small, but the closeness of the sidebands still poses problems.

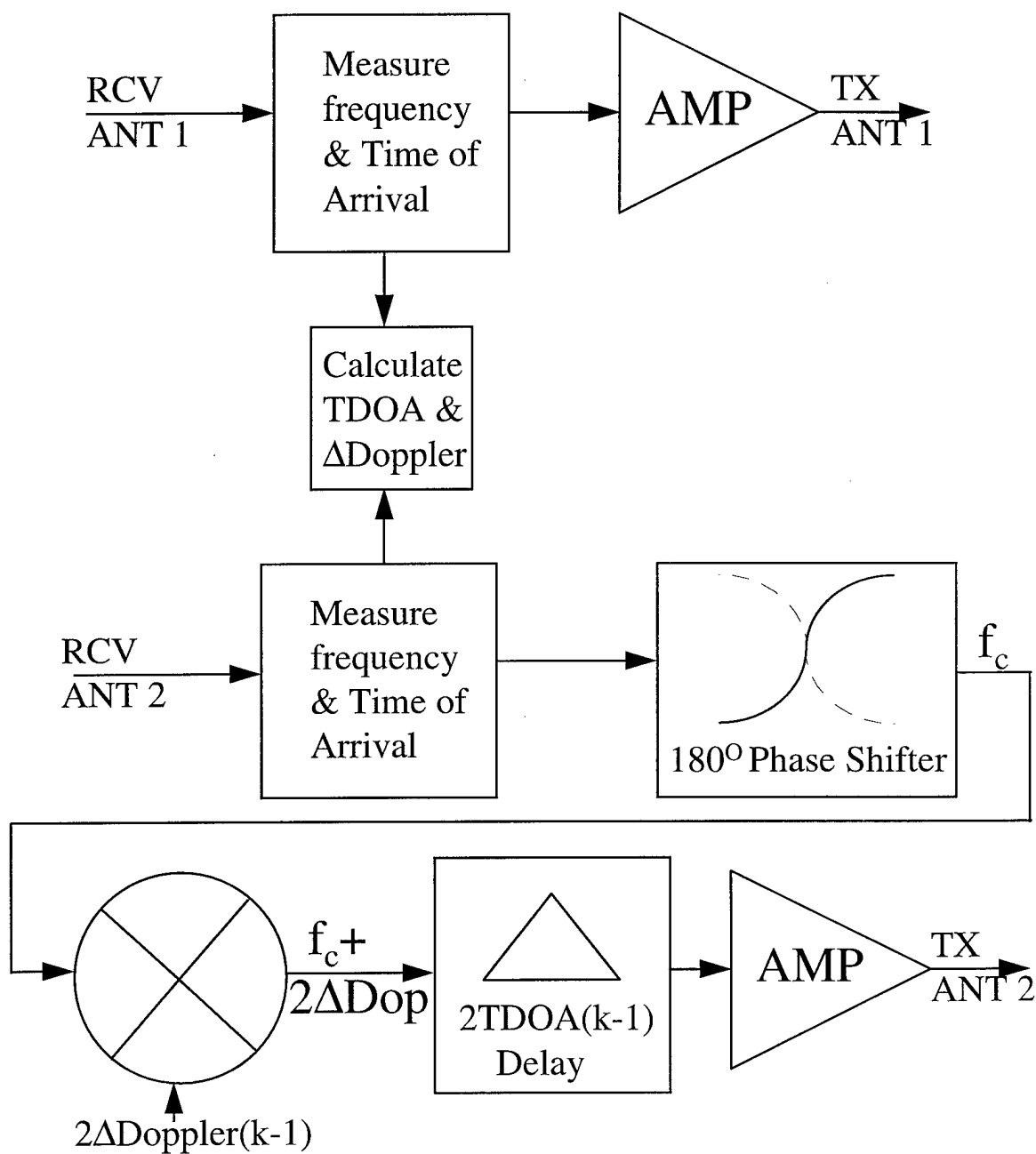

Figure 4-5 Synchronized Cross-Eye

This implementation neglects errors in Doppler frequency differences due to variations in the carrier frequency from pulse-to-pulse. As shown earlier, the maximum possible frequency difference between the ECM waveform generated at the low RCS source and the asset to be protected is a function of the bandwidth of the threat and the lower frequency limit of the threat. In fact, the maximum error due to frequency changes is the bandwidth divided by the lower frequency limit.

V. Results and Conclusion

Results

In a proof of concept model, synchronized cross-eye is compared to the simple cross-eye technique described by Van Brundt. The parameters of the model used to justify the relative constancy of Δ Doppler and Time Difference Of Arrival (TDOA) on a pulse-to-pulse basis are maintained. The carrier frequency is 10 GHz, the separation between sources is 40 meters, and the distance to the closest source is 10 km.

The two sources are positioned relative to the threat so that the baseline distance between the source illuminated first and a point exactly 10 km to the second source is exactly 30m. This allows a complete analogy to be constructed between synchronized cross-eye with the proposed constraints and Van Brundt's simple cross-eye example with 30m wingtip separation (Figure 5-1). Van Brundt predicts a 10m separation between nulls in the interferometric pattern ($10m = r\lambda/d = 10,000 * .03/30m$) where r is the distance to the center of the two sources, λ is the wavelength and d is the separation of the sources. [Van Brundt, 1978] Nulls will occur when the path length between 0° and 180° phase points differ by any integer multiple of a wavelength.

Synchronized cross-eye is an adaptive technique which attempts to artificially introduce a simple cross-eye waveform at the threat radar for more than one geometry; simple cross-eye only works for a head on or tail on engagement. In the synchronized cross-eye case one of the sources is actually located further away than in the simple cross-eye case. Control over the interference pattern between the two sources is identical at the center point of the victim radar ($d=0$ in Figure 5-1), but will slightly differ at all other points along the radar aperture. To verify

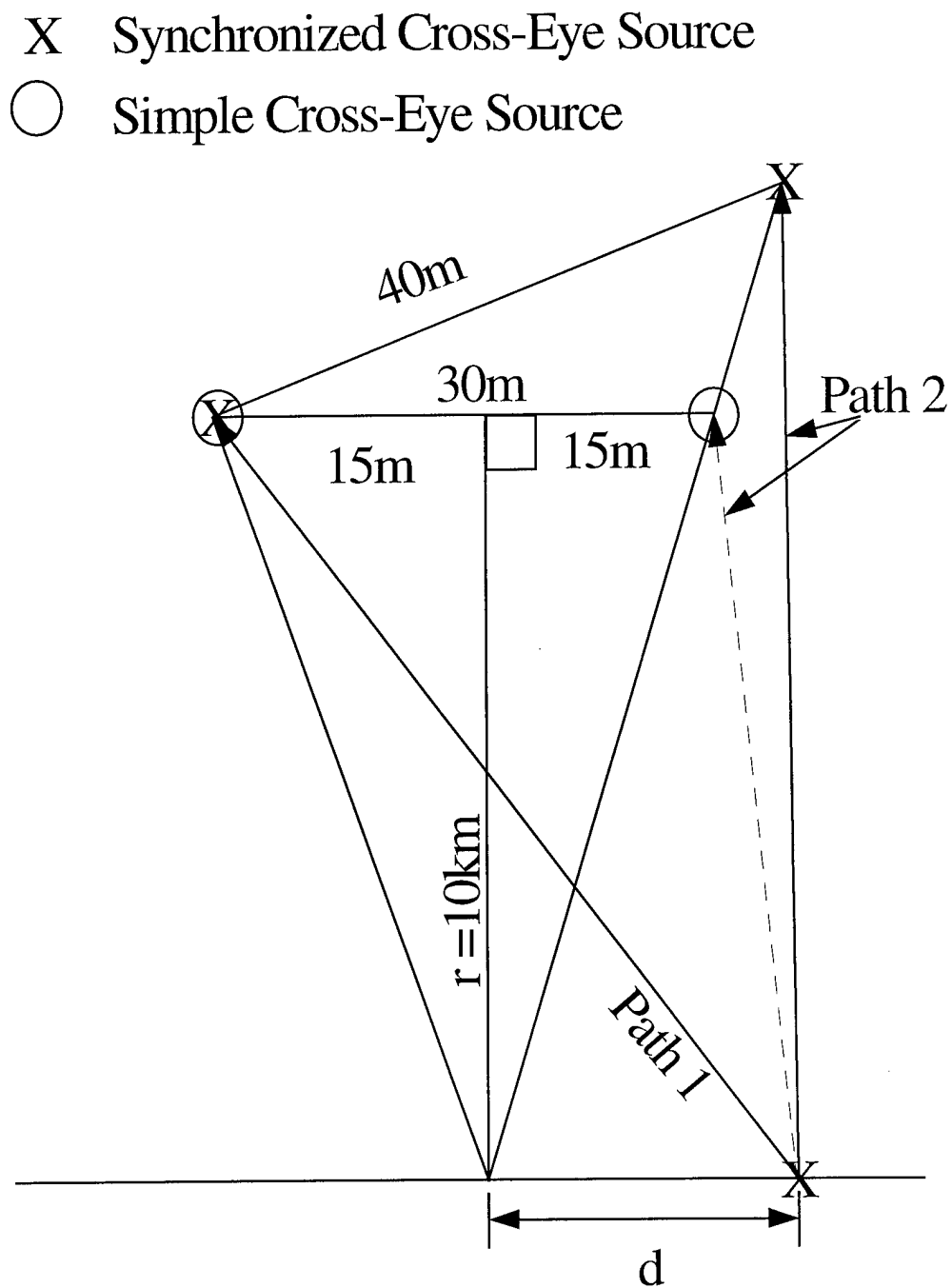

Figure 5-1 Path Length Calculations

that synchronize cross-eye jamming is effective, it is necessary to closely approximate Van Brundt's interference pattern across the victim radar aperture.

Rather than reproduce the output of the monopulse processor, the model will compare path differences between a 0° phase point (the actual source first illuminated in Figure 5-1) and a 180° phase point (the actual source two in the simple cross-eye case, but an artificial point located the exact distance to simple cross-eye source two but along a path to synchronized cross-eye source two). This is equivalent to generating synchronized cross-eye at the two sources, but provides a complete analogy to the simple cross-eye case. The path difference in wavelengths uniquely determines the interferometric pattern generated at the threat location.

As Figure 5-2 shows, the difference between synchronized cross-eye and simple cross-eye is imperceptible. Movement in any direction from the center of the threat radar aperture causes the synchronized cross-eye nulls (integer multiples of a wavelength) to shift slightly to the left of the simple cross-eye nulls. The distance between synchronized cross-eye nulls and simple cross-eye nulls widens as the distance increases.

Doppler Error.

It is important to understand how small differences in frequencies at both jamming sources affect the interferometric pattern at the victim radar. As it is impossible to know the frequency of the next pulse, it is also impossible to completely synchronize both jamming sources in frequency. Moreover, frequency synchronization presents many more implementation problems than time and phase synchronization which only involve only calculating the correct amount of time delay to impose on one of the sources.

Frequency differences between sources may be as high as 27 Hz (Figure 4-2) in a typical scenario. The previous simulation with one source having a 100 Hz Doppler shift shows a negligible change in the interferometric pattern. At 10 GHz the 10 km path length is

approximately 33,000 wavelengths; a 100 Hz difference (10^8 change) in frequency is about a .00033 wavelength difference in phase, not enough to significantly alter the interferometric pattern.

Improvements.

Most Electronic Countermeasures (ECM) are less effective as range to the victim radar decreases. Cross-eye jamming performance improves as range is reduced in at least one way. The number of stable and unstable tracking points within the two source baseline increases as range decreases (Figures 5-3 and 5-4). The number of stable tracking points also increases with increasing baseline distance (null separation is $r\lambda/d$). Maximizing the physical source separation, as well as seeking geometries that maximize the radial separation relative to the threat, should improve jamming performance.

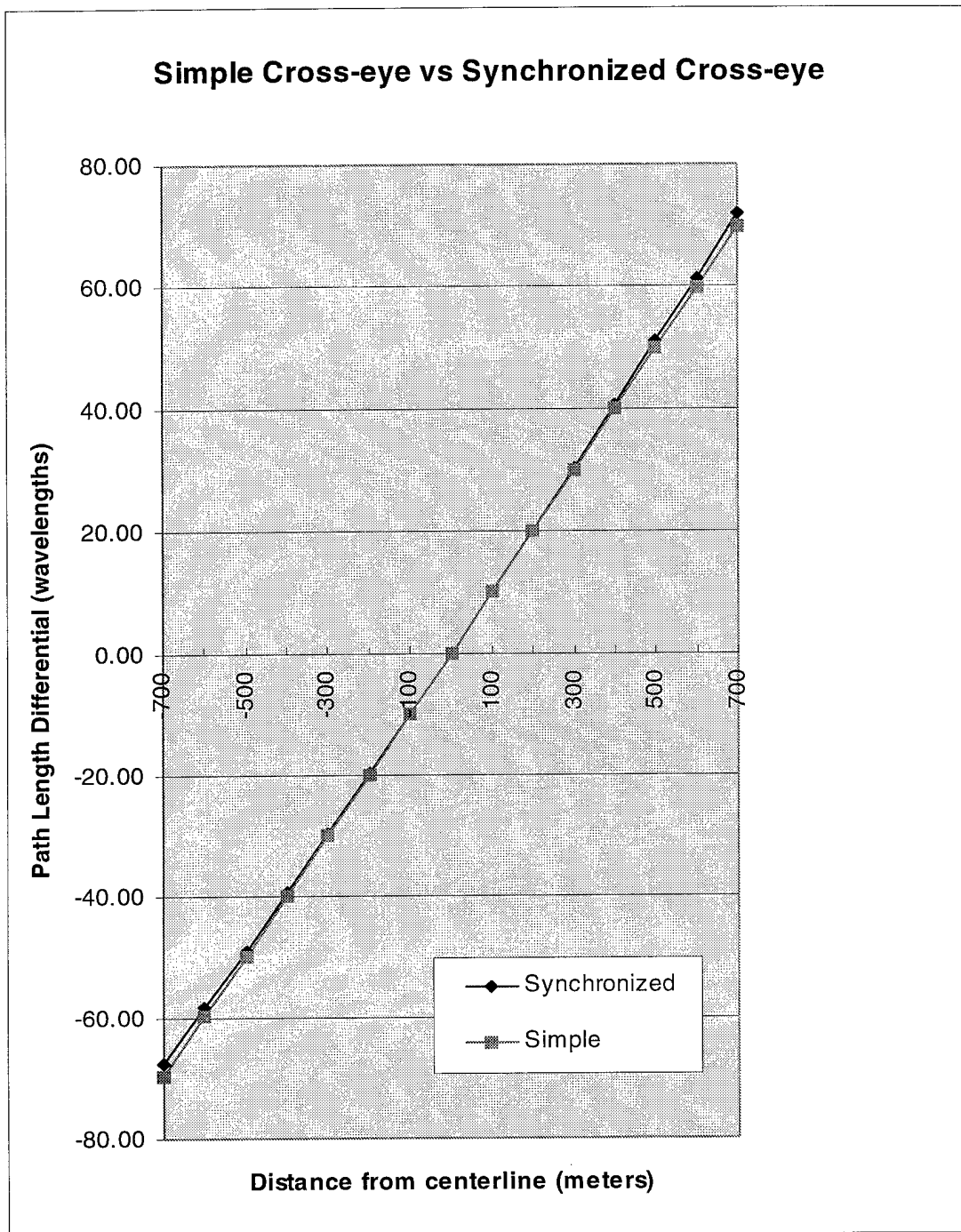

Figure 5-2 Synchronized vs Simple Cross-Eye Comparison

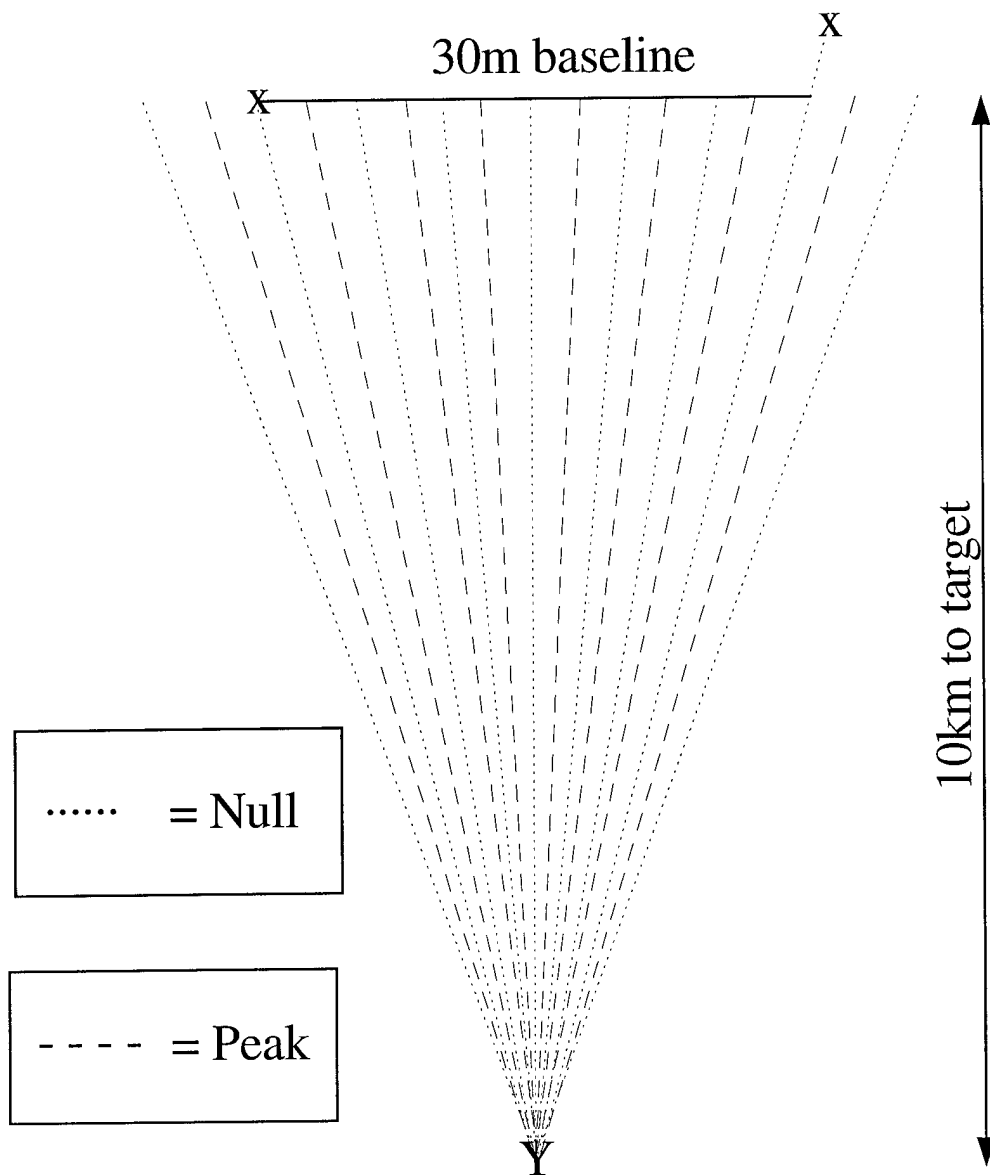

Figure 5-3 Polar Mapping of Interferometric Pattern to Target at 10km Distance

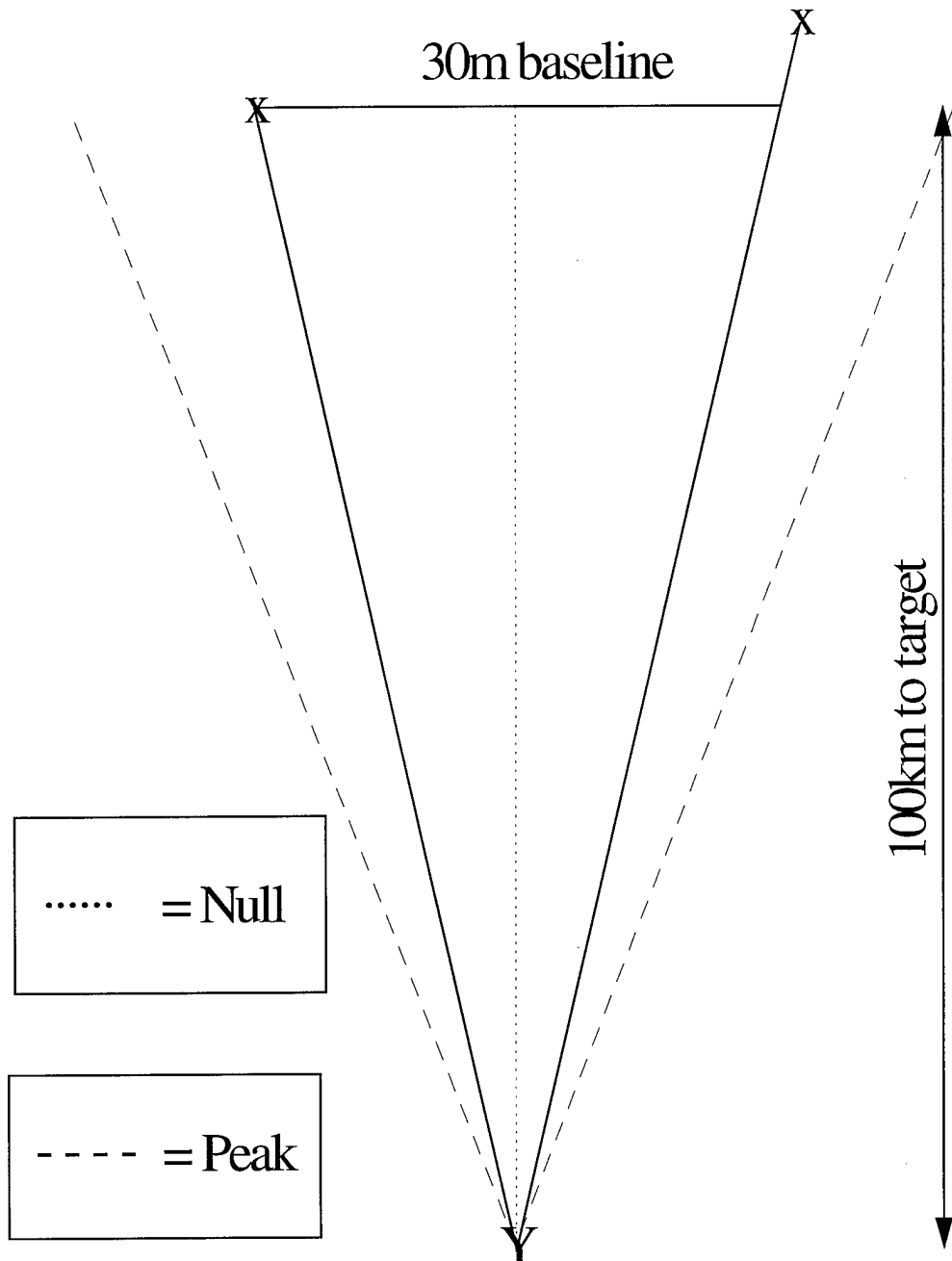

Figure 5-4 Polar Mapping of Interferometric Pattern to Target at 100km Distance

Conclusions

Given a pulse-to-pulse Radio Frequency (RF) agile threat, this thesis proposes a new ECM technique to protect an airborne platform, namely synchronized cross-eye. Synchronized cross-eye requires a low Radar Cross Section (RCS) platform that can “communicate” with the asset to be protected (share frequency and time of arrival information) that must be illuminated prior to the asset to be protected.

To synchronize both waveforms in frequency and time, thereby ensuring the proper interferometric pattern is generated (phase interaction between the two sources) at the threat radar, the low RCS source shifts the illuminating waveform by 180° in phase and two times Δ Doppler (the difference in Doppler frequencies of the two sources as seen by the threat) and imposes a time delay equal to two times the Time Difference Of Arrival (TDOA) of the illuminating waveform on the two sources. This waveform covers the skin return of the asset to be protected in time and frequency while preserving the proper phase cancellation effects at the threat radar location. Frequency synchronization is difficult to implement and unnecessary in many instances. Assuming Doppler processing is not done prior to monopulse processing, the interferometric pattern is virtually unchanged at frequencies around 10 GHz.

Recommendations

A future threat that is pulse-to-pulse frequency agile presents a formidable foe. Development of such a threat, although expensive, would certainly not be wasteful. A postulated counter to the pulse-to-pulse frequency agile threat is synchronized cross-eye requiring specific geometrical constraints to effectively cover the skin return of the airborne platform to be protected. Specifically, the low RCS source must be illuminated first. If the future threat employs up front Doppler processing before monopulse processing, large variations in the carrier

frequency render cross-eye techniques impractical since both sources appear at different Doppler frequencies.

An Unmanned Aerial Vehicle (UAV) with a laser link to the host platform seems the most flexible way to implement synchronized cross-eye, allowing many head on profiles with the UAV flying in front; moreover, current theory suggests that jamming performance increases as a function of source separation as long as both sources stay within the antenna beamwidth. The UAV implementation makes large source separation distances practical.

Synchronized cross-eye suffers from the fundamental limitation of all cross-eye techniques, the inability to defeat a bistatic threat. A bistatic pulse-to-pulse RF agile threat would present an even more formidable foe and seem worthy of development. Any pulse-to-pulse RF agile threat that separating targets by Doppler frequency prior to monopulse processing will significantly degrade synchronized cross-eye jamming performance.

Bibliography

- Boyd, J. A., Electronic Countermeasures, Peninsula Publishing, Dos Altos, CA, 1965 (pages 14-48).
- Barton, David K., Modern Radar System Analysis, Artech House Inc., Norwood, MA, 1988 (pages 115-120).
- Van Brundt, Leroy B., Applied ECM Vol. I, EW Engineering Inc., Dunn Loring, VA, 1978 (pages 555-576).
- Vakin, S. A. and Shustov, L. N., Principles of Jamming and Electronic Reconnaissance, DTIC, Ft. Belvior, VA, 1969.
- Leonov, A. I. and Fomachev, K. I., Monopulse Radar, DTIC, Ft. Belvior, VA, 1970.
- Sherman, Samuel M., Monopulse Principles and Techniques, Artech House, Norwood, MA, 1984.
- Golden, August Jr., Radar Electronic Warfare, AIAA Inc., NY, NY, 1987.
- Schleher, Curtis D. , Introduction to Electronic Warfare, Artech House Inc., Dedham, MA, 1986 (pages 158-159/248-249).

Vita

Lt Gregory J. Meyer was born on [REDACTED] in [REDACTED]. He graduated from Colerain High School in 1982 and entered The Ohio State University where he earned a Bachelor of Science Degree in Electrical Engineering in March 1987. He worked for two years as a control system design engineer on the Electronic Control Unit (ECU) for the stealth bomber at Allied Signal Aerospace in Phoenix, Arizona and as a control systems design engineer on the Full Authority Digital Electronic Control (FADEC) for the CFM/CF6 family of commercial jet engines at General Electric Evendale Engine Assembly until he attended and graduated Officer Training School in May of 1994.

His first assignment was at Eglin AFB as an Electronic Combat Systems Engineer at the 53rd Wing (previously the Air Warfare Center) in advanced programs where he coordinated the only two live firings of foreign Surface-to-Air Missile Systems in the continental US against US airborne countermeasures. He earned his Master of Business Administration at the University of West Florida while stationed at Eglin AFB and entered the Graduate School of Engineering, Air Force Institute of Technology, in May 1996. Lt Meyer is moving to San Antonio after graduation to work at the Air Force Information Warfare Center (AFIWC) at Kelly AFB.

Permanent Address: [REDACTED]

REPORT DOCUMENTATION PAGE			Form Approved OMB No. 0704-0188	
Public reporting burden for this collection of information is estimated to average 1 hour per response, including the time for reviewing instructions, searching existing data sources, gathering and maintaining the data needed, and completing and reviewing the collection of information. Send comments regarding this burden estimate or any other aspect of this collection of information, including suggestions for reducing this burden, to Washington Headquarters Services, Directorate for Information Operations and Reports, 1215 Jefferson Davis Highway, Suite 1204, Arlington, VA 22202-4302, and to the Office of Management and Budget, Paperwork Reduction Project (0704-0188), Washington, DC 20503.				
1. AGENCY USE ONLY (Leave blank)	2. REPORT DATE December 1997	3. REPORT TYPE AND DATES COVERED Master's Thesis		
4. TITLE AND SUBTITLE USING CROSS-EYE TECHNIQUES TO COUNTER THE RADIO FREQUENCY AGILE MONOPULSE PROCESSING			5. FUNDING NUMBERS	
6. AUTHOR(S) Gregory J. Meyer, First Lieutenant, USAF				
7. PERFORMING ORGANIZATION NAME(S) AND ADDRESS(ES) Air Force Institute of Technology 2750 P Street WPAFB OH 45433-7765			8. PERFORMING ORGANIZATION REPORT NUMBER AFIT/GE/ENG/97D-15	
9. SPONSORING/MONITORING AGENCY NAME(S) AND ADDRESS(ES) WL/AAMW 2241 Avionics Circle WPAFB, OH 45433-7318			10. SPONSORING/MONITORING AGENCY REPORT NUMBER	
11. SUPPLEMENTARY NOTES				
12a. DISTRIBUTION AVAILABILITY STATEMENT Approved for public release; distribution unlimited			12b. DISTRIBUTION CODE	
13. ABSTRACT (Maximum 200 words) The purpose of this research was to evaluate how current cross-eye techniques protect an airborne platform versus a pulse-to-pulse Radio Frequency (RF) agile monopulse processing threat and, if necessary, develop a new cross-eye technique to counter this threat. This research evaluates how both current retrodirective cross-eye techniques and an original technique, namely synchronized cross-eye, hide the true skin return in the time and frequency domain while preserving the necessary phase interferometric effects at the threat radar location. Existing retrodirective cross-eye techniques are inadequate to counter the RF agile threat due to propagation delays. Using modeling and simulation, the research shows that geometrically dependent parameters are virtually constant on a pulse-to-pulse basis. If a low Radar Cross Section source can be deployed and, given that it is illuminated first by the threat radar, cross-eye jamming waveforms at the threat can hide the skin return in time and reproduce the necessary phase interferometric pattern, but small frequency differences between the two jamming sources occur at the threat radar location. Fortunately, these differences can only be detected if the threat employs up-front Doppler processing. Monopulse processing radars are a true threat to airborne platforms. Existing countermeasure techniques may not be able to deal with a monopulse processing radar with random, pulse-to-pulse Radio Frequency (RF) agility. This thesis examines the effects current cross-eye techniques have against RF agile threats and investigates an alternative form of cross-eye, synchronized cross-eye, to counter RF agile threats.				
14. SUBJECT TERMS Cross-Eye Jamming, Monopulse Processing, Radio Frequency (RF) Agility, Synchronized Cross-Eye, Phase Interferometric Patterns, Doppler Processing			15. NUMBER OF PAGES 47	
			16. PRICE CODE	
17. SECURITY CLASSIFICATION OF REPORT UNCLASSIFIED	18. SECURITY CLASSIFICATION OF THIS PAGE UNCLASSIFIED	19. SECURITY CLASSIFICATION OF ABSTRACT UNCLASSIFIED	20. LIMITATION OF ABSTRACT UL	