

Air Force Institute of Technology

**AFIT Scholar**

---

Theses and Dissertations

Student Graduate Works

---

3-2000

## Chemical Mechanical Polishing Optimization for 4H-SiC

Craig L. Neslen

Follow this and additional works at: <https://scholar.afit.edu/etd>



Part of the [Materials Science and Engineering Commons](#)

---

### Recommended Citation

Neslen, Craig L., "Chemical Mechanical Polishing Optimization for 4H-SiC" (2000). *Theses and Dissertations*. 4836.

<https://scholar.afit.edu/etd/4836>

This Thesis is brought to you for free and open access by the Student Graduate Works at AFIT Scholar. It has been accepted for inclusion in Theses and Dissertations by an authorized administrator of AFIT Scholar. For more information, please contact [AFIT.ENWL.Repository@us.af.mil](mailto:AFIT.ENWL.Repository@us.af.mil).



**CHEMICAL MECHANICAL POLISHING  
OPTIMIZATION FOR 4H-SiC**

THESIS

Craig L. Neslen, USAF

AFIT/GMS/ENP/00M-02

**DEPARTMENT OF THE AIR FORCE  
AIR UNIVERSITY**

**AIR FORCE INSTITUTE OF TECHNOLOGY**

---

**Wright-Patterson Air Force Base, Ohio**

APPROVED FOR PUBLIC RELEASE; DISTRIBUTION UNLIMITED.

**DTIC QUALITY INSPECTED 4**

20001113 026

The views expressed in this thesis are those of the author and do not reflect the official policy or position of the United States Air Force, Department of Defense, or the U. S. Government.

AFIT/GMS/ENP/00M-02

CHEMICAL MECHANICAL POLISHING  
OPTIMIZATION FOR 4H-SiC

THESIS

Presented to the Faculty

Department of Physics

Graduate School of Engineering and Management

Air Force Institute of Technology

Air University

Air Education and Training Command

In Partial Fulfillment of the Requirements for the  
Degree of Master of Science in Materials Engineering

Craig L. Neslen, B.S.

Captain, USAF

March 2000

APPROVED FOR PUBLIC RELEASE; DISTRIBUTION UNLIMITED.

CHEMICAL MECHANICAL POLISHING  
OPTIMIZATION FOR 4H-SiC

Craig L. Neslen  
Captain, USAF

Approved:

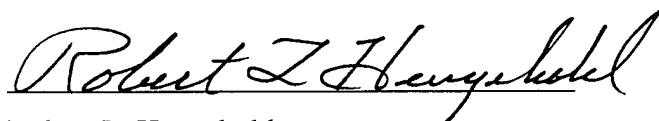

Robert L. Hengehold  
Chairman, Advisory Committee

7 Mar '00

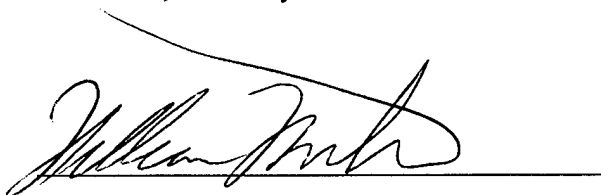

William C. Mitchel  
Member, Advisory Committee

7 Mar 00

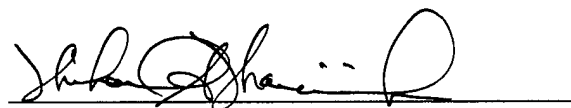

Michael A. Marciniak, Lieutenant Colonel, USAF  
Member, Advisory Committee

7 Mar 00

## Acknowledgments

I would like to thank Robert Bertke for the many hours he spent training me in the methods of Chemical Mechanical Polishing. His years of expertise were invaluable to me when data wasn't what was expected. I also want to thank Jeff Brown for his help with AFM measurements. He was extremely instrumental in helping avoid some potential roadblocks. Thanks are also due to Jerry Landis who provided the expertise and time to perform reactive ion etching on the wafer surfaces.

I want to thank Dr. William Mitchel for supplying practice SiC wafers which allowed me to come up to speed on CMP techniques and for the Cree samples used in this study. I am also grateful to my thesis advisor, Dr. Robert Hengehold who gave advice that forced me to reevaluate key polishing parameters and was essential to the success of this research and to LtCol Michael Marciniak who helped identify possible problems areas.

Finally, I extend my appreciation and love to my extremely supportive wife, Dawn and my three beautiful daughters, Kiera, Kelsey, and Brianna. Dawn has now supported me through a Bachelor's and Master's degree and I'm extremely grateful to her. Without them, life is not nearly as enjoyable.

# Table of Contents

Acknowledgments.....	iii
Table of Contents.....	iv
List of Figures.....	vi
List of Tables.....	x
Abstract.....	xi
I. Introduction.....	1
Material Properties and Applications.....	1
II. CMP Theory and Methodology.....	6
Polishing Slurry Chemical Composition.....	7
Slurry pH.....	8
Polishing Temperature.....	9
Polishing Pad Speed and Applied Pressure.....	12
Study Parameters.....	14
Removal Rate Determination.....	14
III. Experimental Procedures.....	23
Sample Description.....	23
Wafer Defects.....	24
Wafer Residual Scratches.....	27
Sample Mounting.....	30
Sample Polishing.....	31
IV. Experimental Results.....	39
Preliminary Study.....	39
Temperature Study.....	40
Slurry pH Study.....	44
Pressure Study.....	52
Rotational Speed Study.....	58
Optimized Study.....	63
V. Conclusion and Recommendations.....	70
VI. Appendices.....	74
Appendix A: Reactive Ion Etch Procedure.....	74
Appendix B: Wafer Attachment Procedure.....	75
Appendix C: Wafer Cleaning Procedure.....	76

Appendix D: Wafer 5 Temperature Study (23°C) .....	77
Appendix E: Wafer 5 Temperature Study (65°C).....	78
Appendix F: Wafer 5 pH 11 Study at 60rpm.....	79
Appendix G: Wafer 5 90rpm Study at 5 lb/in <sup>2</sup> .....	80
Appendix H: Wafer 6 pH 11 Study at 90rpm .....	81
Appendix I: Wafer 6 pH 12 Study at 90rpm.....	82
Appendix J: Wafer 6 - 7 lb/in <sup>2</sup> Study at 90rpm .....	83
Appendix K: Wafer 6 - 9 lb/in <sup>2</sup> Study at 90rpm .....	84
Appendix L: Wafer 6 - 11 lb/in <sup>2</sup> Study at 90rpm.....	85
Appendix M: Wafer 6 - 120rpm Study at 5 lb/in <sup>2</sup> .....	86
Appendix N: Wafer 6 - 150rpm Study at 5 lb/in <sup>2</sup> .....	87
Appendix O: Wafer 6 - 180rpm Study at 5 lb/in <sup>2</sup> .....	88
Appendix P: Wafer 6 - Final 180rpm Study at 5 lb/in <sup>2</sup> .....	88
 Bibliography .....	 90
 Vita.....	 92



# List of Figures

Figure 1: Polishing Pad Fibers.....	11
Figure 2: 1000x Photograph of Trench 4 Pre-Polish Condition .....	19
Figure 3: 1000x Photograph of Trench 4 Post 1-Hour Polish Condition .....	19
Figure 4: 1000x Photograph of Trench 4 Post 1.5 Hour Polish Condition.....	19
Figure 5: 1000x Photograph of Trench 4 Post 2 Hour Polish Condition.....	19
Figure 6: Wafer Defect Regions and Trench Location.....	25
Figure 7: 12.5x Photograph of Wafer 6 Minor Flat.....	26
Figure 8: 100x Photograph of Wafer 6 Region 1.....	26
Figure 9: 100x Photograph of Wafer 6 Region 2.....	26
Figure 10: 100x Photograph of Wafer 6 Region 3.....	26
Figure 11: 1000x Photograph of Wafer 2 As Received Surface Scratches .....	27
Figure 12: 1000x Photograph of Wafer 4 As Received Surface Scratches .....	27
Figure 13: 1000x Photograph of Wafer 5 As Received Surface Scratches .....	27
Figure 14: 1000x Photograph of Wafer 6 As Received Surface Scratches .....	27
Figure 15: 1000x Photograph of Wafer 3, Trench 4 Surface Scratches .....	28
Figure 16: 1000x Photograph of Wafer 4, Trench 2 Surface Scratches .....	28
Figure 17: 1000x Photograph of Wafer 5, Trench 2 Surface Scratches .....	28
Figure 18: 1000x Photograph of Wafer 6, Trench 2 Surface Scratches .....	28
Figure 19: AFM Amplitude Image of Wafer 6 As Received Surface Scratches.....	29
Figure 20: Experimental Setup .....	32
Figure 21: Wafer Motion Across Pad Surface.....	34

Figure 22: Temperature Study at 60rpm and 5 lb/in <sup>2</sup> .....	41
Figure 23: 1000x Pre-Polish Photograph of Wafer 5.....	42
Figure 24: 1000x Post 1-Hour Polish Photograph at 25°C, 5 lb/in <sup>2</sup> and 60rpm .....	42
Figure 25: 1000x Post 2-Hour Polish Photograph at 25°C, 5 lb/in <sup>2</sup> and 60rpm .....	42
Figure 26: 1000x Post 3-Hour Polish Photograph at 25°C, 5 lb/in <sup>2</sup> and 60rpm .....	42
Figure 27: 1000x Pre-Polish Photograph of Wafer 5.....	43
Figure 28: 1000x Post 1-Hour Polish Photograph at 65°C, 5 lb/in <sup>2</sup> and 60rpm .....	43
Figure 29: 1000x Post 2-Hour Polish Photograph at 65°C, 5 lb/in <sup>2</sup> and 60rpm .....	43
Figure 30: 1000x Post 3-Hour Polish Photograph at 65°C, 5 lb/in <sup>2</sup> and 60rpm .....	43
Figure 31: Slurry pH Study at 5 lb/in <sup>2</sup> and 60rpm.....	45
Figure 32: 1000x Pre-Polish Photograph of Wafer 5.....	46
Figure 33: 1000x Post 1-Hour Polish Photograph at 11pH, 5 lb/in <sup>2</sup> and 60rpm .....	46
Figure 34: 1000x Post 2-Hour Polish Photograph at 11pH, 5 lb/in <sup>2</sup> and 60rpm .....	46
Figure 35: 1000x Post 3-Hour Polish Photograph at 11pH, 5 lb/in <sup>2</sup> and 60rpm .....	46
Figure 36: Slurry pH Study at 5 lb/in <sup>2</sup> and 90rpm.....	47
Figure 37: 1000x Pre-Polish Photograph of Wafer 5.....	48
Figure 38: 1000x Post 1-Hour Polish Photograph at 9.9pH, 5 lb/in <sup>2</sup> and 90rpm .....	48
Figure 39: 1000x Post 2-Hour Polish Photograph at 9.9pH, 5 lb/in <sup>2</sup> and 90rpm .....	48
Figure 40: 1000x Post 3-Hour Polish Photograph at 9.9pH, 5 lb/in <sup>2</sup> and 90rpm .....	48
Figure 41: 1000x Pre-Polish Photograph of Wafer 6.....	49
Figure 42: 1000x Post 1-Hour Polish Photograph at 11pH, 5 lb/in <sup>2</sup> and 90rpm .....	49
Figure 43: 1000x Post 2-Hour Polish Photograph at 11pH, 5 lb/in <sup>2</sup> and 90rpm .....	49
Figure 44: 1000x Post 3-Hour Polish Photograph at 11pH, 5 lb/in <sup>2</sup> and 90rpm .....	49

Figure 45: 1000x Pre-Polish Photograph of Wafer 6.....	50
Figure 46: 1000x Post 1-Hour Polish Photograph at 12pH, 5 lb/in <sup>2</sup> and 90rpm .....	50
Figure 47: 1000x Post 2-Hour Polish Photograph at 12pH, 5 lb/in <sup>2</sup> and 90rpm .....	50
Figure 48: 1000x Post 3-Hour Polish Photograph at 12pH, 5 lb/in <sup>2</sup> and 90rpm .....	50
Figure 49: Dry Path Formation on Polishing Pad.....	53
Figure 50: Pressure Study at 9.9pH and 90rpm .....	53
Figure 51: 1000x Pre-Polish Photograph of Wafer 6.....	55
Figure 52: 1000x Post 1-Hour Polish Photograph at 9.9pH, 7 lb/in <sup>2</sup> and 90rpm .....	55
Figure 53: 1000x Post 2-Hour Polish Photograph at 9.9pH, 7 lb/in <sup>2</sup> and 90rpm .....	55
Figure 54: 1000x Post 3-Hour Polish Photograph at 9.9pH, 7 lb/in <sup>2</sup> and 90rpm .....	55
Figure 55: 1000x Pre-Polish Photograph of Wafer 6.....	56
Figure 56: 1000x Post 1-Hour Polish Photograph at 9.9pH, 9 lb/in <sup>2</sup> and 90rpm .....	56
Figure 57: 1000x Post 2-Hour Polish Photograph at 9.9pH, 9 lb/in <sup>2</sup> and 90rpm .....	56
Figure 58: 1000x Post 3-Hour Polish Photograph at 9.9pH, 9 lb/in <sup>2</sup> and 90rpm .....	56
Figure 59: 1000x Pre-Polish Photograph of Wafer 6.....	57
Figure 60: 1000x Post 1-Hour Polish Photograph at 9.9pH, 11 lb/in <sup>2</sup> and 90rpm .....	57
Figure 61: 1000x Post 2-Hour Polish Photograph at 9.9pH, 11 lb/in <sup>2</sup> and 90rpm .....	57
Figure 62: 1000x Post 3-Hour Polish Photograph at 9.9pH, 11 lb/in <sup>2</sup> and 90rpm .....	57
Figure 63: Pad Speed Study at 5 lb/in <sup>2</sup> .....	59
Figure 64: 1000x Pre-Polish Photograph of Wafer 5.....	60
Figure 65: 1000x Post 1-Hour Polish Photograph at 5 lb/in <sup>2</sup> and 120rpm .....	60
Figure 66: 1000x Post 1.5-Hour Polish Photograph at 5 lb/in <sup>2</sup> and 120rpm .....	60
Figure 67: 1000x Post 2-Hour Polish Photograph at 5 lb/in <sup>2</sup> and 120rpm .....	60

Figure 68: 1000x Pre-Polish Photograph of Wafer 5.....	61
Figure 69: 1000x Post 30 Minute Polish Photograph at 5 lb/in <sup>2</sup> and 150rpm .....	61
Figure 70: 1000x Post 60 Minute Polish Photograph at 5 lb/in <sup>2</sup> and 150rpm .....	61
Figure 71: 1000x Post 90 Minute Polish Photograph at 5 lb/in <sup>2</sup> and 150rpm .....	61
Figure 72: 1000x Pre-Polish Photograph of Wafer 5.....	62
Figure 73: 1000x Post 30 Minute Polish Photograph at 5 lb/in <sup>2</sup> and 180rpm .....	62
Figure 74: 2000x Post 30 Minute Polish Photograph at 5 lb/in <sup>2</sup> and 150rpm .....	62
Figure 75: 1000x Post 60 Minute Polish Photograph at 5 lb/in <sup>2</sup> and 150rpm .....	62
Figure 76: AFM Amplitude Image of Wafer 5 After 3μm Diamond Polish .....	65
Figure 77: Final Pad Speed Study at 5 lb/in <sup>2</sup> and 180 rpm.....	66
Figure 78: 1000x Pre-Polish Photograph of Wafer 5.....	67
Figure 79: 1000x Post 30 Minute Polish Photograph at 5 lb/in <sup>2</sup> and 180rpm .....	67
Figure 80: 1000x Post 60 Minute Polish Photograph at 5 lb/in <sup>2</sup> and 150rpm .....	67
Figure 81: 1000x Post 90 Minute Polish Photograph at 5 lb/in <sup>2</sup> and 150rpm .....	67
Figure 82: AFM Amplitude Image of Wafer 5 After 3μm After 3 Hour CMP .....	68

## **List of Tables**

Table 1: Wafer Cleaning Procedure Effectiveness Analysis .....	36
Table 2: Experiment Polishing Parameters Summary .....	38
Table 3: Preliminary Study Results .....	39

## Abstract

Scratch free surfaces are required for substrates used in epitaxial growth. Silicon carbide (SiC) is a substrate material that is used in the epitaxial growth of SiC, GaN, and InGaN electronic devices. Preliminary chemical mechanical polishing (CMP) studies of 1 3/8" 4H-SiC wafers were performed in an attempt to identify the polishing parameter values that result in a maximum material removal rate and thus reduce substrate polishing time. Previous studies reported increased material removal rates associated with increasing polishing temperature, slurry pH, pressure, and polishing pad speed. In the current study, the effects of temperature, slurry pH, polishing pressure, and polishing pad speed were examined independently while keeping other polishing parameters constant. Material removal rates were determined using pre and post-polish wafer mass measurements. Photographs at specific wafer locations were obtained before and after each polishing period and compared to calculated removal rates.

The current study indicated that different temperatures affect the removal rate by changing pad fiber dynamic shear modulus and not by altering the chemical reaction rate between the polishing slurry and wafer surface atoms. Also, in contradiction to other studies, a decrease in material removal was observed for increasing slurry pH levels. Increased applied pressure resulted in higher removal rates and unwanted polishing pad damage. Higher pad rotational speeds produced non-linear increases in material removal rates and appeared to have the greatest impact on material removal rates. High pressures and rotational speeds introduced variability and randomness in the calculated removal rates.

# Chemical Mechanical Polishing Optimization for 4H-SiC

## I. Introduction

Silicon carbide (SiC) is a semiconductor material that has the potential to be used in a variety of military applications due to many of its material properties. SiC is a wide bandgap semiconductor with excellent thermal conductivity values that vary with polytype and dopant concentration (Harris, 1995:5). In addition, it has outstanding mechanical and wear properties, which allow it to be used in a variety of demanding environments. It is also extremely resilient to radiation and chemical attack at room temperature. These properties make silicon carbide an attractive option for semiconductor device applications in many caustic environments as well as in space.

Silicon carbide can exist in over 200 different crystal structure modifications or polytypes. Polytype 3C, which is a cubic crystal structure, and two hexagonal crystal structures, 4H and 6H, are common SiC polytypes used in advanced technology semiconductor devices. In particular, 4H- and 6H-SiC are favorites among semiconductor device manufacturers due to the commercial availability of low defect density crystals (Yasseen, 1999:327).

### Material Properties and Applications

Although silicon carbide has many polytypes, the general atomic structure of SiC consists of layers of silicon and carbon atoms bonded tetrahedrally and stacked on each other. The various polytypes arise from the different orders in which the layers are arranged.

4H-SiC has an energy bandgap of approximately 3.285 eV at temperatures less than 5K (Harris, 1995:31). Typical intrinsic silicon and germanium bandgap values are 1.1 and 0.7 eV respectively. The higher bandgap energy of SiC results in a higher operating temperature without intrinsic electron excitation. Coupled with the fact that SiC has thermal conductivity values that can exceed that of copper yields the conclusion that SiC devices are capable of operating in a high temperature environment. Typical silicon devices have operating temperatures as high as 150°C, while SiC devices have shown the ability to operate nominally at temperatures as high as 650°C (Neudek).

The Air Force has a need for semiconductors that are capable of nominal operation at higher temperatures for many applications (Neudek). Many military aircraft utilize GaAs microwave devices for electronic communication and radar systems. Although GaAs has been useful for devices in the past, current military aircraft systems goals involve microwave devices capable of operating at higher temperatures and power levels. Silicon carbide devices can meet both of these Air Force requirements.

In addition to radar and communications systems, Air Force aircraft could reap significant aircraft weight and reliability benefits from the development of high temperature electronic devices. Current military aircraft engine electronic control systems are typically housed in a cooled compartment with wiring connecting the control electronics to the various components of the engine. Advanced SiC electronics would drastically reduce weight and increase reliability because the electronics could be housed in the engine with little wiring required. The Air Force has estimated that advanced SiC control electronics implemented on an F-16 fighter would result in a weight loss of



hundreds of pounds (Neudeck). Also, aircraft reliability would increase since many hours of aircraft downtime and maintenance are attributable to worn wiring and bad wire connections. In addition to aircraft benefits, high power SiC devices would result in substantial weight savings on military satellites. Advanced SiC devices do not require the heavy cooling systems and thermal shielding with which current spacecraft electronic devices operate. Reductions in satellite cooling and heat shielding systems would result in reduced satellite weight, higher reliability, increased space for additional satellite functional devices and significant launch cost savings.

Besides its ability to operate at elevated temperatures, SiC is also significantly less susceptible to radio frequency (RF) interference, radiation damage, and chemical attack than silicon. Past research conducted by the U.S. Army Research Laboratory and the NASA Lewis Research Center found that the use of SiC diodes reduced RF interference by a factor of 10 in comparison to silicon based diodes (Neudeck). Also, as of only five years ago, no known aqueous solution existed that chemically attacked SiC at room temperature, although SiC can be etched using molten salts such as NaOH or KOH at 500°C. Plasma and reactive ion etching techniques can also be used although the results from these techniques are not always conducive to quality device fabrication (Sugiura et al., 1986:349) (Palmour and Davis, 1986:590). These material properties make SiC an attractive option to Si and GaAs electronics systems used in the space environment.

Many of the advanced technology electronic devices are possible due to advances in various epitaxial methods. Molecular beam epitaxy, liquid phase epitaxy and vapor

phase epitaxy are all methods of epitaxial growth. Each of these methods makes use of a highly polished wafer frequently termed a substrate. To prevent excess mechanical stress, the substrate material should have an atomic lattice constant that is very similar to the device material. Therefore, SiC substrates are commonly used to grow SiC, GaN, and InGaN devices. Just as it is important to grow semiconductor wafers beginning with a 'perfect' seed crystal, so it is imperative to begin epitaxial growth with a 'smooth', defect free surface. This is especially true in the case of SiC. Current SiC wafers contain defects called micro-pipes. Micro-pipes are extremely small material voids that can tunnel through the entire thickness of a wafer. Although major improvements have been made to reduce the number of micro-pipes in SiC crystals, their presence in current SiC crystals has not yet been completely eliminated. The removal of all other defects is important if a SiC wafer is to be used as a substrate in epitaxial growth. Defects or scratches on the substrate surface will propagate through the epitaxial growth process and result in a device which is unacceptable.

Chemical mechanical polishing is a polishing technique that can produce the high quality substrates needed to epitaxially grow advanced electronic devices. The goal of this study is to examine several CMP parameters and develop a preliminary set of polishing parameters that will minimize the time required to acquire a scratch free SiC surface. This first chapter has been an introduction and provides information regarding SiC material properties and specific Air Force applications for this research. Chapter II presents general CMP theory and introduces the reader to several CMP parameters believed to be crucial to the polishing process. In addition it discusses various methods of material removal rate determination and describes the method used during this

research. Chapter III provides information on the samples, equipment and experimental polishing techniques used during this research. Chapter IV presents the observed effects the several polishing parameters had on the polishing process. Finally, Chapter V is dedicated to a summary of the results and recommendations for future research.

## II. CMP Theory and Methodology

Chemical mechanical polishing (CMP) has not always been accepted as an effective method to acquire a highly polished semiconductor surface. Many semiconductor manufacturers were skeptical that CMP could produce a quality surface when the process was first introduced in the late 1960's and early 1970's. The attitudes of semiconductor manufacturers have changed in the past 30 years. Chemical mechanical polishing has quickly become an integral part of many device manufacturing processes. Chemical mechanical polishing is precisely what its name implies; it is the polishing of a semiconductor surface by chemical reactions between the wafer surface atoms and the polishing slurry and mechanical removal of the 'softened' semiconductor surface atoms by small particles suspended in the polishing slurry.

Obtaining an acceptable wafer surface involves many hours of polishing and introduces a considerable amount of cost into the wafer manufacturing process. Therefore, it is desirable to accelerate the polishing process by developing the optimum polishing conditions. There are many polishing parameters that affect the rate of material removal. Some of these parameters are: polishing slurry chemical composition, slurry particle type and percent content, slurry pH, polishing temperature, polishing pad type and pad condition, pad speed, and polishing pressure. Several of these parameters will be discussed in greater detail presently. Although a wealth of information exists on chemical mechanical polishing of silicon and germanium, very little has been published on silicon carbide. It is believed that limited data regarding CMP of SiC exists but has not been published because most of the research has been performed by companies that commercially sell CMP products.

## Polishing Slurry Chemical Composition

There is a myriad of possible chemical compositions that can be used to polish silicon carbide. In most documented cases, a solution with sub- $\mu\text{m}$  silica particles in suspension is used. Solutions such as this are termed colloidal silica polishing slurries and are readily available. One study (Zhou et al., 1997:L161) makes use of a diluted colloidal silica slurry called Nalco 2350. In this same study, the authors present a theory regarding the chemical reaction between the slurry and wafer surface atoms. According to the theory, the alkaline solution contains hydroxide ( $\text{OH}^-$ ) groups, which are free to bond with the single dangling electron of the surface silicon atom. The resulting dipole weakens the bonds between the surface silicon atom and the three carbon atoms. In addition, it allows oxygen molecules to form bonds with the surface silicon atoms, thereby forming  $\text{SiO}_2$  which is a considerably softer material than  $\text{SiC}$ . The atomic layer of  $\text{SiO}_2$  is subsequently removed by mechanical wear between the wafer surface and the silica particles and the next layer of silicon atoms is exposed to the polishing slurry. Pietsch (Pietsch et al., 1994:3115) and Trogolo (Trogolo and Rajan, 1994:4554) present similar theories with regard to chemical mechanical polishing of silicon. Although Zhou's theory could, in part, be correct, the theory fails to explain the mechanism for removal of the carbon atoms after the initial layer of silicon atoms is removed. Using the colloidal silica polishing slurry, Zhou reports a material removal rate of 1000 to 2000  $\text{\AA}/\text{hour}$  that is dependent upon other polishing parameters.

Although not specifically a polishing method, an additional means of obtaining a defect free surface is described in the literature. This study involved etching the  $\text{SiC}$  surface with hot hydrogen gas (Owman et al., 1996:391). In this study, 6H- $\text{SiC}$

was placed in a hot wall chemical vapor deposition reactor and hydrogen gas heated to 1,550°C flowed over the surface of the wafer for 30 minutes at atmospheric pressure. The heated hydrogen chemically reacted with the wafer surface and resulted in a smooth surface. Atomic force microscopy (AFM) discovered that the surface morphology consisted of a series of atomic terrace steps with the width of the steps approximately 1,500Å and a height of about 15Å. Cornell University appears to have developed a method to remove the terraces from the wafer surface (Port, 1996:82). Although the results of the technique used by Owman are promising, the required equipment to study such a technique was not available.

### **Slurry pH**

Besides the actual chemical composition of the polishing slurry, several researchers have observed a material removal rate dependence on slurry pH. Zhou reported that the removal rate increased with increasing slurry pH levels. In this report, pH levels as high as 11 were examined with the best results occurring at this highest value. The theory behind this observation is again due to the presence of hydroxide (OH<sup>-</sup>) ions. As the pH increases, so does the availability of hydroxide ions. This results in an increased reaction rate between the surface silicon atoms and the increasing number of available hydroxide ions. Thus, theoretically, the higher the slurry pH level, the greater the probability of bonding between hydroxides and silicon atoms which results in an increase in removal rate.

Pietsch makes a similar observation after polishing silicon and presents data describing material removal rate as a function of slurry pH level. This report indicates that as slurry pH increases up to about 11.5, material removal rate also increases.

However, further increases in the slurry pH actually result in a decrease in removal rate. Neither article specified how the slurry pH was varied, although, it can be easily increased by adding NaOH or KOH. In a separate article, Pietsch (Pietsch et al., 1995:1652) makes the claim that slurry pH values are the most important CMP parameter to consider when attempting to increase material removal rate. Higher slurry pH levels are difficult to maintain due to the chemical reaction of CO<sub>2</sub> in the air with the hydroxide groups in the slurry.

### **Polishing Temperature**

Two different theories were discovered in the literature regarding the effects temperature has on the polishing process. In addition to observing the effects of several slurry pH levels, Zhou also briefly examined temperature effects. Using pre-heated slurry and an infrared lamp, Zhou claims to have polished at an elevated temperature of approximately 55°C. It was at the elevated temperature of 55°C and a slurry pH level of 11 that produced the highest material removal rate of approximately 2,000Å/hour presented in this report.

The report concluded that the increased polishing temperature improved the material removal rate by increasing the reaction rate between the hydroxide groups in the slurry and the silicon dangling electrons. From chemical reaction kinetics, we learn that most reactions can be accelerated with increased temperatures (Ragone, 1995:205). Arrhenius performed research in the latter part of the nineteenth century and developed the following relationship:

$$\text{Reaction Rate} \propto \text{Exp}(-E^*/R*T)$$

where  $E^*$  is the reaction activation energy,  $R$  is the universal gas constant and  $T$  is the temperature. Thus, as the temperature increases, so does the reaction rate. Zhou concluded that this increase in reaction rate significantly affected the overall material removal rate.

A second theory regarding the effect temperature has on material removal rate is presented by Li (Li, 1995:601). In this study, two different pads from Rodel Products Incorporated were analyzed. The SUBA IV polishing pad fibers are made of a polyurethane impregnated polyester fabric. Rodel IC1000 pads are made from a microporous polyurethane material. The dynamic shear modulus of both pads was examined at temperatures between 30°C and 90°C at two different frequencies. It was discovered that the modulus of the SUBA IV pad decreased from about 43MPa at 30°C to about 29MPa at 90°C at a test frequency of 1Hertz. In contrast, the IC1000 pad modulus decreased from about 90MPa at 30°C to about 32MPa at 90°C with the same test frequency. Thus, increased temperatures had a large effect on the dynamic shear modulus of the IC1000 pad and a much smaller impact on the modulus of the SUBA IV pad.

In addition to this study, Li presents a theory regarding the microscopic mechanism of wafer material removal. According to this report, the polishing pads have a surface roughness of about 20 $\mu$ m while the silica particles responsible for mechanical removal of the material have a diameter as small as 20nm. Thus, the valleys produced by the pad fibers are as much as 1000 times larger than the silica particles. Figure 1



illustrates a simplified picture of the semiconductor wafer interacting with the pad fibers and silica particles in the polishing slurry.

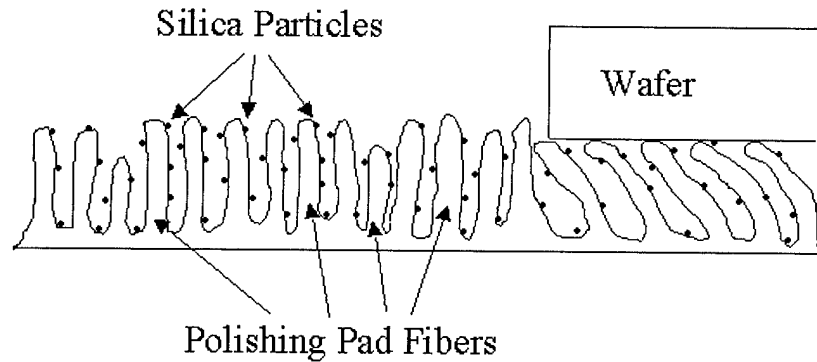

Figure 1: Magnified view of typical polishing pad fibers with smaller silica particles providing the mechanism for mechanical removal of the wafer surface.

For a given pressure, the wafer compresses the pad fibers and the silica particles interact mechanically with the wafer surface. Note that many silica particles at the bottom of the valleys formed by the pad fibers do not directly interact with the wafer surface. Li theorizes that if the wafer interacts with more silica particles, the material removal rate will increase. Higher temperatures reduce the dynamic shear modulus of the fibers and allow the wafer to press deeper into the pad. Thus, Li theorizes that pad fiber temperature dependencies affect removal rates as opposed to the chemical reaction rate temperature dependence as claimed by Zhou. Li presents removal rate data that shows little to no temperature dependence using the SUBA IV pad but a significant temperature dependence using the IC1000 pad. The removal rate data Li presents supports his hypothesis.

### Polishing Pad Speed and Applied Pressure

Many documents can be found that discuss the effects of polishing pad speed and applied pressure on material removal rate. In regard to polishing silicon, experimental data led to the development of the Preston equation (Tseng et al., 1997:L15). The Preston equation has been used in past years as a tool to estimate material removal rates and is given by:

$$Removal\ Rate = k_p * P * V$$

where  $k_p$  is the Preston coefficient,  $P$  is the applied pressure, and  $V$  is the relative velocity of the wafer with respect to the polishing pad. Thus, according to this equation, removal rate could be increased by increasing the polishing speed of the pad or the applied pressure.

Using the stress analysis and polishing model of others, Tseng derived another equation showing the dependency of removal rate on pressure and velocity. The Tseng equation is given by:

$$Removal\ Rate = M * P^{5/6} * V^{1/2}$$

where  $M$  is a constant depending on material properties, slurry concentration and chemical process dependencies,  $P$  is the applied pressure and  $V$  is the polishing velocity. In addition to its derivation, Tseng obtained experimental results from polishing  $SiO_2$  that compared well with the removal rate values given by the Tseng equation.

Additional subsequent work by Tseng was performed (Tseng et al., 1999:1952) in which Tseng develops yet another equation relating pressure and velocity to material removal rate. This modified equation is given by:

$$Removal\ Rate = k_c * P * V * Exp(-\beta * V)$$

where  $k_c$  is a removal rate weighting factor,  $P$  is the applied pressure,  $V$  is the velocity and  $\beta$  is a deterioration factor that describes polishing particle aggregation and abrasion degradation. With the development of this modified Tseng equation, Tseng performed experimental tests and compared analytical and experimental results using the Preston, Tseng and modified Tseng equations. He concluded that the Preston equation was inadequate to provide accurate removal rate estimates for varied pressures and polishing velocities. He also concluded that the Tseng equation and modified Tseng equation provided data in good agreement with experimentally determined material removal rates.

Doubtless, the attempts to derive these analytical relationships required a consideration of the dynamic effects of the polishing slurry. Indeed, the literature is rich with information on the effects lubrication dynamics has on the polishing process. Zhu (Zhu et al., 1999:848) performed tribochemical polishing of SiC in several oxidant solutions. Tribochemical polishing is different from CMP in that no abrasives are used in tribochemical polishing. Material is removed from the surface by friction stimulated chemical dissolution. Also, a smooth hard surface such as  $\text{Si}_3\text{N}_4$  or even cast iron is used to polish the semiconductor as opposed to a fibrous pad in chemical mechanical polishing. This study exposed the well known effects of hydro-planing. As the polishing velocity was increased, the material removal rate decreased due to the decreased contact between the polishing surface and the wafer.

In contrast to the Zhu's findings, Levert (Levert et al., 1998:593) and Tichy (Tichy et al., 1999:1523) obtained very different results after examining lubrication dynamics using a typical CMP pad. Both of these studies involved measuring the pressure experienced by the wafer at various points across the wafer surface. The

experiment was arranged in such a way as to allow pressure measurements to be made while polishing the wafer surface on the CMP pad. Surprisingly, instead of measuring a decrease in pressure across the wafer, both studies found an increase in pressure. This suction pressure under the wafer surface increased with increasing polishing velocities and caused the wafer to be pressed deeper into the polishing pad fibers. In addition, Tichy found that the pressure due only to applied weight on a stationary wafer and pad was greatest at the wafer edges. The suction pressure arising from polishing with a CMP pad at a given velocity is added to the static pressure to give a total polishing pressure.

### **Study Parameters**

After a review of the information available on CMP, the following polishing parameters appeared to have the greatest potential for optimizing wafer removal rates: slurry chemical composition, polishing temperature, slurry pH, polishing pressure, and pad speed. Although slurry chemical composition is believed to be an important polishing parameter, it was decided to exclude this parameter for this particular study due to possible long order lead times. This study will examine the general effects of polishing temperature, slurry pH level, applied pressure, and polishing speed. Although this study does not optimize all of the above parameters, it does provide insight that will prove valuable for future studies.

### **Removal Rate Determination**

In order to analyze the effectiveness of the various parameters in the polishing process, it was critical to use a method that would provide fairly accurate and repeatable values for wafer removal rate. Wafer removal rate has been determined using a variety of methods. Perhaps the easiest method to determine removal rate is to measure wafer

thickness before and after polishing. Several devices such as ADE's 6300 MicroSense and Keyence's LC-2400 Series Laser Displacement Meter, are commercially available and provide up to 0.01 micrometer resolution. Such a device would be more than adequate for measuring removal rates for silicon wafers which have reported removal rates as high as 120,000Å/hour. However, it was unknown if 0.01 micrometer resolution would be acceptable for silicon carbide polishing. In addition, such a device was not available for this particular study.

Another method of calculating wafer removal rates consists of using an indenting device to place a small indentation of known geometry onto the wafer surface. It is believed that Zhou made use of this technique for material removal rate calculations. After making the indentation, the diameter of the indentation is measured using optical microscopy. The sample is polished and the indentation diameter is again measured. With the difference in the diameter and geometry of the indentation known it is theoretically possible to calculate the difference that has occurred in the height of the indentation. This method makes use of the following two assumptions: wafer edges are not rounded during the polishing process and optical microscopy is sufficient to accurately determine the diameter of the indentation.

Rounding of the indentation edges would lead to calculated removal rate values that are theoretically lower than actual removal rates. Because rounding of an indentation edge would cause the indentation to appear larger in diameter, the calculated depth from this diameter would be larger and the calculated removal rate would be decreased. Observations made during this study that support the concept of edge rounding will be

presented later in this report. Besides edge rounding effects, this technique makes use of the assumption that the diameter of the indentation can be accurately measured using optical microscopy. Because removal rates achieved by polishing SiC are so small, it is necessary to have the capacity to accurately measure miniscule indentation diameter differences. Assuming an indentation width to depth ratio of 10 and an actual removal of 1,000 angstroms of material, it would be necessary to accurately measure to the nearest micro-meter. This would be difficult enough with sharp indentation edges at 1000x magnification. It becomes almost impossible when edge rounding blurs the indentation edges. Therefore, it is believed that this particular method is inadequate to accurately calculate material removal rates.

Another possible method to determine wafer removal rates was developed at the beginning of this study. This method involves etching several thin trenches near the middle of the wafer (Trench locations on the wafer are shown in Figure 6 on page 25). The depths of the trenches would be measured before and after each polish and the difference would be equivalent to the amount of material removed. The trenches were reactive ion etched using sulfur hexa-floride and were about 4mm long, 75 micro-meters wide and between 2 and 2.5 micro-meters deep. Appendix A describes the steps taken to etch the four trenches on the wafer surface. The plasma etch resulted in a damage layer at the bottom of the trenches that was of unknown thickness and was not removed after ultrasonic cleaning in a trichloroethylene bath.

After etching the four trenches and prior to polishing, trench width and depth measurements were made using two devices. A Dektak IIA and Tencor Alpha Step 250

were both used to make width and depth measurements and the results were compared for conformity. It was during stylus measurements that the damage layer at the bottom of the trenches was first noticed. The measuring stylus actually carved a visible path into the damage layer after several measurements were made at the same location.

Following stylus measurements, Wafer 2 was polished for one hour. Post polish stylus measurements were made and compared to the measurements taken before polishing. Although a damage layer of up to 1,500 angstroms is predicted (Harris, 1995:136), it is believed the damage layer in the four trenches extended much deeper because the stylus measurements after one hour of polishing indicated an increase in trench depth by approximately 2000 angstroms. Given this data, it became very apparent that this particular method of determining removal rate would not be effective.

Another factor that makes this method difficult to implement is the non-repeatability of the trench depth measurements. The plasma etch process produced a trench that was of non-uniform depth on the atomic scale. Depending on where the depth measurement was made, trench depths varied by as much as several thousand angstroms. The use of identifying features on the wafer surface helped reduce the variability of measurements. However, even with the help of surface features, it is questionable if trench depth measurements can be made at the same location before and after a period of polishing.

Assuming the absence of the damage layer and that one had the ability to make trench depth measurements at the same location, one additional phenomenon was observed which would make the use of this technique somewhat unreliable. After many

hours of polishing, the damage layer caused by reactive ion etching was removed from the trench bottoms. Figures 2 through 5 on the following page are photographs at 1000x magnification of Trench 4 on Wafer 5. A casual observation of the trenches reveals that the trench edges were not etched in a perfectly straight line. In fact, the end of the trench nearest the center of the wafer is seen at the top of these photographs and has a non-uniform, curved shape. The trenches extend across almost the entire width of these photographs. These photographs were taken during a study at 120 rpm using 5 lb/in<sup>2</sup> applied pressure. Figure 2 is a photograph taken after polishing with a 3 $\mu$ m diamond polish for 2 minutes to re-introduce scratches on the wafer surface. Figures 3, 4, and 5 are photographs taken after chemical mechanical polishing for 1 hour, 1.5 hours, and 2 hours respectively. A comparison of the photographs will reveal that polishing is occurring at the bottom of the trenches. After two hours of polishing, most of the scratches that were present prior to CMP have been removed. This polishing effect is occurring because the trenches are approximately 2 $\mu$ m deep while the pad polishing fibers can be as long as 50 $\mu$ m. The removal of material from the bottom of the trenches would introduce error into removal rates calculated from Dektak trench depth measurements.



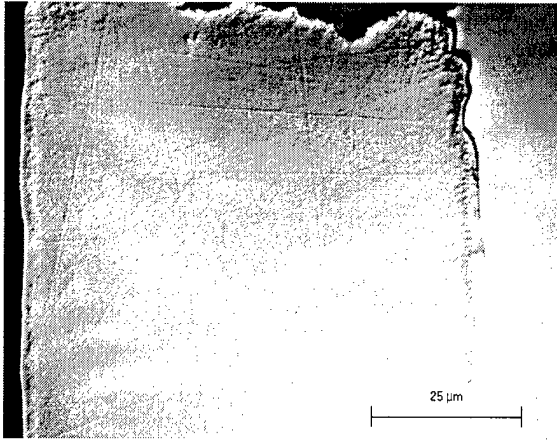

Figure 2: Wafer 5 – Trench 4 at 1000x magnification – pre-polish condition

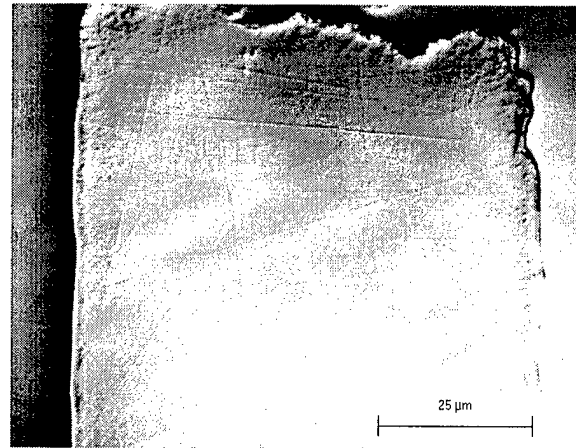

Figure 3: Wafer 5 – Trench 4 at 1000x magnification – post 1-hour polish condition

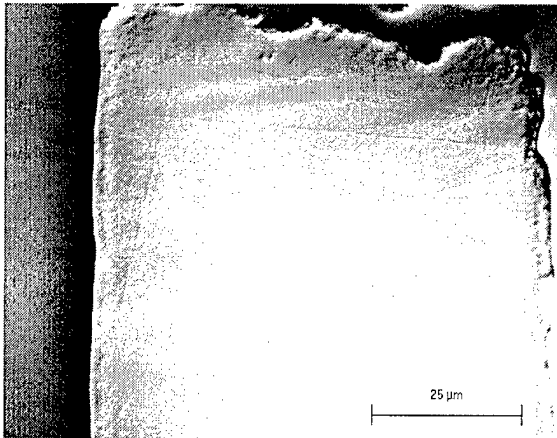

Figure 4: Wafer 5 – Trench 4 at 1000x magnification – post 1.5-hour polish condition

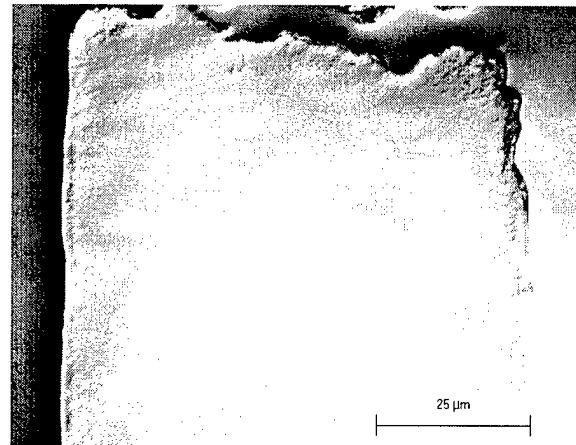

Figure 5: Wafer 5 – Trench 4 at 1000x magnification – post 2-hour polish condition

\*The darkened spots and blotches on each photograph were caused by small dust particles on the interior microscope lens system which could not be removed.

The final method of removal rate determination that was examined consisted of making mass measurements before and after each polish. Assuming a SiC density of  $3.21 \text{ g/cm}^3$  and a  $1 \frac{3}{8}$ " diameter wafer, one can make the simple calculation and discover that the removal of 100 angstroms of SiC corresponds to approximately 31 micro-grams. This calculation assumes that material removal is perfectly uniform across

the entire wafer surface. For this particular study, a Mettler AT20 scale was used which has a resolution of the nearest even micro-gram. Lengths of the major and minor flats were measured for each wafer using a machinist's microscope and digital length readout (Wafer flats are shown in Figure 6 on page 25). The area removed by forming the flats was subtracted from the area of a perfect circle with a diameter of 1 3/8 inches. The measured diameter of the wafer varied by  $\pm 0.003$  inches. Calculated wafer areas ranged from 1.4890 in<sup>2</sup> to 1.4896 in<sup>2</sup> for the wafers used in this study.

Wafer major flats (sometimes termed primary flats) and minor flats (secondary flats) are typically ground along the length of the wafer ingot prior to slicing individual wafers from the ingot. The major flat provides a means of positioning the wafer for processing by automated equipment. The minor flat(s) helps identify the orientation and conductivity type of the crystal (Sze, 1985:314).

Several assumptions were made in the application of this removal rate determination method. First, it was assumed that the polishing process proceeded uniformly over the entire surface of the wafer. This assumption is not completely correct since lubrication hydrodynamics presented by Levert and Tichy predict the total pressure will be greater at the wafer center than at the edges. Therefore, wafer edges will be polished at a different rate than the middle of the wafer. Since the purpose of this study is to obtain information on the effect several parameters have on the polishing process, it is not necessary to obtain an absolute value for removal rate at one particular point on the wafer surface. Rather, it is acceptable to make the above assumption and investigate the differences in calculated removal rate which occur with changing parameters.

Secondly, the assumption was made that the four trenches did not significantly affect the removal rate calculated by mass measurements. As previously mentioned, a damage layer existed at the bottom of the four trenches after performing a plasma etch. The following conservative assumptions were made in the calculation of material mass that could be removed from the trench bottoms:

- 1) Each trench is approximately 4 milli-meters long and 75 micro-meters wide
- 2) the damage layer material density is equal to the density of SiC
- 3) up to 2000 angstroms of damage layer material can be removed from the trench bottom in each one hour polishing period

Given these assumptions, the combined, maximum mass of material that can be removed from the bottom of the four trenches is less than 0.8 micro-grams. Thus, the assumption that damage layer material removal from the trench bottoms does not significantly affect the overall removal rate is an acceptable one since the minimum removal rate occurred at 60 rpm and high slurry pH values and resulted in a 30 micro-gram loss. Also, wafers 5 and 6 had been polished for at least 3 hours each prior to this mass removal data. The 2000 angstroms of damage layer removal from the trenches occurred only during the very first hour of polishing and decreased until the damage layer was completely removed.

While performing preliminary polishing studies, it was observed that small pieces of the wafer were chipped off during polishing at and around the edge cracks and defects. This occurred with more frequency when the wafer was polished at higher speeds. Of course, even a small piece of wafer removed by chipping can have a large impact on

removal rate calculations since in some cases only 100 angstroms of material was removed in an hour of polishing. Besides adequately securing the wafer to the polishing substrate, there was no way to prevent the wafer from chipping during the polishing process. However, before and after each polish, the wafer edges were examined at 100x and 500x magnification. Pictures of edge defects were taken prior to polishing and these pictures were compared to post-polish microscope images. It is believed that this procedure was adequate in spotting wafer defect chipping, but an absence of all edge cracks and defects would be the most desirable condition.

### **III. Experimental Procedures**

#### **Sample Description**

The samples used in this study consisted of five, 8° off-axis SiC wafers manufactured by Cree Research Incorporated. The wafers were 4H- SiC with physical dimensions of 1 3/8” in diameter and an average thickness of approximately 0.394 millimeters. Additionally, each wafer was grown with an advertised micro-pipe density of 50 micro-pipes per square centimeter. All five wafers were cut from the same boule and were consecutive wafers of the boule. The SiC wafers used for this study had an identification number of Z0273-02 through Z0273-06 and will be referred to as Wafer 2 through Wafer 6 in this report. The wafers were delivered to the Air Force under DARPA funded contract F33615-95-C-5426.

Prior to any other action, each wafer was thoroughly examined with an optical microscope. The optical microscope used for this study was a Zeiss Axiotron II with a Hitachi HV-C20 camera and supporting Zeiss Image 3.0 software. The microscope was capable of up to 1000x magnification and had the capacity of Nomarski differential contrast. The camera and software allowed the creation of the digital photographs which will be presented in this report. Unfortunately, dust particles accumulated at an undetermined location on the interior of the microscope lens system. Although several attempts to find and remove the particles were made, the attempts were unsuccessful. The particles appeared as darkened spots and blotches on the digital photographs. Although they could not be eliminated, the effects of the particles were mitigated by varying the light intensity setting, aperture size and light polarization.

During the initial examination of the samples, two main observations were made:

1. defects existed predominantly but not exclusively around the edges of the wafers
2. the as received wafers contained residual scratches left from the polishing process executed by Cree.

Although their wafer polishing process is proprietary, it is believed that Cree uses a polish with a diamond grit of approximately 1 micro-meter in diameter as the final step in their polishing process. This determination was made after comparing the as received wafer scratches to scratches made with a 1 micro-meter diamond polish.

### **Wafer Defects**

After thoroughly observing the wafer surface at various magnifications, defects were discovered that existed primarily, but not exclusively, close to the edge of the wafer. These defects were visible at 12.5x magnification and appeared to be grouped together at three to four distinct locations on each wafer surface. Besides being in the same location on each wafer, the shapes of the defect groups appeared to be extremely similar when compared to defect groups on adjacent wafers. It was theorized that the defects were a result of a less than desirable crystal growth environment and extended through the entire thickness of the wafers. It appears that the defects do indeed extend through the thickness of the wafers since they are visibly unaffected after many hours of polishing. Figure 6 illustrates the location of the wafer defects and the four etched trenches in relation to the wafer major and minor flats.

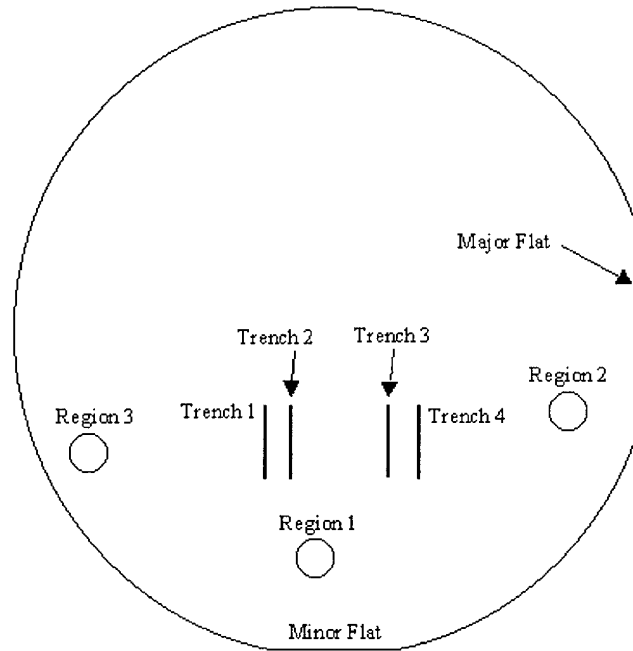

Figure 6: Scaled sketch of 1 3/8" Cree samples with defect region and trench locations

Although the presence of defects in a semiconductor are detrimental in almost all cases, they proved to be an important asset during the course of this particular research. With the assumption that the defects extended through the entire thickness of the wafer, it was only reasonable to believe that the defects could be used as landmarks to help evaluate the effectiveness of each polishing period. The existence of the wafer defects made it possible to take digital photographs of the same location on the wafer before and after each polishing period. Thus, instead of presenting photographs of scratches 'somewhere' on the wafer surface and showing a smooth wafer surface 'somewhere else' after polishing, this report will present photographs of the exact same location before and after each polishing period. Figures 7 through 10 show the general shape of the defect groups near Region 1 at 12.5x magnification and Regions 1, 2, and 3 at 100x magnification. Although not shown, Regions 2 and 3 shown in Figures 9 and 10 are part

of a larger cluster of defects. Also, although Figures 7 through 10 do show the general location of the wafer defects, it is not always clear which defects at 100x magnification correspond to defects viewed in 1000x magnification photographs.

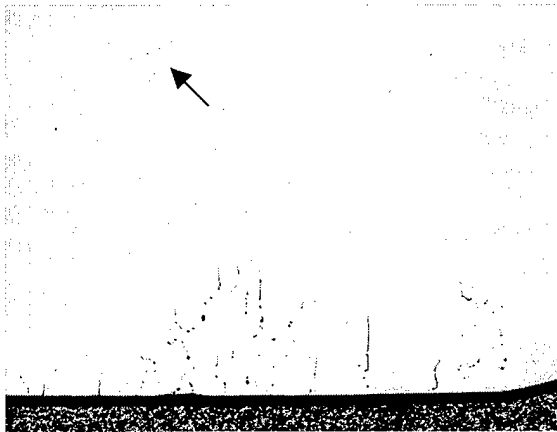

Figure 7: Wafer 6 – Minor Flat Defects at 12.5x magnification

(Arrow indicates location of Region 1)

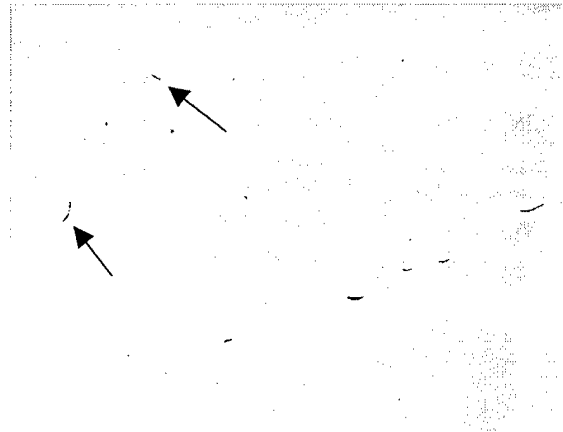

Figure 8: Wafer 6 – Region 1 at 100x magnification

(Arrows indicate location of 1000x defect photographs for Wafers 5 and 6)



Figure 9: Wafer 6 – Region 2 at 100x magnification

(Arrows indicate location of 1000x defect photographs for Wafers 5 and 6)

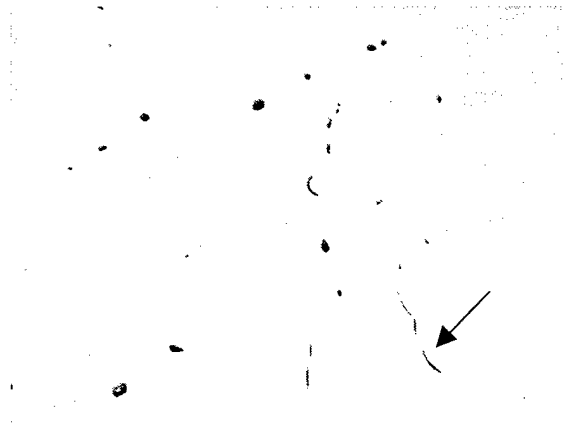

Figure 10: Wafer 6 – Region 3 at 100x magnification

(Arrow indicates location of 1000x defect photographs for Wafer 6)



### Wafer Residual Scratches

As expected, residual scratches were observed on the wafer surface at 500 and 1000x magnification. Figures 11 through 14 are photographs at several locations on as received wafers.

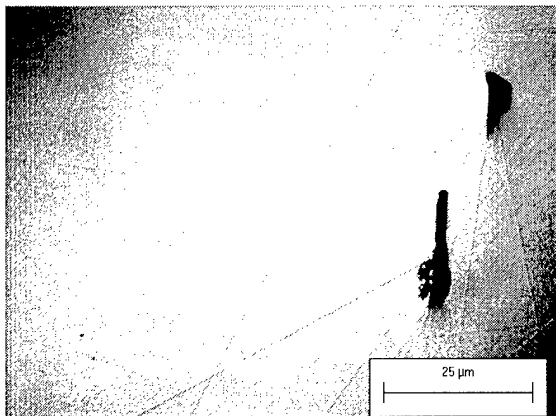

Figure 11: Wafer 2 – Region 2 at 1000x magnification – as received condition

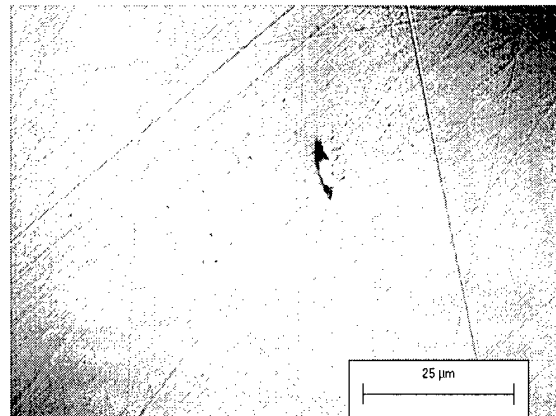

Figure 12: Wafer 4 – Region 1 at 1000x magnification – as received condition

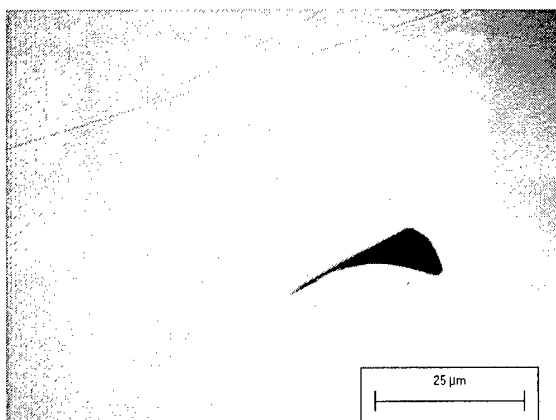

Figure 13: Wafer 5 – Region 3 at 1000x magnification – as received condition

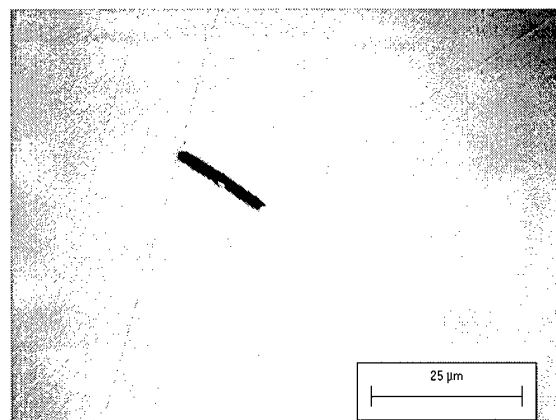

Figure 14: Wafer 6 – Region 1 at 1000x magnification – as received condition

Figure 11 through 14 photographs were taken prior to etching the four trenches on the wafer surfaces. After completing the reactive ion etch process, the scratches were re-examined. Pre and post etch photographs of the scratches were identical. Therefore, the conclusion was made that the etching process did not change the surface morphology of the wafers except at the etch location. Figures 15 through 18 are photographs at the ends of several trenches after they were etched but prior to any polishing. The trenches appear as dark regions in the photographs. All trench photographs were taken at the trench ends that are closest to the center of the wafer.

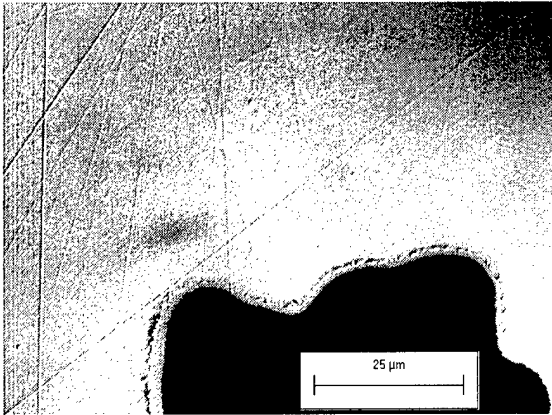

Figure 15: Wafer 3 – Trench 4 at 1000x magnification – post-etch, pre-polish

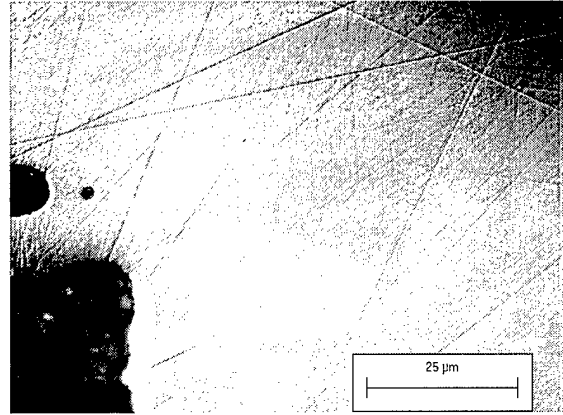

Figure 16: Wafer 4 – Trench 2 at 1000x magnification – post-etch, pre-polish

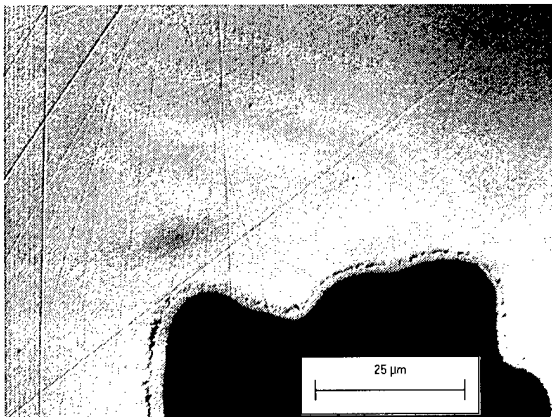

Figure 17: Wafer 5 – Trench 2 at 1000x magnification – post-etch, pre-polish

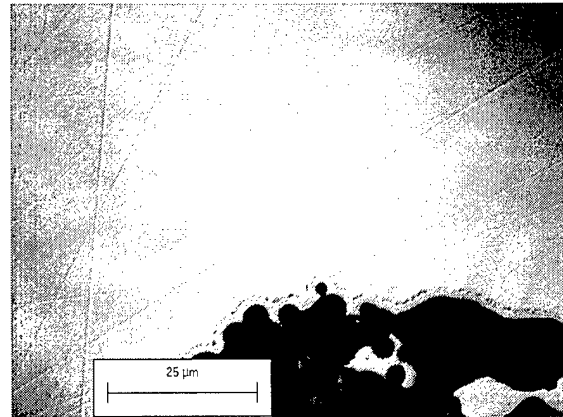

Figure 18: Wafer 6 – Trench 2 at 1000x magnification – post-etch, pre-polish

In addition to optical microscopy, the wafers were examined using Atomic Force Microscopy (AFM). AFM photographs and measurements were made using a Dimension 3000 large sample microscope system with a Digital Instruments NanoScope IIIa microscope controller. Photographs and measurements were obtained by operating the microscope in tapping mode. Prior to any polishing, AFM measurements were taken on the surfaces of Wafers 2 through 6. Figure 19 illustrates a typical AFM amplitude image of the surfaces of Wafers 2 through 6. Figure 19 illustrates a typical AFM amplitude image of Wafer 6 in the as received condition.

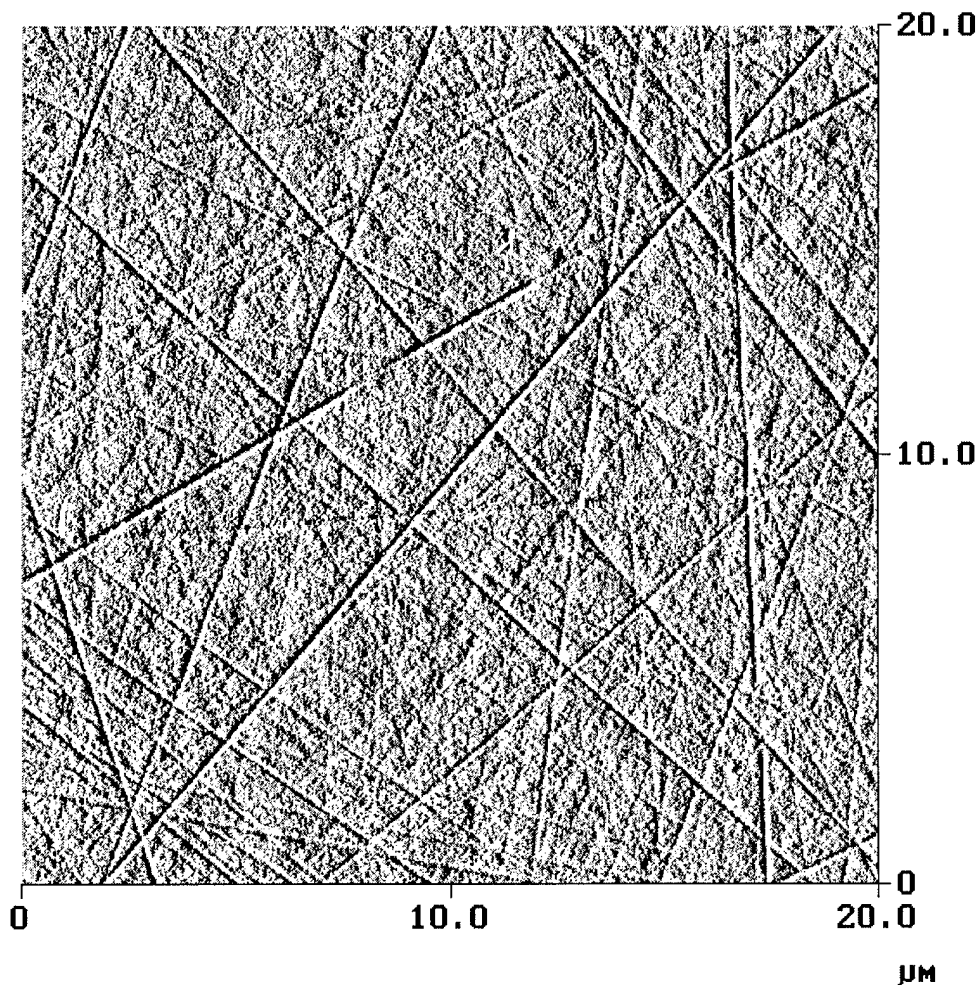

Figure 19: Typical AFM Amplitude image of the wafer surface as received from Cree Research Incorporated (Image obtained from Wafer 6)

The scratches observed in Figure 19 were typical for Wafers 2 through 6 and illustrate the presence of scratches to a greater degree of resolution than the optical microscopy photographs at 1000x magnification. AFM height images were used to measure the depth and width of several scratches on as-received wafers. The scratch dimensions ranged from 0.9nm deep and 430nm wide for 'small' scratches to 4.6nm deep and 390nm wide for 'deep' scratches.

### **Sample Mounting**

Proper preparation techniques are critical for effective polishing of the semiconductor wafer. It is imperative that the wafer be mounted as level as possible to promote equal polishing over the entire surface of the wafer. Elevated temperature and slurry pH polishing pose special challenges that can be overcome with simple, common sense practices.

First, it is necessary to use an adhesive that is capable of securing the wafer to the mount during a polishing session. The adhesive must be capable of withstanding the polishing temperatures, high or low slurry pH levels, and the shear stresses that will be imparted to the wafer by the polishing pad. In addition, the adhesive should be relatively easy to completely remove from both the mount and the wafer. Finally, the adhesive should not induce significant shear stresses on the wafer as a result of adhesive curing. Adhesives such as Loctite 332 Structural Adhesive should only be used with extreme care since they can induce shear stresses that cause the wafer to shatter after completely curing.

For this particular study, Gugolz #91 polishing pitch was used to secure the wafer to the metal mount. This pitch had sufficient strength at 70°C to allow a full hour of polishing with no movement of the wafer on the mount. One common trait of various pitches is the tendency of the pitch to soften and yield at temperatures significantly lower than the advertised melting temperature. This leads to movement of the wafer during the polishing operation with the possibility of breaking the wafer when it becomes fully detached from the wafer mount.

In addition to temperature, this particular pitch was sensitive to higher pH slurries. At slurry pH levels as low as 11, the pitch dissolved into the slurry solution producing a white foam on the polishing pad. In combination with higher temperatures, this chemical reaction had the potential of disastrous results. The slurry attacked any pitch surrounding the edges of the wafer and even underneath the wafer edges if the wafer was mounted on a layer of pitch that was too thick. To avoid separation of the wafer from the wafer mount, wafer attachment procedures were developed. Appendix B presents the procedures used for securing the wafer to the metal mount in preparation for chemical mechanical polishing. Upon completion of these steps, the wafer was adequately secured to the mount to allow polishing for at least 60 minutes at elevated temperatures and slurry pH levels.

### **Sample Polishing**

Following the procedures in Appendix B, the wafer and mount were ready for integration with the polishing device. A Strasbaugh Precision Polishmaster (Model R6UR-DC-4) with a random motion polishing armature was used for this study. Rodel

10” regular politex polishing pads were attached to the 10” polishing platen. These pads consisted of polyurethane/polyester fibers. Logitech SF1 colloidal silica polishing solution was used as the polishing agent. Figure 20 illustrates the integration of the wafer mount and the polishing station.

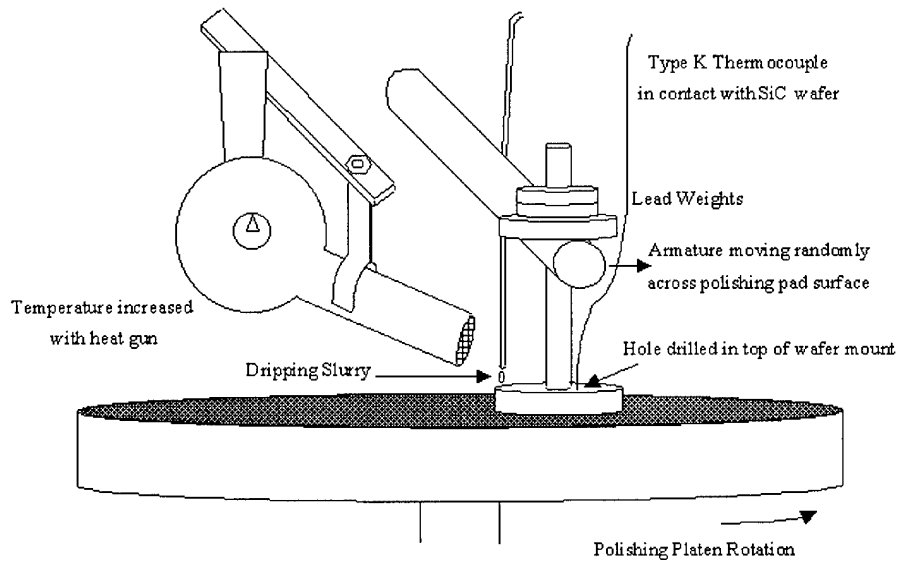

Figure 20: Typical set-up for SiC CMP

Several points should be explained regarding Figure 20. The heat gun shown in the figure was used only when studying the effects of increased temperature on material removal rate. It was mounted to an aluminum T-section that was not in direct contact with the armature. Thus, placement of the heat gun in the clamp did not place additional weight or a moment arm on the polishing armature. Although not attached directly to the armature, the heat gun T-section was fastened to a cam which caused the armature to move back and forth across the pad. Thus, in the case of higher temperature experiments, the heat gun remained at a constant distance away from the wafer mount unless it was

physically moved in the clamp during the experiment in order to increase/decrease the wafer temperature.

Note that a small hole was drilled through the wafer mount. This hole was just large enough to allow the placement of an insulated thermocouple wire through the hole and in direct contact with the back of the SiC wafer. In addition, two layers of electrical tape were placed over the thermocouple wire and the mount hole. The purpose of the tape was two-fold: secure the thermocouple wire and prevent the heated air of the heat gun from entering the hole and introducing additional error into the temperature reading.

Finally, although it is not shown, a thin tin plate was wrapped around the metal mount to help prevent the hot air of the heat gun from drying the pad and to allow the wafer to reach higher temperatures. The tin plate extended approximately 2 inches above the wafer mount surface and was attached to the mount with a band clamp. A semi-circular section was cut in one side of the tin cylinder to allow the air from the heat gun to directly impact the mount surface.

The armature settings were approximately 0.75 inches for the off center setting and 3.5 inches for the traveling head setting. These settings caused the center of the armature to travel randomly between 3 and 4 inches across the polishing platen surface at a rate of about 12 complete cycles per minute. Figure 21 illustrates a top view of the random motion of the armature during polishing. These particular armature settings resulted in smooth polishing without armature vibrations, which occurred if the armature traveled too close to 'Edge A' in Figure 21.

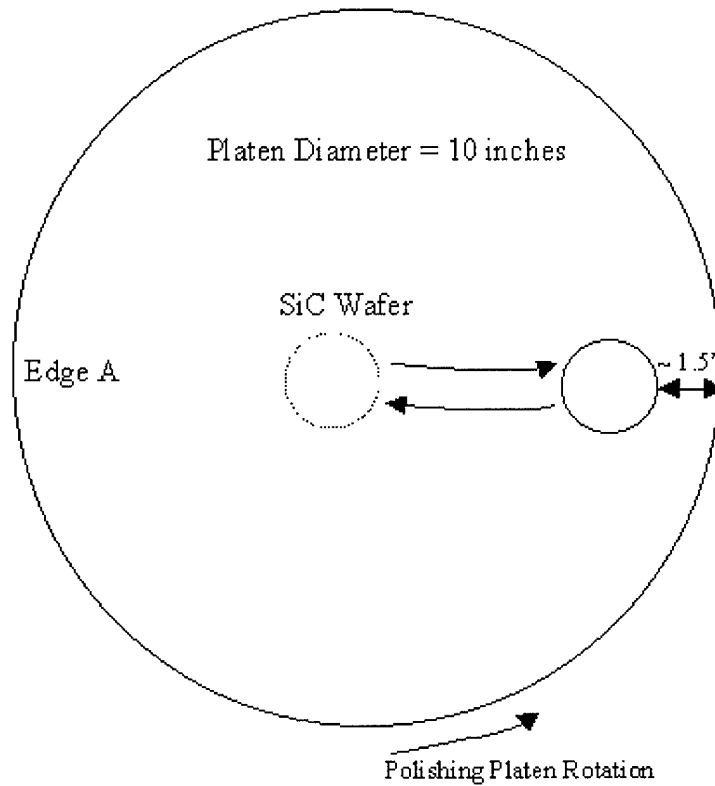

Figure 21: Wafer motion across pad surface

Following integration of the wafer and mount to the polishing station, the wafer was ready for polishing. Typically, the wafer was polished for three or four 60 minute periods. For high rotational speed studies the wafers were polished for three to four 30 minute intervals. After each polishing interval, the wafer and mount were removed from the polishing station and thoroughly rinsed in distilled water and dried with a soft tissue. The polishing pad was also rinsed with running water to remove remaining pad slurry and any other particles.

After rinsing with water and prior to removal of the wafer from the mount, the wafer edges were examined at 100x and 500x magnification in an attempt to identify the occurrence of chipping during the polishing period. Photographs taken prior to the



polishing period were compared to images of the wafer edges after polishing. In the event of noticeable damage, the removal rate was identified as a value that contained probable error. Although edge damage was observed for several preliminary studies, no edge damage was noticed for temperature, pH level, pressure, or rotational speed studies summarized in the following chapter.

After carefully examining wafer edges, the wafer was removed from the wafer mount and prepared for mass measurements. The wafer was removed by placing the mount and wafer on a hotplate and increasing the temperature of the hotplate until the polishing pitch was liquified. The wafer was then carefully pushed to the edge of the mount and removed for cleaning.

Because material removal rates were determined by mass measurements, it was critical that all foreign matter be removed from the wafer after each polishing period. A cleaning procedure was developed that proved to be adequate in preparing the wafers for mass measurements. This procedure can be found in Appendix C. In short, the wafer was wiped with trichloroethylene and a cotton ball until the surface was void of visible pitch residue. The wafer was then placed in two 10 minute ultrasonic baths of trichloroethylene followed by rinsings in acetone and alcohol. This procedure was developed after it was discovered that polishing pitch became embedded in wafer defects. The ultrasonic baths were successful in removing pitch and other contaminants from the wafer surface and defect sites.

After developing this cleaning procedure, it's effectiveness was tested. After polishing Wafer 4 for a 60 minute period, the wafer was removed, examined and cleaned

in accordance with the procedure in Appendix C. Two mass measurements were taken using the Mettler scale. Following these initial measurements, the wafer was placed in a third, fourth, and fifth 10 minute ultrasonic bath with mass measurements taken after each additional cleaning. Finally, the wafer was placed in a vacuum of approximately 1 torr in a final effort to remove any contaminants from the wafer. Table 1 summarizes the mass measurements taken after each cleaning.

Table 1: Wafer Cleaning Procedure Effectiveness Analysis

<b>Action</b>	<b>1<sup>st</sup> Mass Measurement (grams)</b>	<b>2<sup>nd</sup> Mass Measurement (grams)</b>
2 – 10 minute ultrasonic baths in trichloroethylene	1.231216	1.231214
3 <sup>rd</sup> – 10 minute ultrasonic baths in trichloroethylene	1.231214	1.231214
4 <sup>th</sup> – 10 minute ultrasonic baths in trichloroethylene	1.231214	1.231214
5 <sup>th</sup> – 10 minute ultrasonic baths in trichloroethylene	1.231214	1.231214
Exposure to 1 torr vacuum	1.231216	1.231216

Two conclusions can be made after an examination of the data in Table 1. First, the procedure described in Appendix C seems adequate in cleaning the wafer for mass measurements. No significant mass differences were observed after additional cleaning of the wafer and exposure to a low pressure environment. Second, the mass measurements obtained using the Mettler scale are very repeatable. After making 12 separate mass measurements, a difference of only 2 micro-grams between measurements was experienced. Although the measurements were very repeatable, two mass readings

were obtained after each polishing period and an average of the two values was used in removal rate calculations.

Following mass measurements, photographs of the wafer were taken at Regions 1, 2, and 3 and at the ends of Trenches 1, 2, 3, and 4. The trenches were photographed at the ends closest to the center of the wafer. These photographs were used to help collaborate the removal rate data obtained from mass measurements and will be presented with removal rate data in the following chapter. After obtaining these seven photographs, the wafer was ready for another period of polishing.

Many different combinations of polishing parameters were examined during the course of this research. Initially, studies using Logitech slurry with a pH of 9.9 at 3 lb/in<sup>2</sup> and 180 rpm at various temperatures were performed. The results of these studies are summarized in the first section of the following chapter. Using the knowledge gained from these preliminary results, additional studies were defined and evaluated. In total, an additional twelve experiments consisting of different combinations of parameters were performed following the preliminary study. Each combination of parameters was studied for three or four periods of 30 or 60 minute polishing intervals. Table 2 summarizes the polishing parameters used in these twelve experiments.

Table 2: Experiment Polishing Parameters Summary

Test #	Wafer #	Polishing Interval (Minutes)	TC Temperature (°C)	Slurry pH Level	Applied Pressure (lb/in <sup>2</sup> )	Pad Rotational Speed (rpm)
1	5	60	23	9.9	5	60
2	5	60	65	9.9	5	60
3	5	60	23	11	5	60
4	6	60	23	11	5	90
5	6	60	23	12	5	90
6	6	60	23	9.9	7	90
7	6	60	23	9.9	9	90
8	6	60	23	9.9	11	90
9	5	60	23	9.9	5	90
10	5	30	23	9.9	5	120
11	5	30	23	9.9	5	150
12	5	30	23	9.9	5	180

Temperature Study: Tests 1 and 2

Slurry pH Level Study: Tests 1, 3, 4, and 5

Applied Pressure Study: Tests 6, 7, 8, and 9

Pad Rotational Speed Study: Tests 1, 9, 10, 11, and 12

## IV. Experimental Results

This chapter will be divided into 6 sections. Section 1 briefly presents results obtained from preliminary polishing experiments. Section 2 summarizes the temperature study results while section 3 discusses pH study findings. Sections 4 and 5 discuss the results of applied pressure and pad rotational speed studies, respectively. Finally, section 6 presents AFM results obtained after polishing for 3 hours at the optimum polishing parameters.

### Preliminary Study

Preliminary studies were conducted at 180 rpm using as received Logitech polishing slurry at 3 lb/in<sup>2</sup> and at several different temperatures. Some of the results are shown in Table 3.

Table 3: Preliminary Study Results

Wafer #	Wafer Temperature ( C )	Pad Life ( Hours )	Wafer Damage?	Removal Rate ( Å/Hour)
6	25	New	No	214
6	25	1	No	1131
6	25	2	No	408
4	25	New	No	175
4	25	1	No	198
4	25	2	No	875
5	65	New	No	645
5	65	1	Yes*	985
5	65	2	No	392
6	70	New	No	765
6	70	1	No	334
6	70	2	Yes*	885

\*These are two of several data points where damage on the wafer edge was noticed at 100x magnification.

A review of the data reveals a disturbing conclusion; the removal rate data is extremely random. For example, polishing at 25°C yielded removal rates of 214, 1131, and 408Å/hour for a pad that was new, 1 hour old, and 2 hours old respectively. To make matters worse, the photographs supported the removal rate data. During hours when the removal rate was low, little difference between pre- and post-polish photographs was noticed. During periods of large calculated removal rate values, wafer scratches were almost entirely removed.

Following additional research, it was concluded that most of the randomness was caused by the high pad rotational speed. At 180 rpm, most of the slurry was being flung from the edge of the pad and down the drain. During a period of high removal rate, the slurry was probably taking a fortunate ‘bounce’ towards the wafer surface. In addition, it was thought that the pressure of 3 lb/in<sup>2</sup> could have been too low.

In order to stabilize the calculated material removal rates for the temperature, slurry pH and pressure studies, the following two changes were made to the polishing parameters:

1. the polishing speed was reduced to 60 rpm or 90 rpm
2. the applied pressure was increased to 5 lb/in<sup>2</sup>

As hoped, these changes brought immediate stabilization to the calculated removal rates. Subsequent sections will discuss the results obtained after making these changes.

### **Temperature Study**

Two temperatures were studied after stabilizing the material removal rate. Studies at 23°C and 65°C were conducted with as received polishing slurry. The applied pressure was 5 lb/in<sup>2</sup> and pad rotational speed was 60 rpm. With the moderate pressure

and slow speed, a thin film of slurry was maintained on the entire wafer surface with a slurry feed rate of approximately 455 ml/hour for the 23°C study and 575 ml/hour for the 65°C study. Wafer 5 was polished for four – 60 minute periods at 23°C and at 65°C.

Figure 22 presents the calculated removal rates at both temperatures.

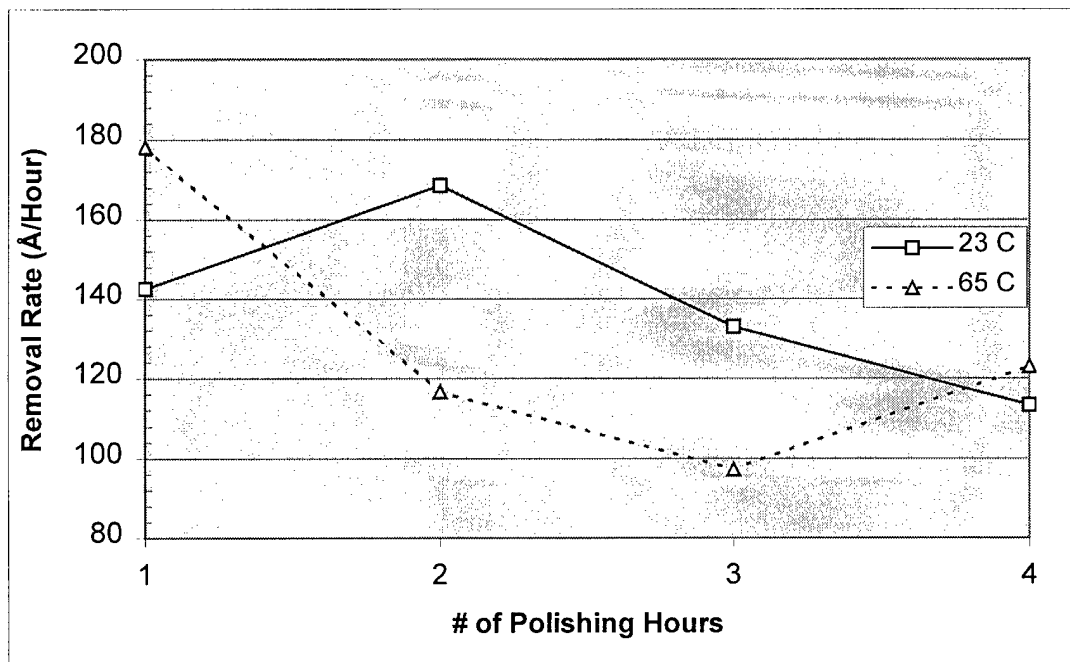

Figure 22: Temperature study at 60 rpm and 5 lb/in<sup>2</sup>

The average removal rate at 23°C over the 4 hour period was approximately 139Å/hour while the average at 65°C was approximately 129Å/hour. Although slight variations existed in material removal rate calculations during the four – 60 minute periods, the general trend indicates that increased temperature does not have a significant effect on material removal rate. This finding corresponds with that of Li (Li et al., 1995:601). The following photographs illustrate the physical changes that occurred on the wafer surface over three of the four 60 minute polishing periods at both temperatures. Figures 23 through 26 are pre-polish, post 1-hour, post 2-hour, and post 3-hour photographs of wafer 5 during the 23°C study. Figures 27 through 30 are pre-polish, post

1-hour, post 2-hour, and post 3-hour photographs of wafer 5 during the 65°C study.

Additional photographs of the 23°C and 65°C study can be found in Appendix D and E respectively.

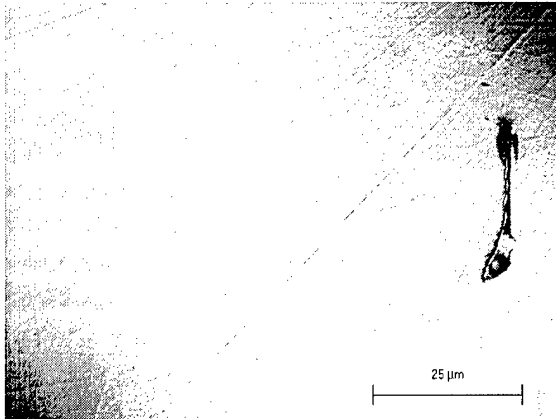

Figure 23: Wafer 5 – Region 1 at 1000x magnification – pre-polish condition

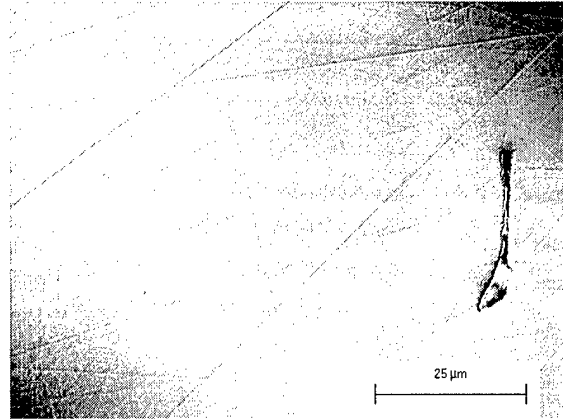

Figure 24: Wafer 5 – Region 1 at 1000x magnification – post 1-hour polish, TC temperature = 23°C condition

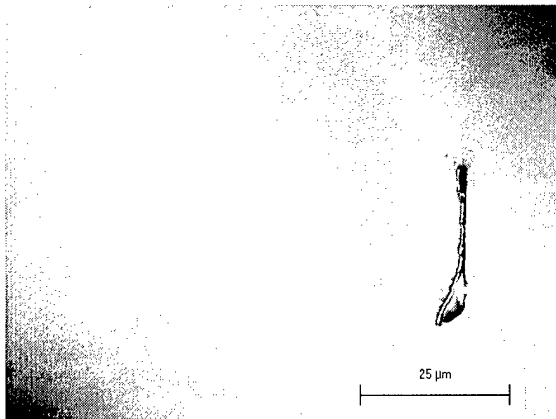

Figure 25: Wafer 5 – Region 1 at 1000x magnification – post 2-hour polish, TC temperature = 23°C condition

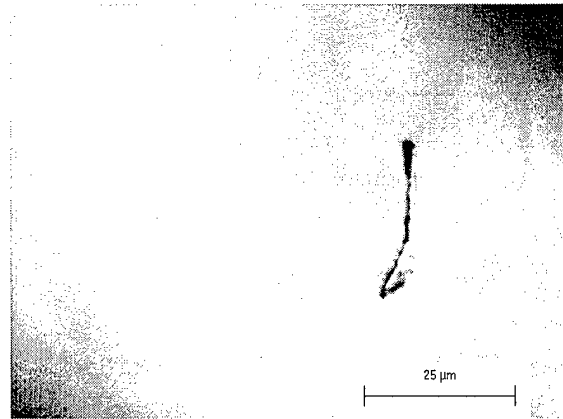

Figure 26: Wafer 5 – Region 1 at 1000x magnification – post 3-hour polish, TC temperature = 23°C condition

The total calculated material removed during the four hours of polishing at 23°C was 557 angstroms.



Notice that the first hour of polishing seemed to have little effect on the wafer surface scratches. This observation was common for photographs of each region during the first hour. While the first hour of polishing did not appear to remove deep scratches, it did smooth the roughened surface of the wafer.

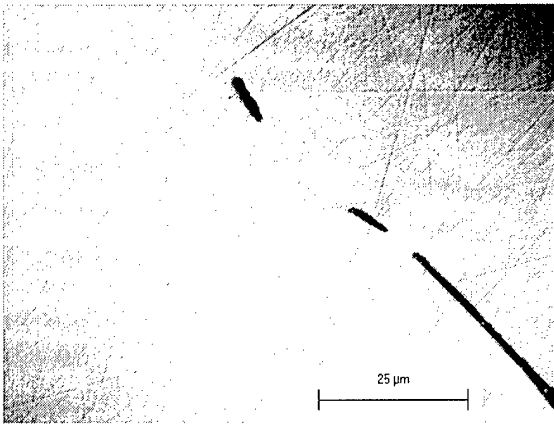

Figure 27: Wafer 5 – Region 2 at 1000x magnification – pre-polish condition

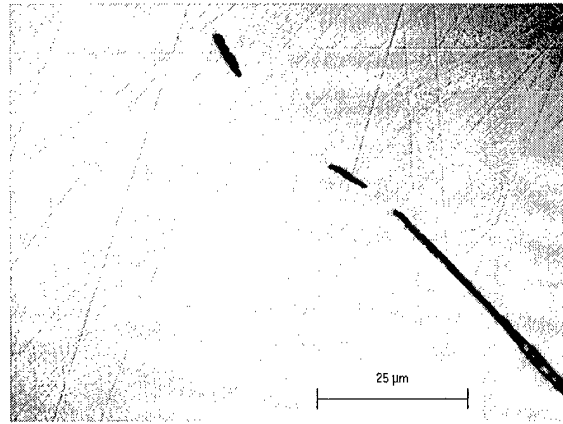

Figure 28: Wafer 5 – Region 2 at 1000x magnification – post 1-hour polish, TC temperature = 65°C condition

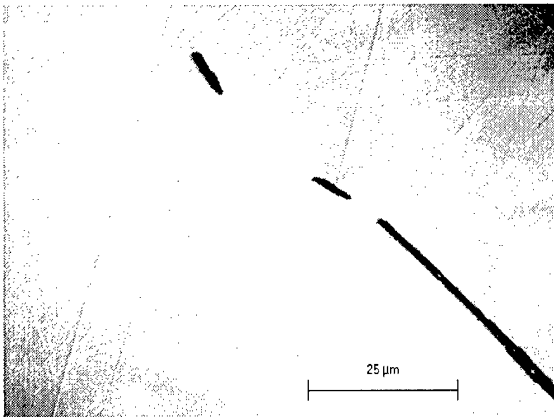

Figure 29: Wafer 5 – Region 2 at 1000x magnification – post 2-hour polish, TC temperature = 65°C condition

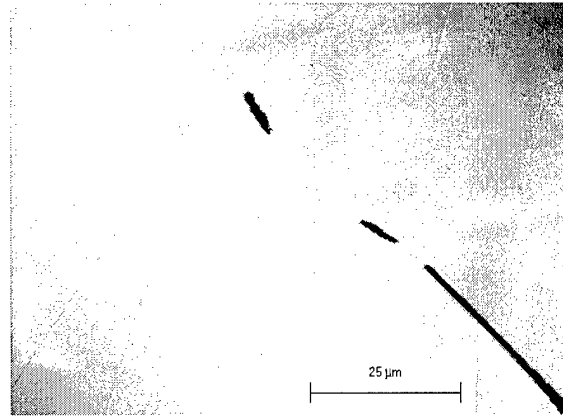

Figure 30: Wafer 5 – Region 2 at 1000x magnification – post 3-hour polish, TC temperature = 65°C condition

The total calculated material removed during the four hours of polishing at 65°C was 515 angstroms.

After examining the calculated removal rate data and the photographs, it becomes apparent that increased temperature did not significantly increase removal rate. This data does not support the idea that removal rates are increased by accelerating the reaction between the polishing slurry and wafer surface atoms as suggested by Zhou (Zhou et al., 1997:L161). Rather, this data supports the observation made by Li. The polishing pads used in this study are made with polyurethane/polyester composite fibers which exhibit very little change in dynamic shear modulus with increasing temperature. The results of temperature dependence as studied by Li, are confirmed with the data from this study.

### **Slurry pH Study**

Three different slurry pH levels were examined. After making an initial study of pH 11 slurry at 60 rpm, additional studies of pH 9.9, 11 and 12 were made at 90 rpm. While polishing at 60 rpm, approximately 455ml of slurry was used in a one hour period. The pH of the slurry was modified by adding various quantities of 1.25M NaOH solution to Logitech polishing slurry. To achieve a slurry pH of 11, approximately 24ml of 1.25M NaOH solution was added to 800ml Logitech polish. Figure 31 illustrates the material removal rate dependence on slurry pH with an applied pressure of 5 lb/in<sup>2</sup> and a rotational speed of 60 rpm.

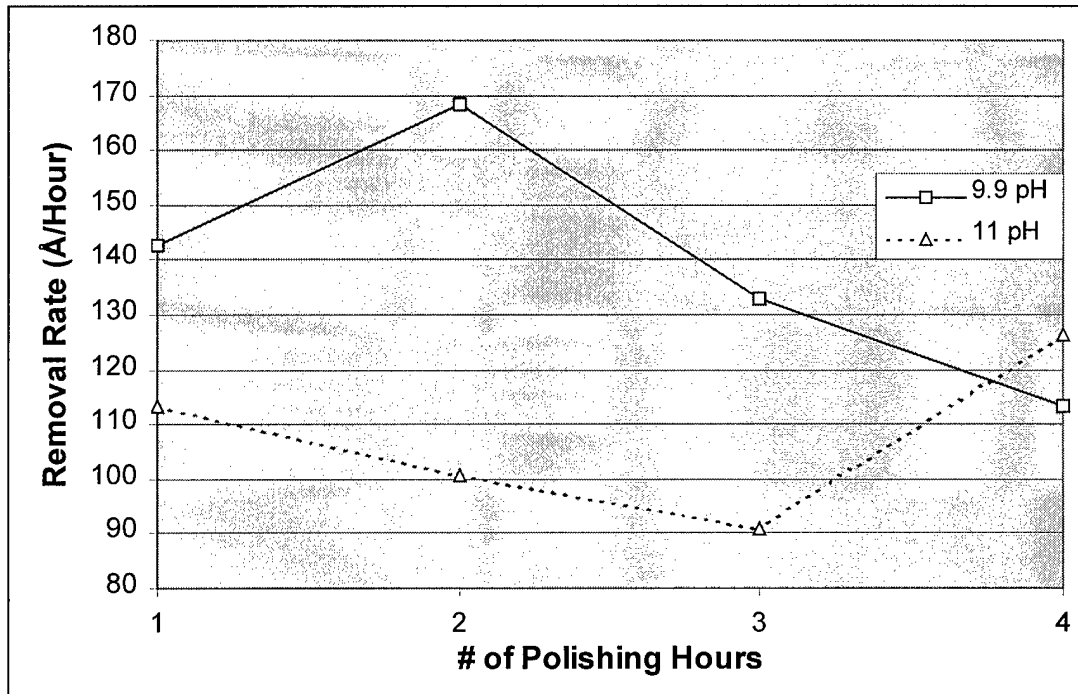

Figure 31: Slurry pH study at 60 rpm and 5 lb/in<sup>2</sup>

The average removal rate over the 4 hour period using Logitech polishing slurry was 139Å/hour while the average rate using an increased slurry pH of 11 was 108Å/hour. Thus, preliminary data suggested a decrease in removal rate with increasing slurry pH. Figures 23 through 26 are photographs of Wafer 5 at using Logitech slurry. Figures 32 through 35 are pre-polish, post 1-hour, post 2-hour, and post 3-hour photographs of wafer 5 using a slurry with a pH level of approximately 11. Additional photographs of the wafer 5 surface during the pH 11 slurry study can be found in Appendix F.

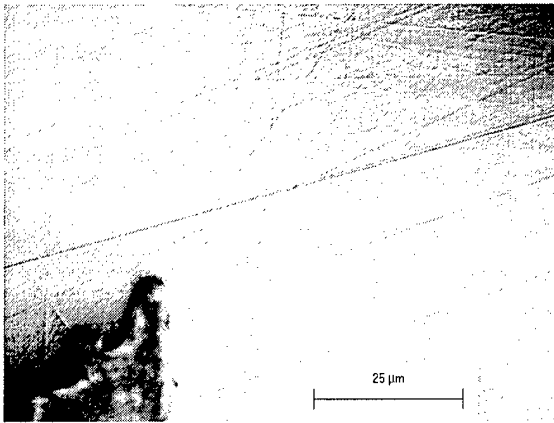

Figure 32: Wafer 5 – Trench 3 at 1000x magnification – pre-polish condition

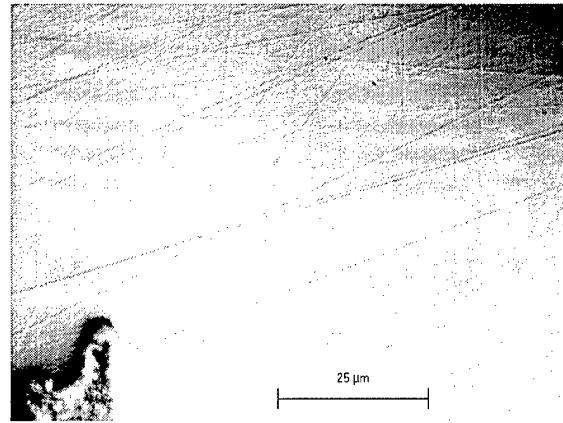

Figure 33: Wafer 5 – Trench 3 at 1000x magnification – post 1-hour polish, slurry pH = 11, rpm = 60 condition

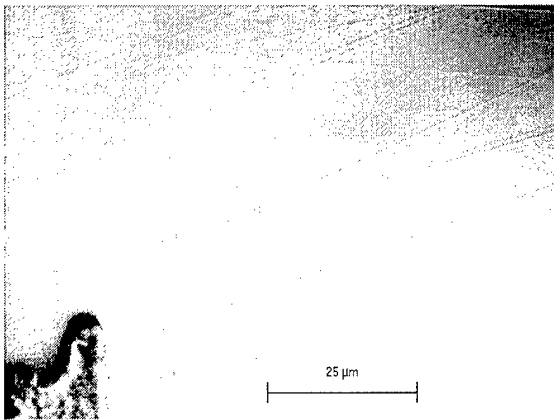

Figure 34: Wafer 5 – Trench 3 at 1000x magnification – post 2-hour polish, slurry pH = 11, rpm = 60 condition

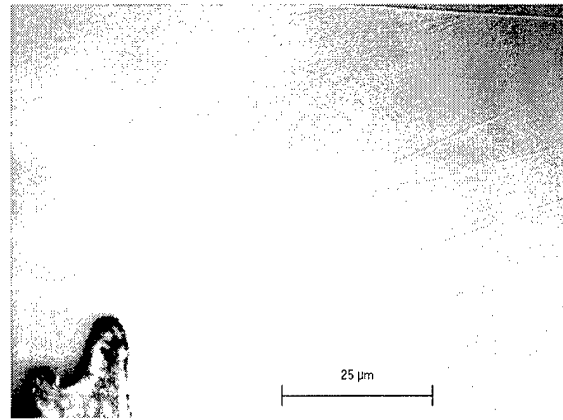

Figure 35: Wafer 5 – Trench 3 at 1000x magnification – post 3-hour polish, slurry pH = 11, rpm = 60 condition

The total calculated material removed during the four hours of polishing at 60 rpm with 11 pH slurry was 431 angstroms. Following this initial pH study, additional experiments were performed on Wafer 6 with slurry pH's of 9.9, 11, and 12, an applied pressure of 5 lb/in<sup>2</sup> and a rotational speed of 90 rpm. The increased polishing speed was used in hopes of exposing a larger removal rate difference between 9.9 and higher pH

slurries. The higher pH level of 12 was obtained by adding approximately 75ml of 1.25M NaOH solution to 800ml of Logitech slurry. At the higher rotational speed, between 700 and 750ml of polishing solution was used each hour. Figure 36 is a plot of material removal rates for polishing parameters of 23°C, 5 lb/in<sup>2</sup>, and 90rpm for slurry pH values of 9.9, 11, and 12.

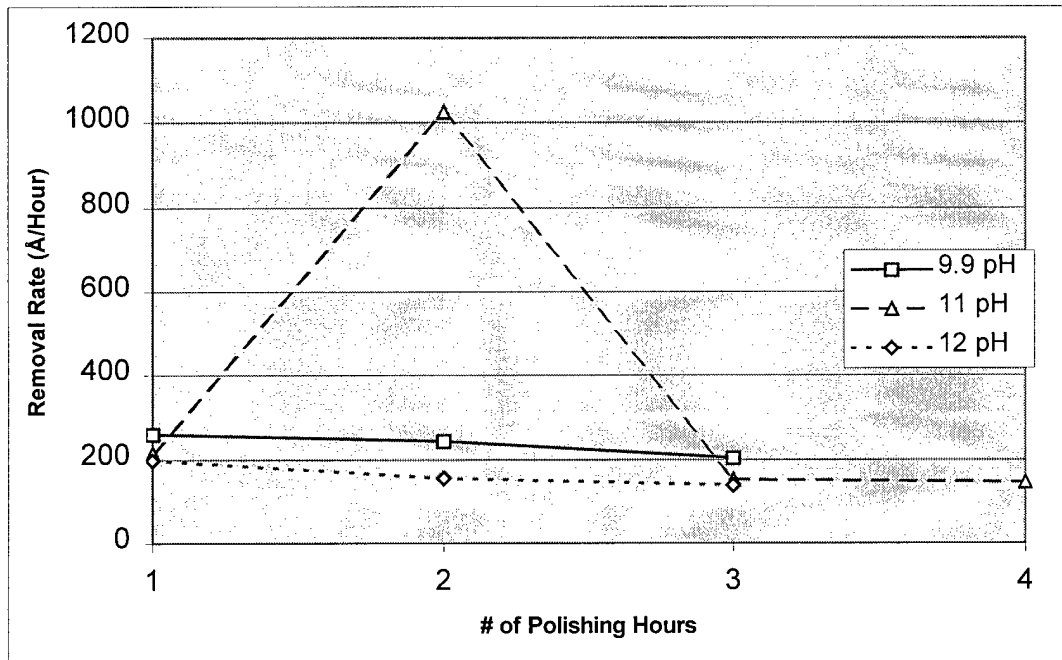

Figure 36: Slurry pH study at 90 rpm and 5 lb/in<sup>2</sup>

Except for the removal rate measured during the second hour of polishing with a slurry of pH 11, the removal rates for all three pH levels are quite stable and decrease slightly as the pad life increases. Both the preliminary pH study at 60rpm and the second study at 90rpm indicate that material removal rate actually decreases with increasing slurry pH levels. It appears the presence of many hydroxide molecules does not significantly raise the removal rate by increasing the reaction rate between the slurry and surface atoms.

Figures 37 through 40, 41 through 44, and 45 through 48 are photographs of Wafer 6 using a slurry with pH levels of 9.9, 11, and 12 respectively. Additional photographs of the wafer using polishing slurries with pH levels of 9.9, 11, and 12 at 90 rpm can be found in Appendix G, H, and I respectively.

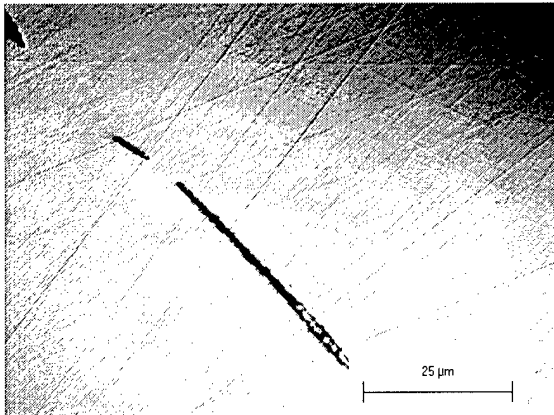

Figure 37: Wafer 5 – Region 2 at 1000x magnification – pre-polish condition

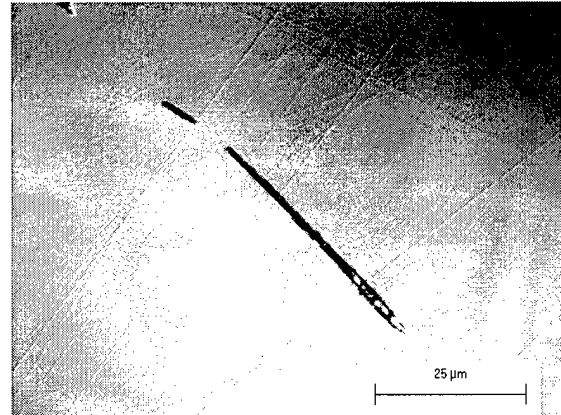

Figure 38: Wafer 5 – Region 2 at 1000x magnification – post 1-hour polish, slurry pH = 9.9, rpm = 90 condition

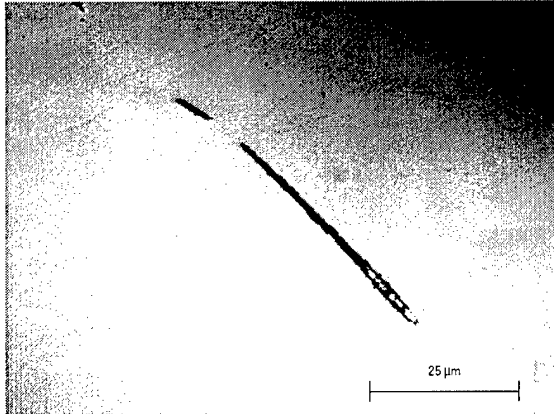

Figure 39: Wafer 5 – Region 2 at 1000x magnification – post 2-hour polish, slurry pH = 9.9, rpm = 90 condition

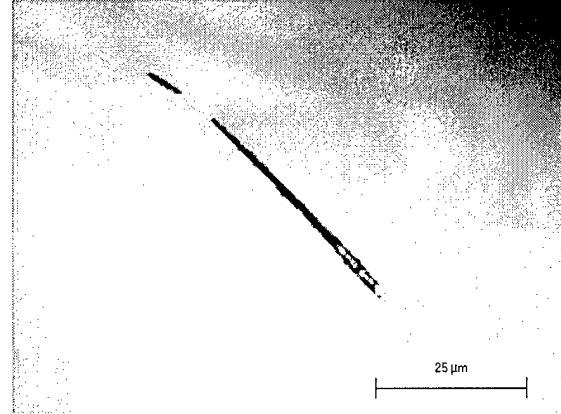

Figure 40: Wafer 5 – Region 2 at 1000x magnification – post 3-hour polish, slurry pH = 9.9, rpm = 90 condition

The total calculated material removed during the three hours of polishing at 90 rpm with a 9.9 pH slurry was 707 angstroms.

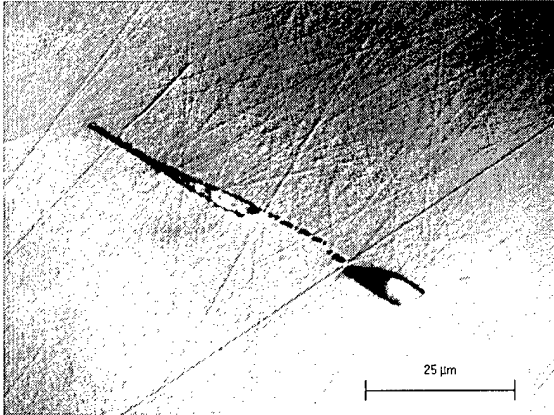

Figure 41: Wafer 6 – Region 2 at 1000x magnification – pre-polish condition

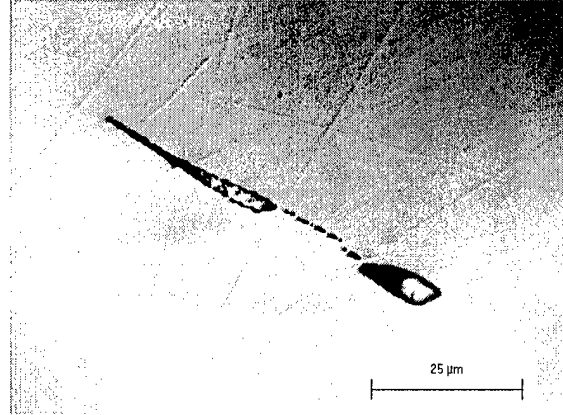

Figure 42: Wafer 6 – Region 2 at 1000x magnification – post 1-hour polish, slurry pH = 11, rpm = 90 condition

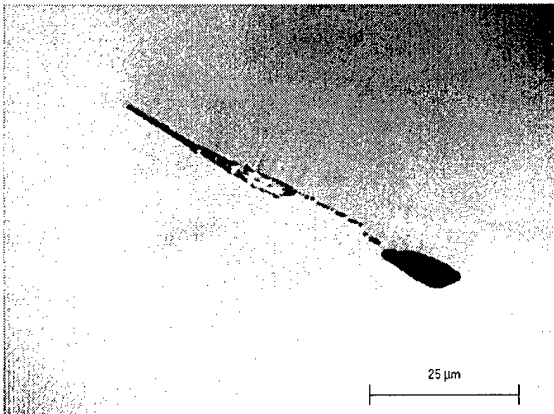

Figure 43: Wafer 6 – Region 2 at 1000x magnification – post 2-hour polish, slurry pH = 11, rpm = 90 condition

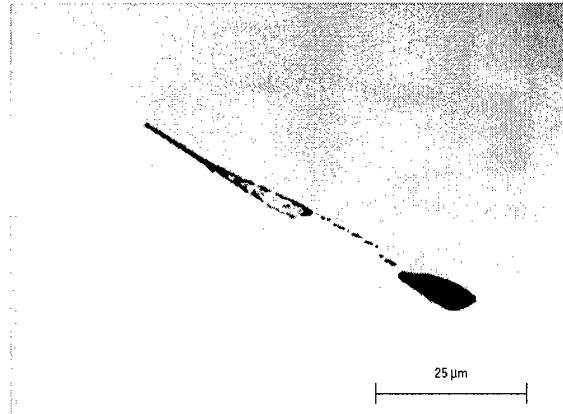

Figure 44: Wafer 6 – Region 2 at 1000x magnification – post 3-hour polish, slurry pH = 11, rpm = 90 condition

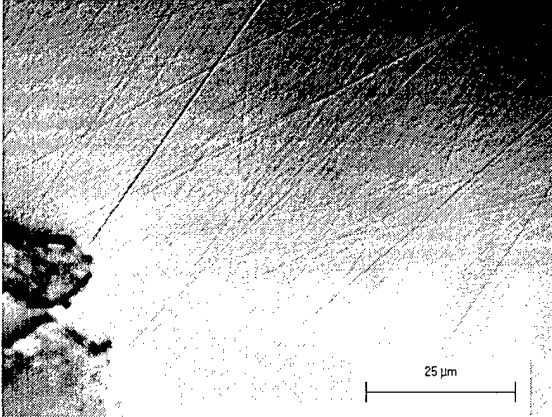

Figure 45: Wafer 6 – Trench 2 at 1000x magnification – pre-polish condition

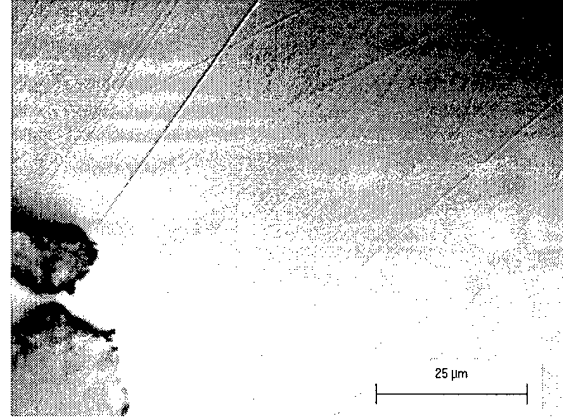

Figure 46: Wafer 6 – Trench 2 at 1000x magnification – post 1-hour polish, slurry pH = 12, rpm = 90 condition

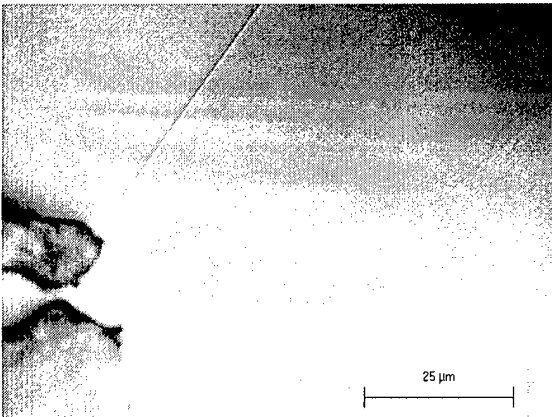

Figure 47: Wafer 6 – Trench 2 at 1000x magnification – post 2-hour polish, slurry pH = 12, rpm = 90 condition

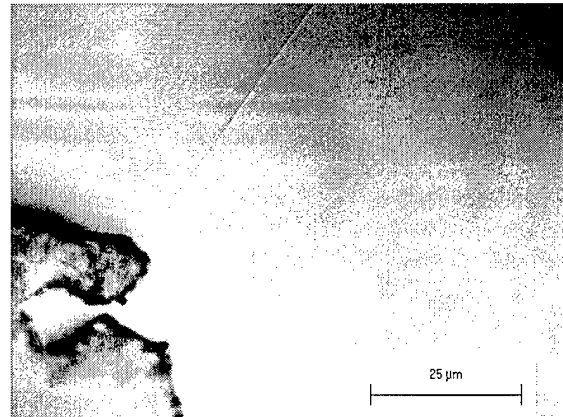

Figure 48: Wafer 6 – Trench 2 at 1000x magnification – post 3-hour polish, slurry pH = 12, rpm = 90 condition

The total calculated material removed during the three hours of polishing at 90 rpm with a 12 pH slurry was 493 angstroms.

A careful examination of Figure 43 will reveal that most of the surface scratches are removed during the second hour of polishing using a slurry of pH 11. Also, except for the deep scratch that is clearly visible, a similar result is observed in Figure 47 after polishing for two hours with a slurry of 12 pH. The photograph taken after polishing for



two hours with a slurry of 9.9 pH (Figure 39) shows scratches that are slightly more visible and numerable when compared to Figures 43 and 47. Thus, the photographs do not seem to conclusively support a higher removal rate data during the second hour using a slurry of pH 11.

Four possible scenarios could explain the high removal rate measured after the second hour of polishing with the slurry of pH 11. First, it is possible Wafer 6 is inhomogeneous through the thickness of the wafer. Although possible, this is extremely unlikely. Second, it is possible that excess silica and silicon carbide particles were embedded in the polishing pad fibers and were not removed during the rinse after the first hour of polishing. The presence of these particles could increase the removal rate of the wafer during the second hour of polishing. However, it is not believed that the presence of extra particles alone could result in a removal rate that is five times the nominal value. Third, a piece of the wafer could have been chipped from the edge during the hour long polish. This is also unlikely since the edge was thoroughly inspected at 100x and 500x magnification after polishing. Finally, the high removal rate could be attributed to a combination of the first three possibilities in conjunction with other polishing parameters that have not yet been considered.

The average removal rates are 236, 171, and 164Å/hour using slurries with pH levels of 9.9, 11, and 12 respectively. The average value for the pH 11 slurry was obtained by neglecting the anomalous removal rate during the second hour. The decrease in average removal rate with increasing pH can be explained by considering the function of the silica particles in the polishing process. The silica particles mechanically remove the 'softened' wafer surface. As increased amounts of 1.25M NaOH solution are added

to the polishing slurry, the percent content of silica particles in the slurry decreases. This, in turn, decreases the probability that a silica particle will abrade the wafer surface. It appears that the large increase in hydroxide concentration does not compensate for the small decrease in polishing particle concentration.

Although it was found that higher pH slurries do not increase removal rate using Logitech SF1 polishing slurry, it is possible that increased pH levels in other polishing solutions could have a different effect.

### **Pressure Study**

Four different pressures were evaluated using as received Logitech slurry at 23°C and 90 rpm. In addition to 5 lb/in<sup>2</sup> which had previously been evaluated, pressures of 7, 9, and 11 lb/in<sup>2</sup> were used to polish Wafer 6. An attempt was made to maintain a thin layer of polishing slurry on the pad during polishing periods. Although successful at 5 lb/in<sup>2</sup>, a thin film of slurry was not possible at higher pressures. An average of 720, 875, and 925 ml/hour of slurry was used while polishing at 7, 9, and 11 lb/in<sup>2</sup> respectively. However, the higher slurry feed rates did not prevent the formation of dry paths on the polishing pad. Levert (Levert et al., 1998, 593) and Tichy (Tichy et al., 1999:1523) found that the pressure between the wafer and a rotating CMP pad was greatest at the center of the wafer. The increased pressure and rotating pad caused the wafer to displace the slurry to its edges thus creating a path on the polishing pad that was void of polishing slurry. Figure 49 illustrates the creation of a dry path on the pad surface by the wafer which introduced additional variation in material removal rates. Figure 50 shows the removal rates that were calculated for 5, 7, 9, and 11 lb/in<sup>2</sup>.

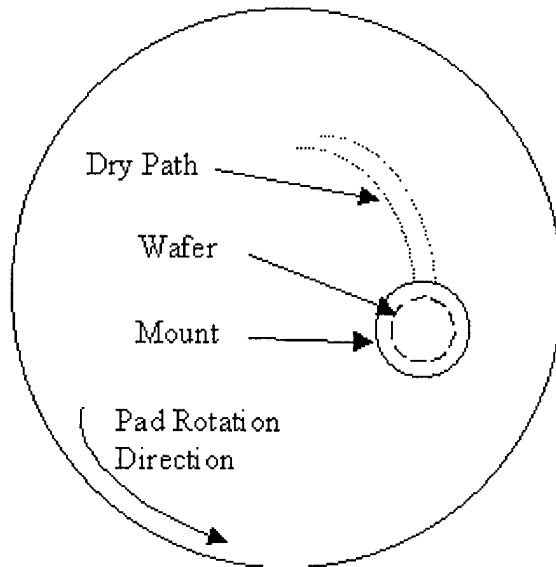

Figure 49: Pad Dry Path Formation

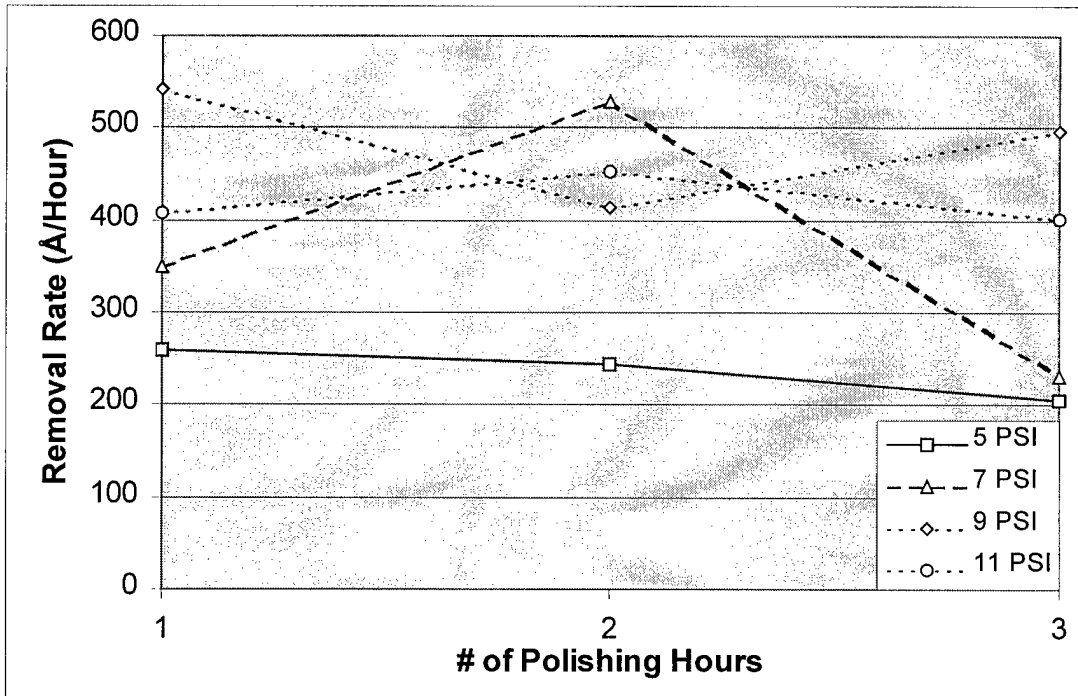

Figure 50: Pressure study at 23°C and 90 rpm

As seen in the plot, an anomalous point was acquired for the second hour of polishing at 7 lb/in<sup>2</sup>. The 528Å removed during this hour appears to be abnormally high and could be due to the variability introduced by the presence of dry paths on the pad at this higher pressure. Fortunately, the calculated removal rates for 9 and 11 lb/in<sup>2</sup> appear to be more consistent. The average removal rates for 5, 7, 9, and 11 lb/in<sup>2</sup> applied pressures are 236, 290, 484, and 421Å/hour respectively. The average for 7 lb/in<sup>2</sup> was obtained by neglecting the high removal rate calculated after the second polishing hour.

Comparison of the averages reveals the simple conclusion that increased pressure increases the removal rate. Of course, this conclusion is in agreement with what one would expect. It is expected that higher pressures would result in a higher removal rate since the wafer is pressed deeper into the pad fibers and contacts more silica particles. It is interesting that the average removal rate at 11 lb/in<sup>2</sup> is less than the average at 9 lb/in<sup>2</sup>. This could be due to damage that the higher pressure induced on the polishing pad.

During polishing periods at 7, 9, and 11 lb/in<sup>2</sup> the polishing pad was damaged. This conclusion was made after observing dark fibers floating on the surface of the slurry during and after polishing the wafer for an hour at these pressures. A greater concentration of fibers was observed for the higher pressures of 9 and 11 lb/in<sup>2</sup>. It is possible that the pressure of 11 lb/in<sup>2</sup> caused enough pad damage to result in decreased removal rates. It should also be noted that different results may be obtained for a different polishing pad. Figures 37 through 40, 51 through 54, 55 through 58, and 59 through 62 are photographs of the wafer surface before and after polishing periods for pressures of 5, 7, 9, and 11 lb/in<sup>2</sup> respectively. Careful examination and comparison will

reveal that the photographs seem to support the general trend of increasing removal rate with increasing pressures.

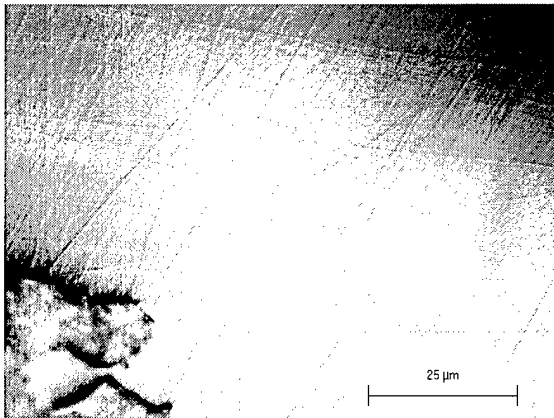

Figure 51: Wafer 6 – Trench 2 at 1000x magnification – pre-polish condition

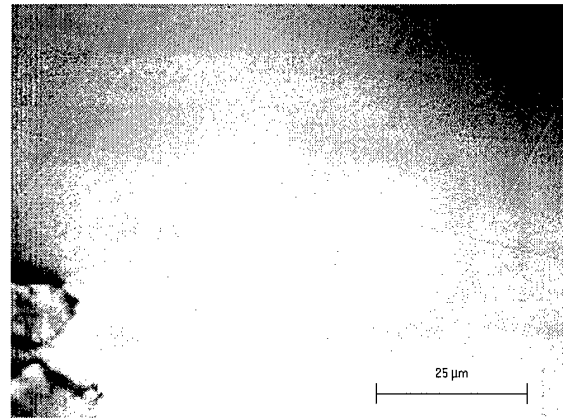

Figure 52: Wafer 6 – Trench 2 at 1000x magnification – post 1-hour polish, pressure = 7 psi, rpm = 90 condition

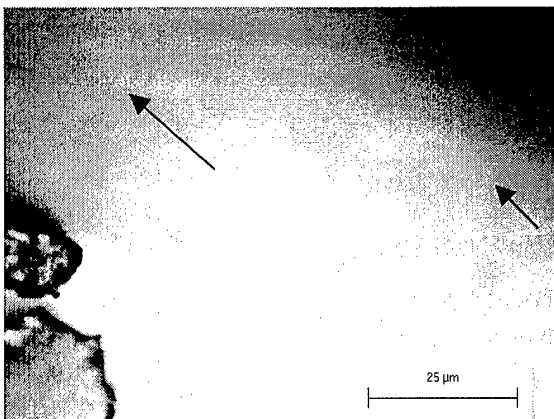

Figure 53: Wafer 6 – Trench 2 at 1000x magnification – post 2-hour polish, pressure = 7 psi, rpm = 90 condition

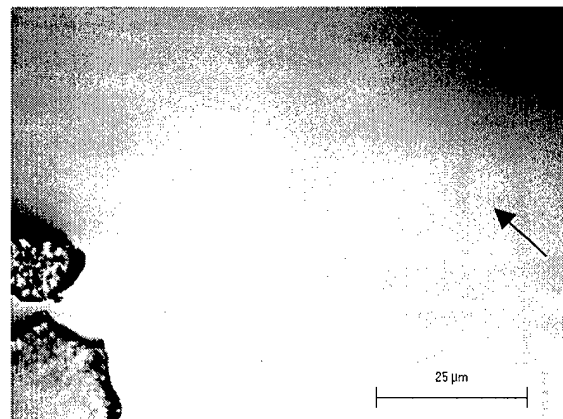

Figure 54: Wafer 6 – Trench 2 at 1000x magnification – post 3-hour polish, pressure = 7 psi, rpm = 90 condition

The arrows in Figures 53 and 54 locate scratches that have almost been removed from the surface during the 3 hours of polishing. The total calculated material removed during the three hours of polishing at 7 lb/in<sup>2</sup> was 1109 angstroms which includes the relatively high value calculated during the second hour of polishing.

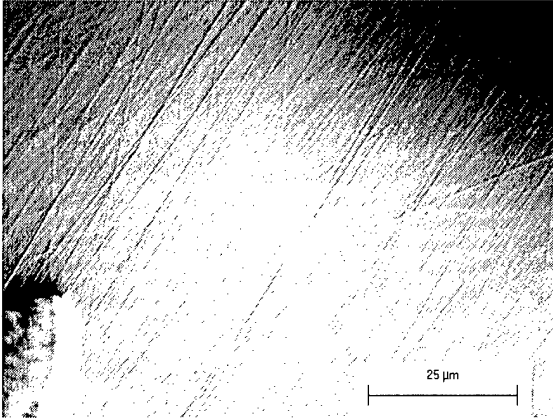

Figure 55: Wafer 6 – Trench 3 at 1000x magnification – pre-polish condition

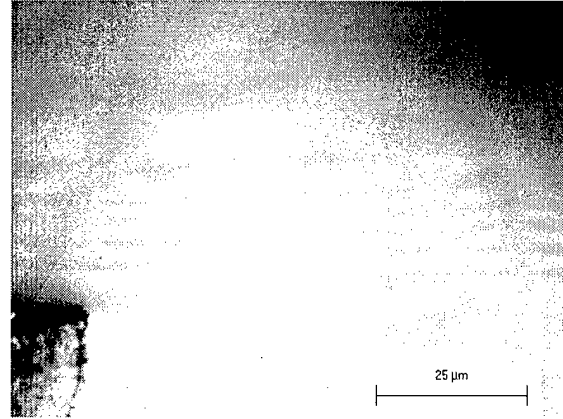

Figure 56: Wafer 6 – Trench 3 at 1000x magnification – post 1-hour polish, pressure = 9 psi, rpm = 90 condition

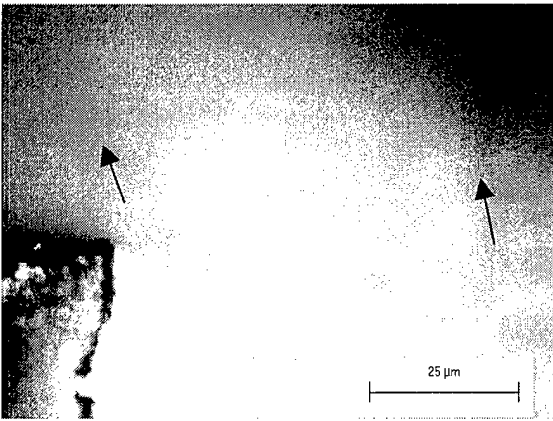

Figure 57: Wafer 6 – Trench 3 at 1000x magnification – post 2-hour polish, pressure = 9 psi, rpm = 90 condition

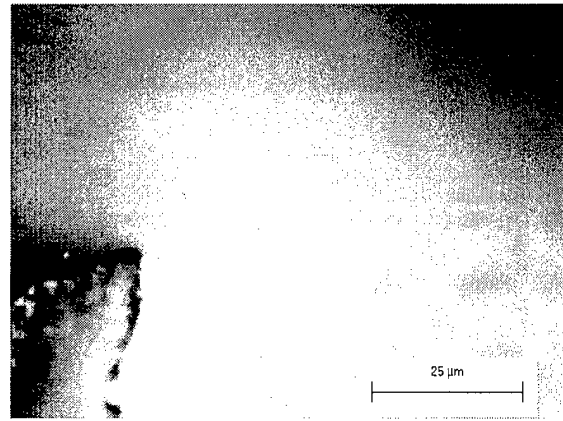

Figure 58: Wafer 6 – Trench 3 at 1000x magnification – post 3-hour polish, pressure = 9 psi, rpm = 90 condition

The faint indications of scratches on the wafer surface can still be seen at the locations specified by the arrows in Figure 57. The total calculated material removed during the three hours of polishing at  $9 \text{ lb/in}^2$  was 1452 angstroms.

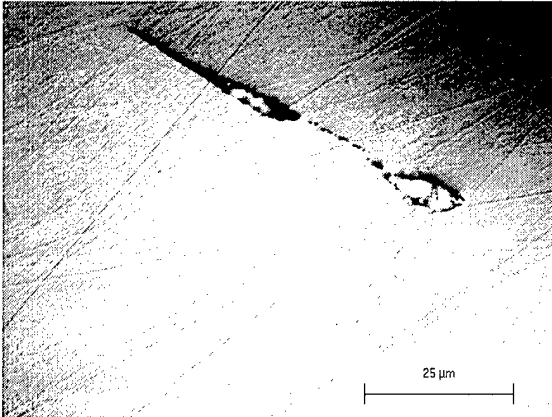

Figure 59: Wafer 6 – Region 2 at 1000x magnification – pre-polish condition

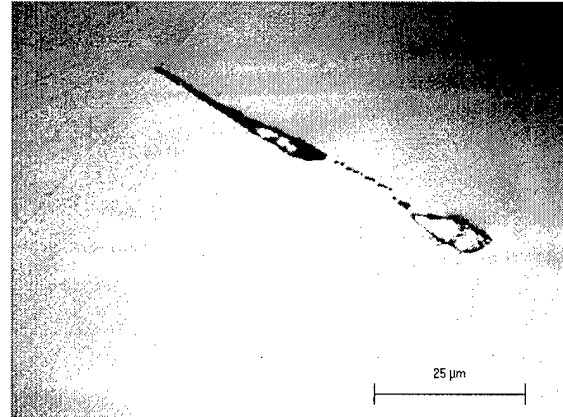

Figure 60: Wafer 6 – Region 2 at 1000x magnification – post 1-hour polish, pressure = 11 psi, rpm = 90 condition

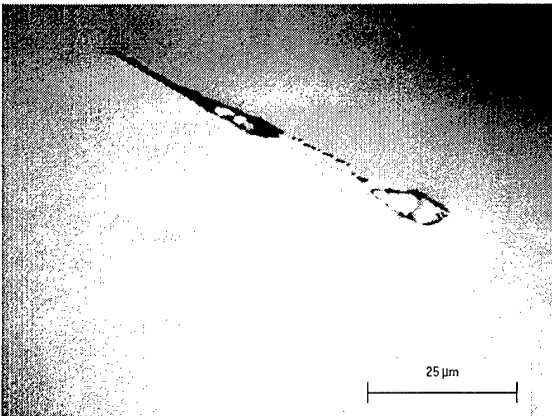

Figure 61: Wafer 6 – Region 2 at 1000x magnification – post 2-hour polish, pressure = 11 psi, rpm = 90 condition

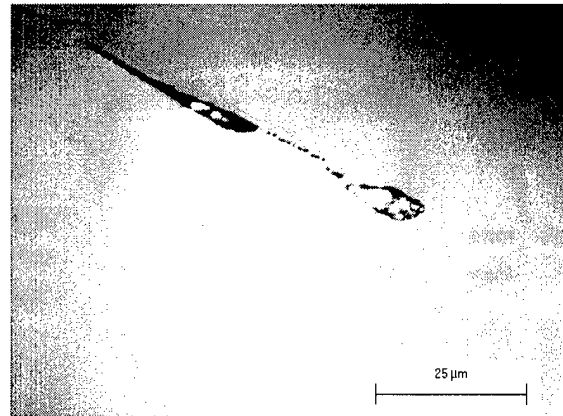

Figure 62: Wafer 6 – Region 2 at 1000x magnification – post 3-hour polish, pressure = 11 psi, rpm = 90 condition

The total calculated material removed during the three hours of polishing at 11 lb/in<sup>2</sup> was 1264 angstroms.

A comparison of photographs taken after three hours of polishing will reveal that increased pressure does indeed seem to help in the removal of surface scratches. While the scratches in Figure 40 are still quite prominent, the scratches in Figures 54, 58, and 62 are very faint to non-existent. Appendix G and J contain additional photographs of the

wafer during 5 and 7 lb/in<sup>2</sup> studies. Additional photographs during 9 and 11 lb/in<sup>2</sup> studies can be found in Appendix K and L.

### **Rotational Speed Study**

A wide range of polishing speeds was studied at room temperature with a pressure of 5 lb/in<sup>2</sup>. Although higher pressures do result in increased removal rates, they also induce damage to the polishing pad fibers. Wafer manufacturers limit their expenditures by reducing the amount of slurry and pads used in preparing the wafers for device applications. Since the higher pressures of 7, 9, and 11 lb/in<sup>2</sup> produce pad damage and would therefore increase manufacturer costs, it was decided that the rotational speed study should be performed at a pressure that produced no visible signs of damage to the polishing pad. Thus, speed studies were conducted at 5 lb/in<sup>2</sup>. In addition, since higher pH levels did not increase material removal rates, as-received Logitech slurry was used.

The following pad speeds were used to polish the wafer: 60, 90, 120, 150, and 180 rpm. For 60 and 90 rpm experiments, the wafer was polished for 60 minute periods. When the speed was increased to 120, 150, and 180 rpm, the polishing period was reduced to 30 minutes. This change in polishing duration was made due to the high amounts of slurry used for the higher rotational speed studies. During 60 and 90 rpm studies, an average of 450 and 750ml of slurry was used for a 60 minute polishing period. For speeds of 120, 150, and 180 rpm, slurry volumes averaged 1300, 1500, and 1750 ml/hour respectively. The increased slurry volumes were used in an effort to maintain a thin film on the polishing pad. During high rotational speeds, most of the slurry was thrown from the pad edge and dry paths were prominent on the pad surface. The presence of dry paths was mitigated by allowing the slurry to flow down the side of the



wafer mount during high speed studies. The slurry was then drawn under the mount and wafer by the moving pad. For slower rotational speeds, dripping the slurry directly on the polishing pad was sufficient to maintain a thin film during the entire polishing period.

Figure 63 is a plot of the removal rates for each of the polishing speeds.

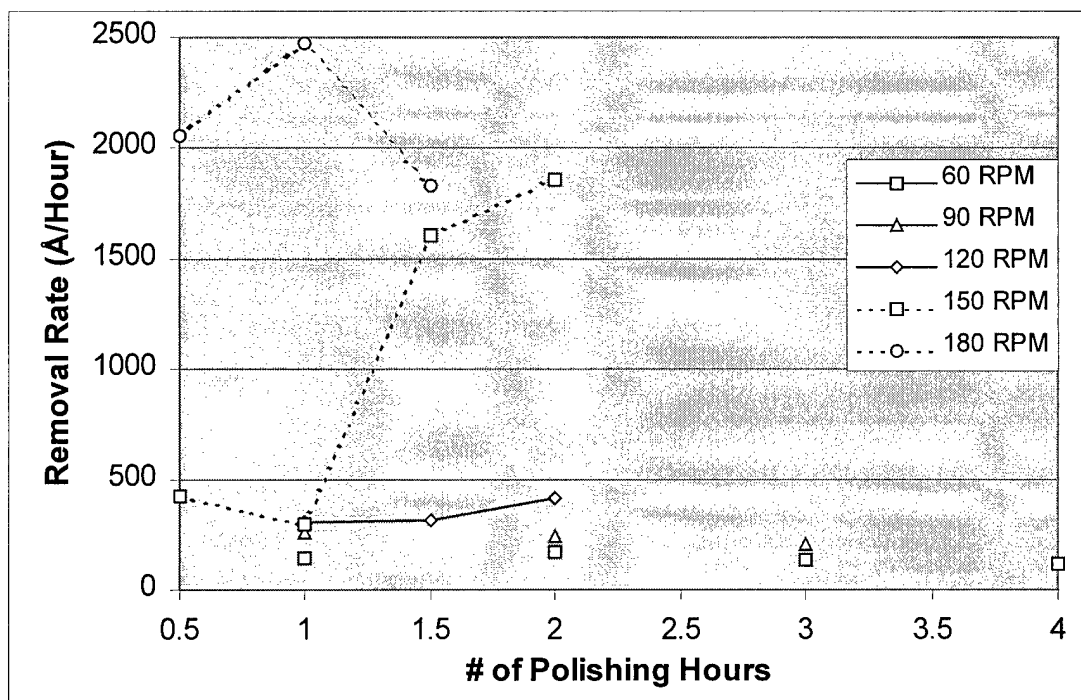

Figure 63: Pad speed study at 23°C and 5 lb/in<sup>2</sup>

The data viewed in Figure 63 is reminiscent of the preliminary data presented in the first section of this chapter. The lower speed values are fairly stable up to and including 120 rpm. At 150 and 180 rpm, the data becomes very unpredictable. In particular, data for 150 rpm is less than 500Å/hour for the first and second 30 minute periods of polishing. The removal rate magically increases to 1,607 and 1,860Å/hour for the third and fourth 30 minute periods. Surprisingly, 180 rpm data appears to be more stable than that obtained from the 150 rpm study. Average removal rates for the various speeds are 139, 236, 347, 1047, and 2119Å/hour for 60, 90, 120, 150, and 180 rpm

respectively. The average for 150 rpm was obtained by using all four data points.

Photographs of the wafer during these studies can be viewed in Figures 23 through 26 for 60 rpm, 37 through 40 for 90 rpm, 64 through 67 for 120 rpm, 68 through 71 for 150 rpm, and 72 through 75 for 180 rpm.

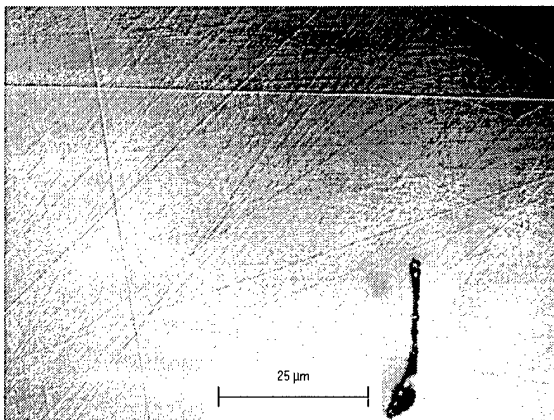

Figure 64: Wafer 5 – Region 1 at 1000x magnification – pre-polish condition

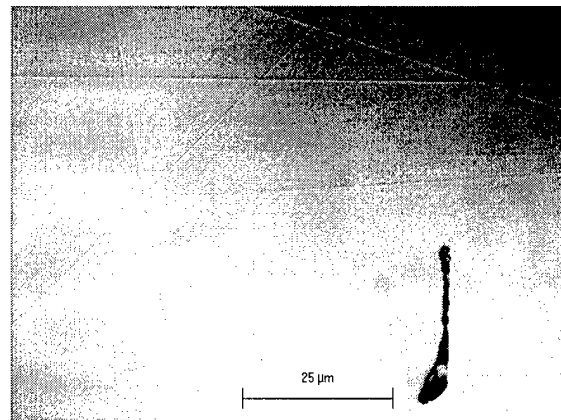

Figure 65: Wafer 5 – Region 1 at 1000x magnification – post 1-hour polish, pressure = 5 psi, rpm = 120 condition

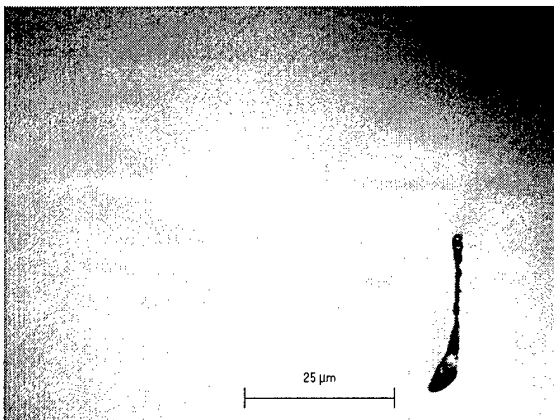

Figure 66: Wafer 5 – Region 1 at 1000x magnification – post 1.5-hour polish, pressure = 5 psi, rpm = 120 condition

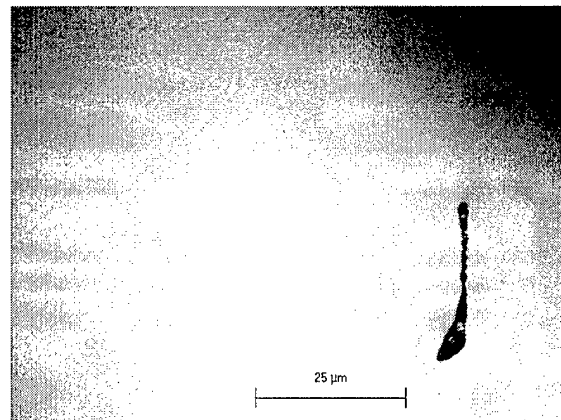

Figure 67: Wafer 5 – Region 1 at 1000x magnification – post 2-hour polish, pressure = 5 psi, rpm = 120 condition

The total calculated material removed during the two hours of polishing at 120 rpm was 677 angstroms.

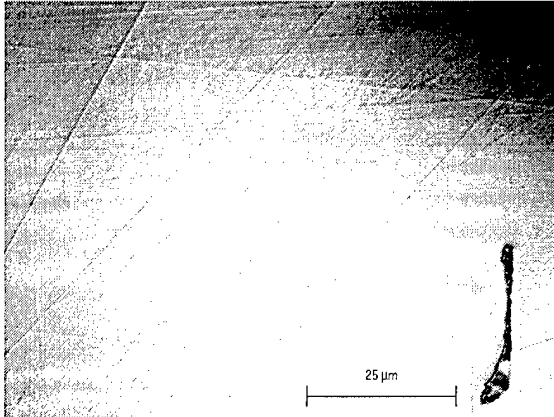

Figure 68: Wafer 5 – Region 1 at 1000x magnification – pre-polish condition

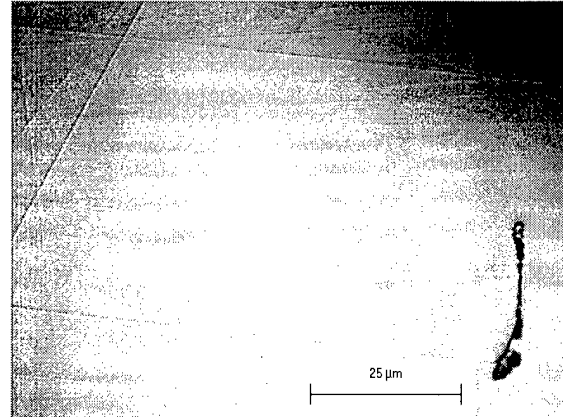

Figure 69: Wafer 5 – Region 1 at 1000x magnification – post 30 minute polish, pressure = 5 psi, rpm = 150 condition

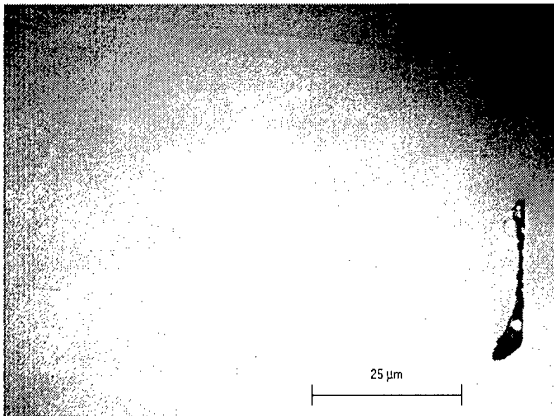

Figure 70: Wafer 5 – Region 1 at 1000x magnification – post 60 minute polish, pressure = 5 psi, rpm = 150 condition

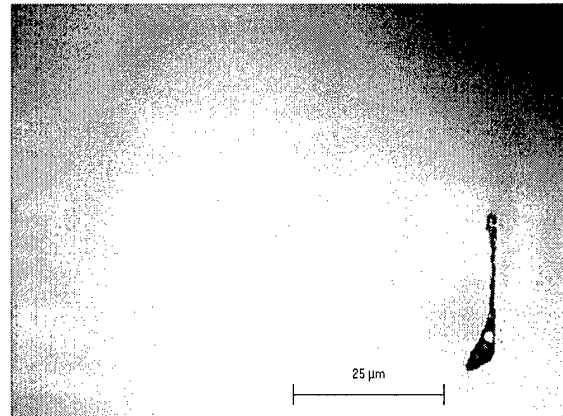

Figure 71: Wafer 5 – Region 1 at 1000x magnification – post 90 minute polish, pressure = 5 psi, rpm = 150 condition

The photograph in Figure 71 was taken after 90 minutes of polishing at 150 rpm.

Although not shown, no surface scratches were visible after digital enlargement of the photograph by 100%. Other areas on the wafer surface were also void of visible surface scratches. The total calculated material removed during the two hours of polishing at 150 rpm was 2094 angstroms.

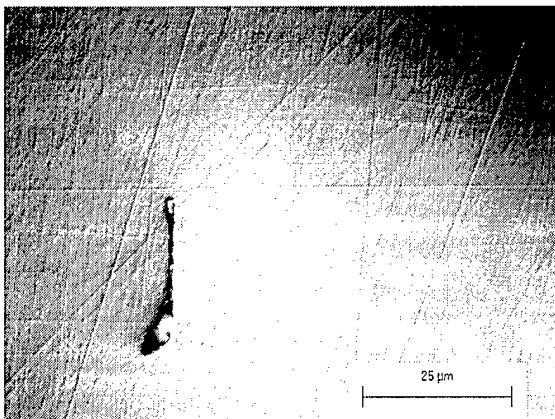

Figure 72: Wafer 5 – Region 1 at 1000x magnification – pre-polish condition

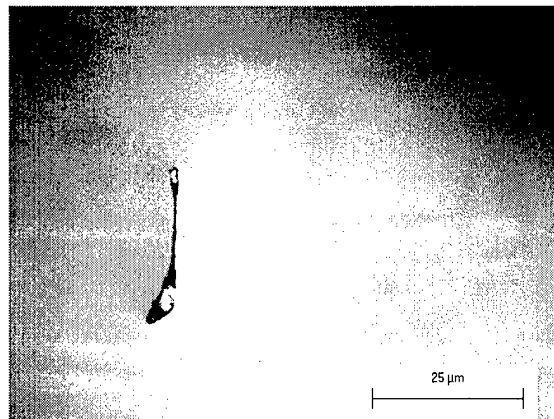

Figure 73: Wafer 5 – Region 1 at 1000x magnification – post 30 minute polish, pressure = 5 psi, rpm = 180 condition

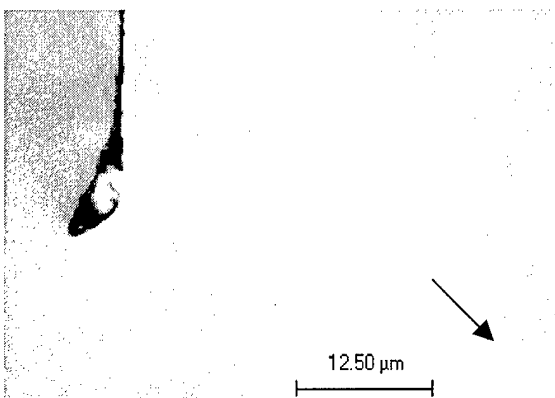

Figure 74: Wafer 5 – Region 1 at 2000x magnification – post 30 minute polish, pressure = 5 psi, rpm = 180 condition

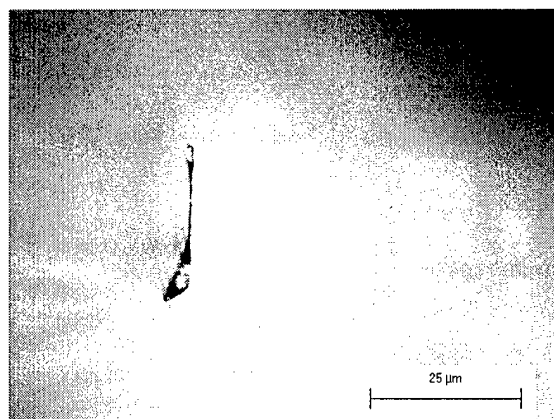

Figure 75: Wafer 5 – Region 1 at 1000x magnification – post 1-hour polish, pressure = 5 psi, rpm = 180 condition

The total calculated material removed during the 90 minutes of polishing at 180 rpm was 3179 angstroms.

The arrow in Figure 74 shows the location of the faint outline of a scratch at 2000x magnification that was still present on the wafer surface after 30 minutes of polishing. Although the microscope was only capable of 1000x magnification, software allowed digital enlargement and enhancement of the image to 2000x magnification. Very few scratches remained on the surface at the photographed regions after this first

polishing period. Again the photographs appear to support the general trend of increasing removal rate with increasing rotational speed. In particular, the photographs of the 180 rpm study indicate that almost all visible scratches at this wafer location were removed after just 30 minutes of polishing. Photographs taken after subsequent periods reveal that additional polishing does not seem to introduce new scratches into the wafer surface. However, residual scratches were observed at other locations on the wafer surface after the three-30 minute polishing periods at 180 rpm.

The variability in removal rates at higher speeds is most likely caused by the absence of a thin film of slurry at all times on the polishing pad surface. Although the pressure is only 5 lb/in<sup>2</sup>, the pad is spinning at a rate high enough to eject most of the slurry from the pad edge. The slurry remaining on the pad is not sufficient to maintain a uniform distribution on the pad at all times. One possible solution to this variability would be to submerge the wafer, polishing substrate and pad surface in a bath of polishing slurry.

### **Optimized Study**

Following studies of the effects of temperature, slurry pH, pressure, and pad rotational speed on removal rate, the optimum value of each parameter was selected for a final polishing study. This final study was conducted at room temperature with 9.9 pH polishing slurry at 5 lb/in<sup>2</sup> and 180 rpm. These polishing parameters had previously been examined during the rotational speed study for three-30 minute polishing intervals. The photographs of this study observed in Figures 72 through 75 indicate that all visible scratches had been removed after 60 minutes of polishing. However, at other locations on the wafer, residual scratches were still visible using optical microscopy after a 90

minute polishing period. This final study was performed as a comparison to previous data and to show that all wafer surface scratches could be removed from the wafer surface with continued CMP.

One difference existed between the previous study at 180 rpm and this final optimized study: the polishing pads used in all of the previous studies were approximately six months old while the polishing pad used in the final study was received from Rodel Inc. several days prior to its use. According to Rodel, the polishing pads have an expiration date of approximately one year after purchase due to the deterioration of the adhesive used to attach the polishing fibers to the polishing pad.

Prior to polishing Wafer 5 at the optimized polishing parameters, surface scratches were re-introduced by polishing with a 3 $\mu$ m diamond polishing solution for 2 minutes. In addition to acquiring optical microscopy images, atomic force microscopy (AFM) height and amplitude images were obtained. Figure 76 is an AFM amplitude image of the surface of Wafer 5 after polishing with the diamond solution.

Measurements using an AFM height image revealed scratches that ranged from 2.4nm deep and 200nm wide for faint scratches to 6.9nm deep and 700nm wide for scratches that appear large in Figure 76. Scratches on the wafer surfaces in the as-received condition from Cree measured as deep as 4.6nm deep and as wide as 430nm. Thus, the 3 $\mu$ m diamond polish created scratches that were somewhat larger than the scratches left by the Cree wafer surface polishing procedures.

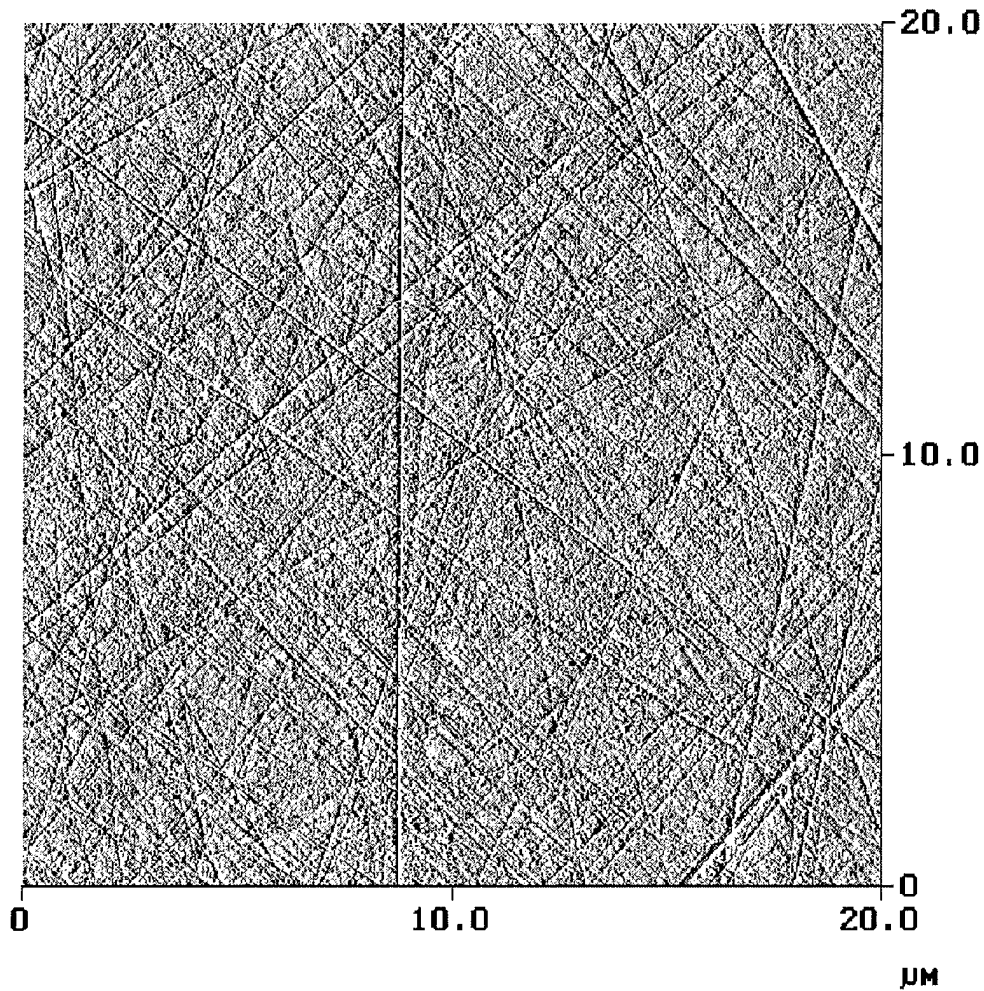

Figure 76: AFM Amplitude Image after re-introducing surface scratches using 3 $\mu$ m diamond polish

After acquiring optical microscopy and AFM images, Wafer 5 was polished at room temperature with 9.9 slurry pH at 5 lb/in<sup>2</sup> and 180 rpm using the recently received polishing pad for a total of three hours. Mass measurements and wafer surface photographs were taken after the first 30, 60 and 90 minutes of the three hour polish. After 2 and 2.5 hours of polishing, the wafer surface was examined, but no mass measurements or photographs were taken. After polishing Wafer 5 for a total of 3 hours, surface scratches were no longer visible at 1000x magnification using optical

microscopy. A final mass measurement was made and the resulting removal rate calculated from this final mass measurement was averaged over the last 90 minutes of polishing. Figure 77 illustrates the removal rates obtained from this final study in comparison to the data acquired during the initial rotational speed study at 180 rpm.

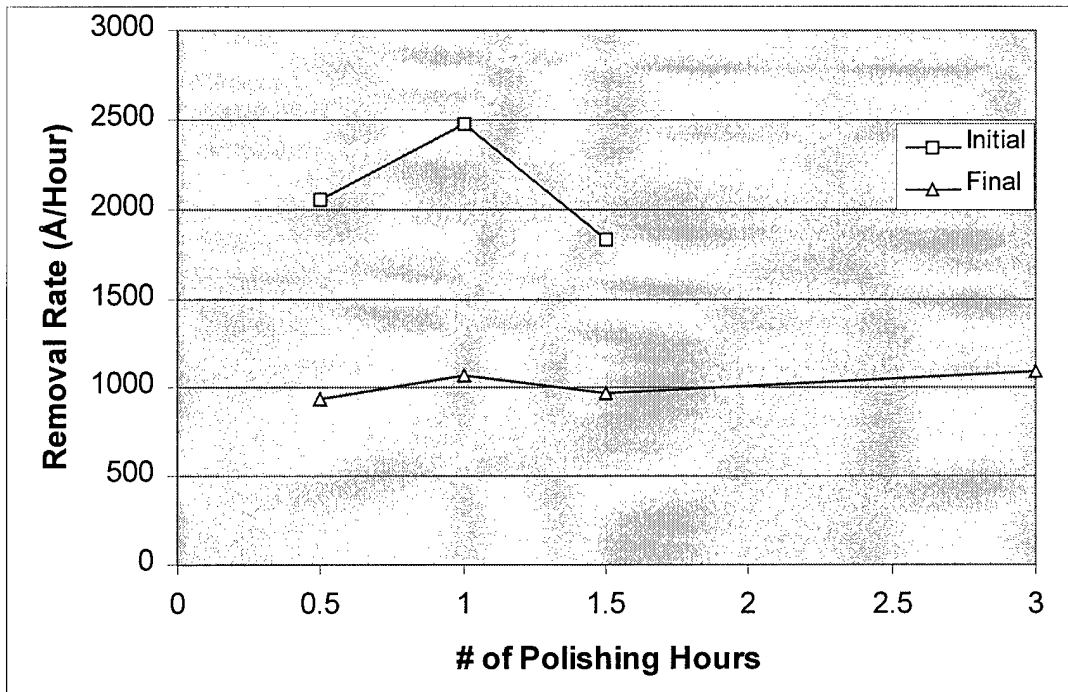

Figure 77: Initial and final study removal rate data at 180rpm

The average removal rate for the initial study over the 90 minute polishing period was 2119 Å/hour. The average removal rate for the final study was 1014Å/hour. This large difference in removal rate between the two studies is one discrepancy that can be observed in Figure 77. The other discrepancy deals with removal rate value variability. During the initial study using the six month old pad, the calculated removal rate varied considerably. In contrast, the optimized study resulted in removal rate data that appears to be more consistent but lower in value. Figures 72 through 75 are photographs acquired during the initial study at 180 rpm. Figures 78 through 81 are 1000x magnification



photographs taken during the final study. Additional photographs during this study can be found in Appendix P. Note that the photographs in Appendix P were taken after many hours of polishing Wafer 5. Although Trench 4 is still approximately 15,000 angstroms deep in these photographs, the polishing process has caused edge rounding so that the trench edges are no longer distinguishable. In these photographs, only the trench edge nearest the center of the wafer is visible.

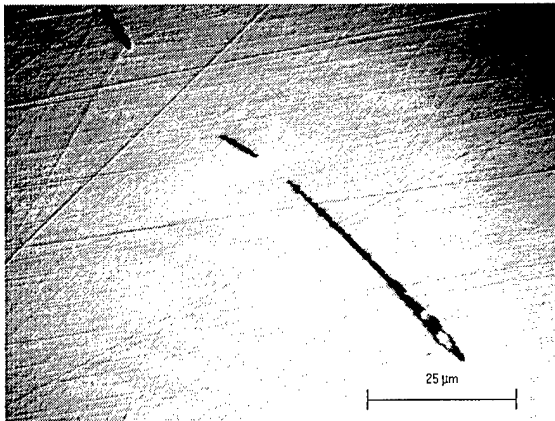

Figure 78: Wafer 5 – Region 1 at 1000x magnification – pre-polish condition

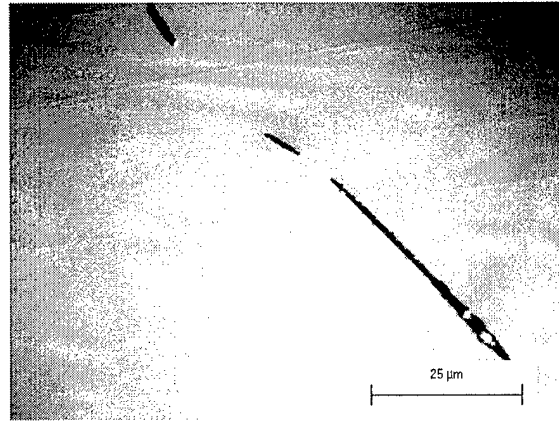

Figure 79: Wafer 5 – Region 1 at 1000x magnification – post 30 minute polish, pressure = 5 psi, rpm = 180 condition

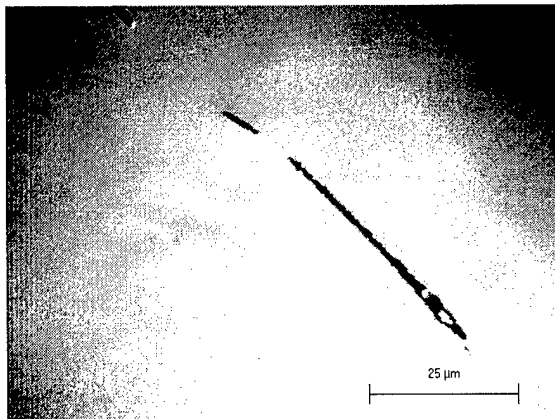

Figure 80: Wafer 5 – Region 1 at 1000x magnification – post 60 minute polish, pressure = 5 psi, rpm = 180 condition

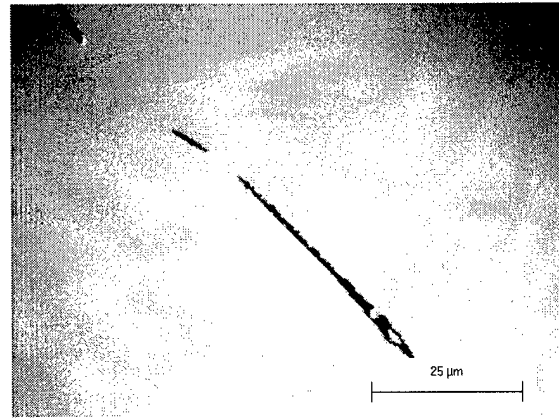

Figure 81: Wafer 5 – Region 1 at 1000x magnification – post 90 minute polish, pressure = 5 psi, rpm = 180 condition

The total calculated material removed during the three hours of this final polishing study at 180 rpm was 3118 angstroms.

Although almost all scratches were removed from this particular location on the wafer surface after only 90 minutes of polishing, several scratches were observed at other wafer locations. Therefore, Wafer 5 was exposed to further CMP until all visible scratches at 1000x magnification were removed. After 3 hours of polishing, a final mass measurement was obtained along with several AFM images. Figure 82 is a typical AFM amplitude image of the surface of Wafer 5 after the optimized study at 180 rpm.

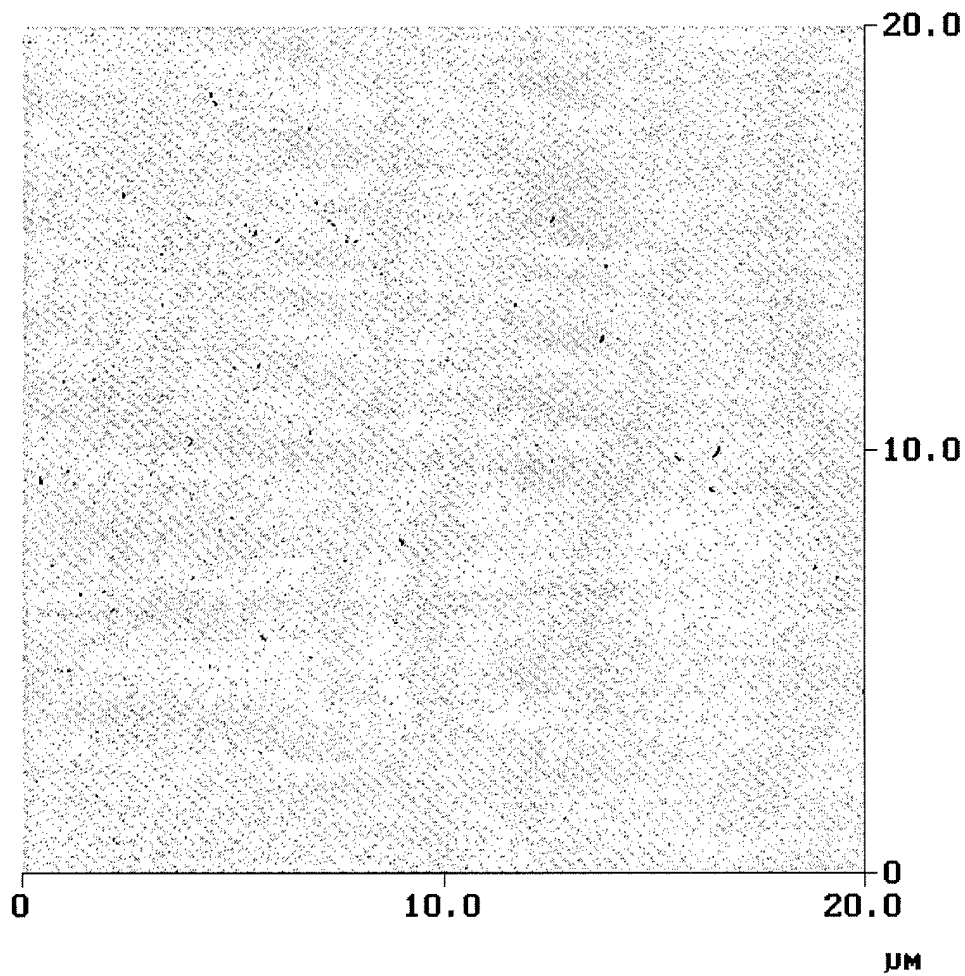

Figure 82: Post 3 hour polish AFM amplitude image

Although Figure 82 does show a regularly spaced pattern across its width, this pattern is attributable to AFM device noise. No indications of scratches were found using AFM imaging techniques. The small particles seen in Figure 82 are sub- $\mu\text{m}$  particles that were found on the wafer surface after the rigorous cleaning procedure. A comparison between Figures 76 and 82 shows that CMP has the capability of removing scratches from the surfaces of SiC wafers.

It is currently unknown why such a large difference in removal rates between the initial and final studies at 180 rpm exists. Rodel Inc. claims that pad age affects the adhesive only and not the polishing fibers. The differences in pad age and pad production lot numbers are the only known differences between the initial and final study parameters. It may be possible that adhesive curing has a positive influence on polishing effectiveness with these particular pads. Certainly it is not expected that the pad production process would produce such a discrepancy but this variable should not be ruled out as a contributing factor.

## V. Conclusions and Recommendations

This study was performed in an effort to decrease the polishing time required to remove all visible scratches from SiC wafers thereby preparing the wafers to be used as substrates in epitaxial growth. During this study, 5 - 1 3/8" Cree wafers from the same boule were chemically mechanically polished for a variety of polishing parameters. Temperature, slurry pH, pressure, and pad rotational speed were the four parameters that were examined. The wafers were polished on a Strasbaugh polishing device using Rodel politex pads and Logitech SF1 polishing solution. Material removal rates were determined from mass measurements before and after each polish using a Mettler scale.

Preliminary experiments conducted at 180 rpm, 3 lb/in<sup>2</sup> and at various temperatures resulted in data that varied dramatically and was extremely random. For example, removal rates varied between 214 and 1131 Å/hour under the same polishing conditions at room temperature. Similar results were observed at higher temperature experiments. Photographs taken before and after each polishing interval supported the variability observed in the calculated removal rates. In an effort to stabilize the randomness of the results, the pad rotational speed was decreased to 60 and 90 rpm and the pressure was increased from 3 to 5 lb/in<sup>2</sup>.

Temperature studies were conducted at 60 rpm using as-received Logitech slurry with a pH of about 9.9 and at temperatures of 23°C and 65°C. The temperature was monitored during the polishing process via a type K thermocouple in direct contact with the back of the SiC wafer. Removal rates were determined after each 60 minute polishing interval. The average removal rate after 4 hours of polishing at 23°C was

139Å/hour while it was only 129Å/hour at 65°C. Thus, it was concluded that increased temperatures do not increase removal rate by expediting chemical reactions between the slurry and wafer surface atoms as Zhou (Zhou et al., 1997:L161) suggests. Rather, the data supported Li's hypothesis (Li et al., 1995:601) that temperature affects the dynamic shear modulus of the pad fibers. The variability of the shear modulus is the property that causes variability in material removal rate.

Slurry pH studies were conducted at 60 and 90rpm at 5 lb/in<sup>2</sup> and 23°C. The series of experiments executed at both of these rotational speeds resulted in the same general trend: decreasing removal rates with increasing slurry pH levels. This observation is in direct conflict with conclusions made by Zhou and Pietsch (Pietsch et al.,1995:1650). The quantities of 1.25M NaOH solution added to increase the slurry pH slightly decreased the volume percent content of the silica particles in the slurry. It is believed that a combination of increased slurry pH levels and the decrease in particle concentration resulted in a decreased removal rate. Although the use of Logitech SF1 polishing solution at higher pH levels did not produce increased removal rates, it is possible that other polishing solutions may result in higher removal rates at increased pH levels.

Four different pressures were evaluated at 23°C and 90 rpm using as-received Logitech slurry (pH = 9.9). As expected, increased pressures of 7, 9, and 11 lb/in<sup>2</sup> resulted in increased removal rates when compared to 5 lb/in<sup>2</sup>. While removal rates over 3 hours averaged 236Å/hour at 5 lb/in<sup>2</sup>, these increased to as much as 484Å/hour at

9 lb/in<sup>2</sup>. However, the higher pressures also caused pad fiber damage that was observed as black fibers floating on the slurry film surface during and after each polishing session. In addition, the average removal rate at 11 lb/in<sup>2</sup> was actually lower than the average at 9 lb/in<sup>2</sup>. It is believed that this decrease in removal rate resulted from additional pad damage observed at 11 lb/in<sup>2</sup>.

Five different polishing speeds were analyzed for effectiveness in increasing material removal rates. This particular set of experiments produced the most dramatic difference in calculated removal rate. The average removal rate observed at 60 rpm was 139Å/hour and increased to an average of 2119Å/hour at 180 rpm. The increase in removal rate for pad speeds of 60, 90, 120, 150, and 180 rpm was not a linear one as the Preston equation suggests in silicon polishing. Unfortunately, in addition to increased removal rates, higher speeds also resulted in greater removal rate variability for a given set of polishing parameters. It is believed that this variability is caused by non-uniform slurry distribution on the pad surface. At lower speeds and pressures, a thin film of slurry was maintained on the pad surface. At higher speeds (120 rpm and higher) and pressures (7 lb/in<sup>2</sup> and higher) maintainability of the thin slurry film was no longer possible.

Although this study revealed several important features of CMP of SiC, these observations are only preliminary. Additional research is necessary to discover a polishing recipe that will minimize polishing time and costs. It is believed that alternative polishing slurries make up a parameter that has great impact on the polishing process and should be explored. Also, increased concentrations of polishing particles should be examined. It is expected that increased particle concentrations will result in

higher removal rates. Additional pad studies would be helpful in determining the effects of pad age and rotational speed on removal rate variability and the time needed to prepare a scratch free substrate.

## Appendix A: Reactive Ion Etch Procedure

1. Thoroughly clean the wafer with acetone and q-tips.
2. Using vacuum sputtering techniques, deposit a gold film of approximately 5000 angstroms thick on the wafer surface.
3. Apply a 1.8 $\mu\text{m}$  thick film of photo-resist (S1418-J2) to completely cover the gold film.
4. Lay the photomask with the desired pattern on the surface of the photoresist.
5. Expose the wafer to ultraviolet light for approximately 20 seconds.
6. Remove the photomask and develop the pattern.
7. Clean the wafer surface with distilled water.
8. Etch the exposed gold with a tri-iodide solution.
9. Clean the wafer surface with distilled water and dry with nitrogen gas.
10. Place the wafer in a vacuum chamber and plasma etch the pattern on the exposed wafer surface at 100 watts for approximately 1 hour.



## **Appendix B: Wafer Attachment Procedure**

1. Preheat the wafer, mount, and pitch on a hot plate. Ensure the temperature of the plate does not cause the pitch to vaporize as this will degrade the quality of the pitch.
2. Apply a thin layer of pitch to the center of the mount ensuring that the temperature is high enough to produce an almost water-like consistency of pitch on the mount surface but not high enough to vaporize the pitch.
3. Using a heat gun, apply heat for several seconds to the pitch on the mount surface to even the distribution of pitch on the mount.
4. Carefully place the wafer in the center of the mount.
5. Carefully remove the mount from the hot plate.
6. Place several layers of lens tissue over the wafer.
7. Place a small amount of weight (approximately 1 lb/in<sup>2</sup>) onto the lens tissue directly over the wafer.
8. Allow the wafer and mount to cool.
9. Remove the weight and lens tissue from the wafer.
10. Using cotton balls and Trichloroethylene, carefully remove the excess pitch surrounding the wafer.
11. Using q-tips and Trichlorethylene, carefully clean the surface of the wafer of all visible pitch.
12. Using q-tips and Acetone, thoroughly clean the wafer surface of any remaining contaminants.

### Appendix C: Wafer Cleaning Procedure

1. After removing the polished wafer from the wafer mount, submerge the wafer in a container of acetone. Physical contact of the hands with the wafer should be avoided. Handle the wafer with tweezers.
2. Remove the wafer from the acetone bath and clean all visible pitch residue from the wafer using a cotton ball and acetone.
3. Carefully place the wafer in a container of trichloroethylene and place the container in an ultrasonic cleaner for 10 minutes.
4. Remove the wafer from the trichloroethylene filled container and submerge in an acetone bath.
5. Remove the wafer from the acetone bath and submerge in an isopropyl alcohol bath.
6. While slowly extracting the wafer from the isopropyl alcohol bath, lightly blow room temperature air over the wafer using a heat gun. The rate of wafer extraction should match the rate at which the alcohol evaporates from the wafer surface.
7. Using clean q-tips and acetone, thoroughly clean the wafer.
8. Repeat steps 3 through 6.
9. The wafer is now prepared for mass measurements.

**Appendix D: Wafer 5 - Temperature Study (23°C)**

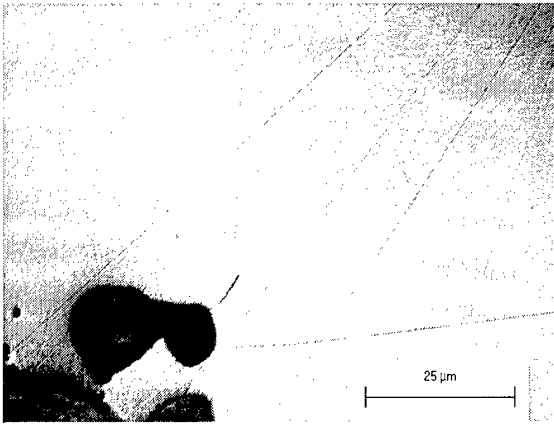

Wafer 5 – Trench 2 at 1000x magnification  
– pre polish, TC temperature = 23°C  
condition

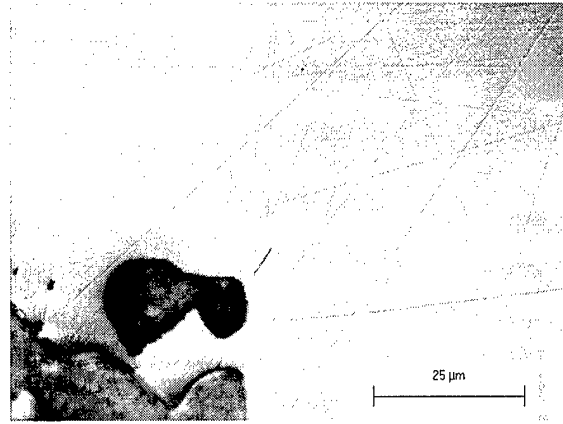

Wafer 5 – Trench 2 at 1000x magnification  
– post 1-hour polish, TC temperature =  
23°C condition

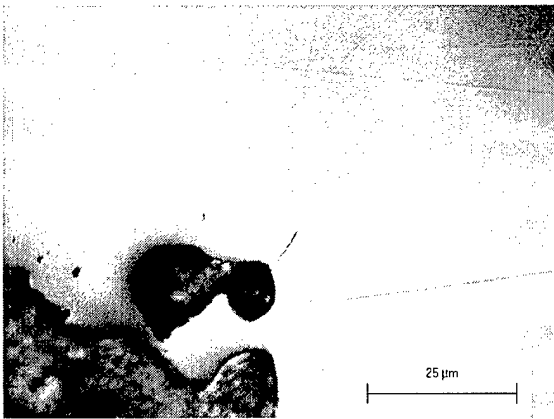

Wafer 5 – Trench 2 at 1000x magnification  
– post 2-hour polish, TC temperature =  
23°C condition

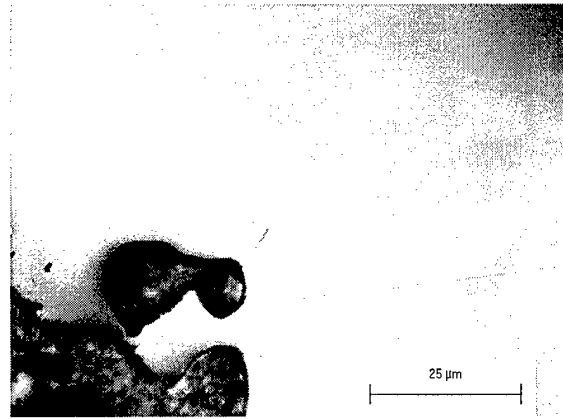

Wafer 5 – Trench 2 at 1000x magnification  
– post 3-hour polish, TC temperature =  
23°C condition

**Appendix E: Wafer 5 - Temperature Study (65°C)**

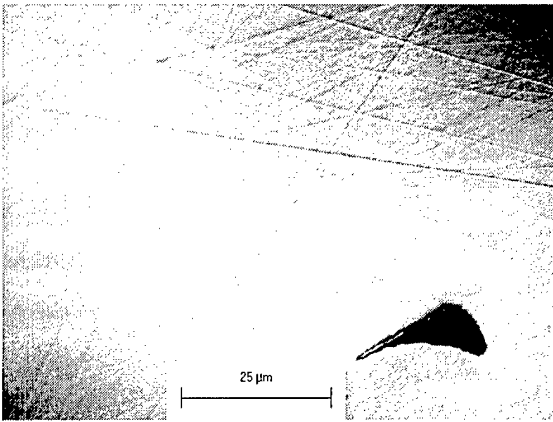

Wafer 5 – Region 3 at 1000x magnification  
– pre-polish, TC temperature = 65°C  
condition

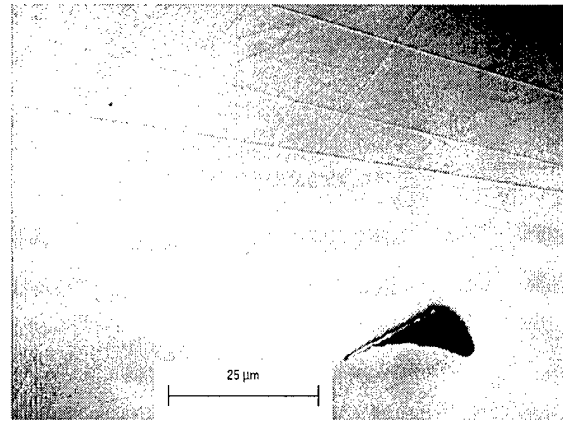

Wafer 5 – Region 3 at 1000x magnification  
– post 1-hour polish, TC temperature =  
65°C condition

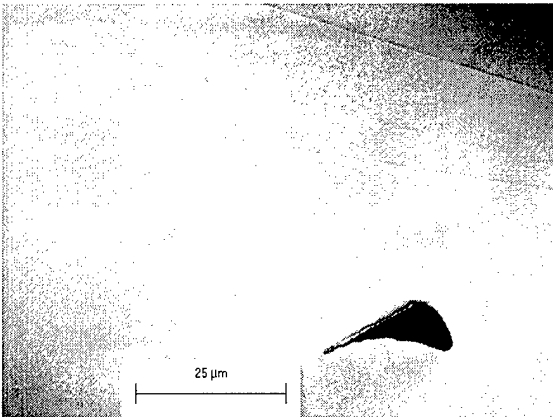

Wafer 5 – Region 3 at 1000x magnification  
– post 2-hour polish, TC temperature =  
65°C condition

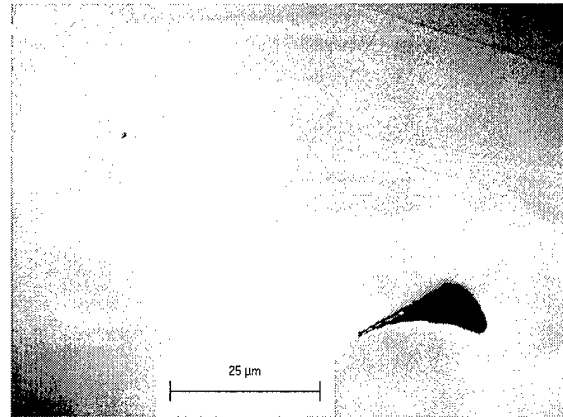

Wafer 5 – Region 3 at 1000x magnification  
– post 3-hour polish, TC temperature =  
65°C condition

**Appendix F: Wafer 5 - pH 11 Study at 60rpm**

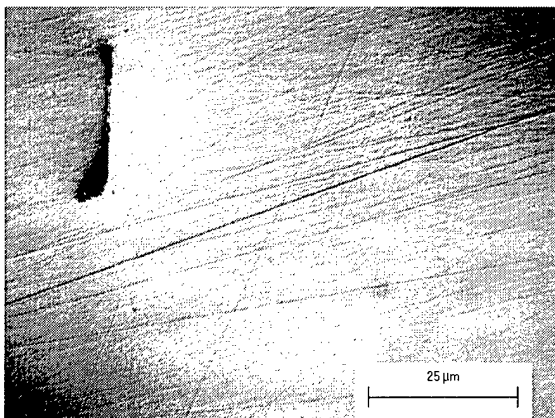

Wafer 5 – Region 1 at 1000x magnification  
– pre-polish, slurry pH = 11, rpm = 60  
condition

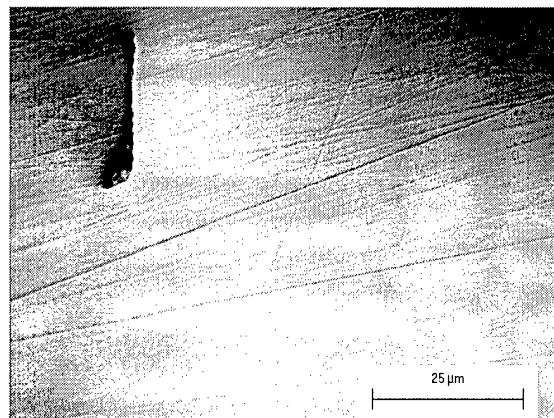

Wafer 5 – Region 1 at 1000x magnification  
– post 1-hour polish, slurry pH = 11,  
rpm = 60 condition

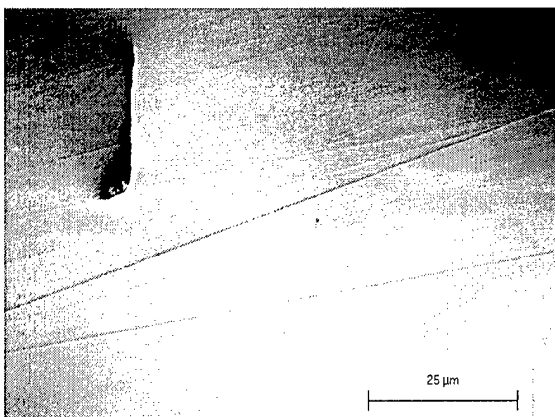

Wafer 5 – Region 1 at 1000x magnification  
– post 2-hour polish, slurry pH = 11,  
rpm = 60 condition

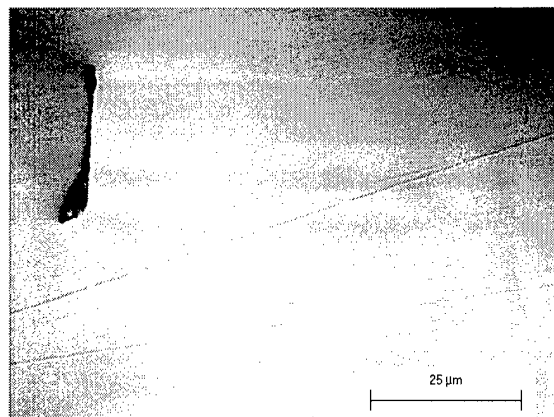

Wafer 5 – Region 1 at 1000x magnification  
– post 3-hour polish, slurry pH = 11,  
rpm = 60 condition

**Appendix G: Wafer 5 - 90rpm Study at 5 lb/in<sup>2</sup>**

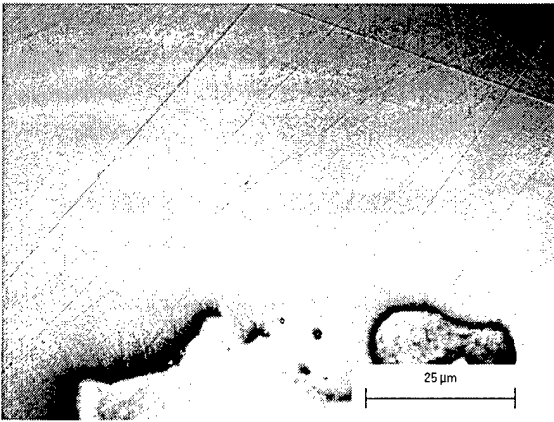

Wafer 5 – Trench 2 at 1000x magnification  
– pre-polish, slurry pH = 9.9,  
rpm = 90 condition

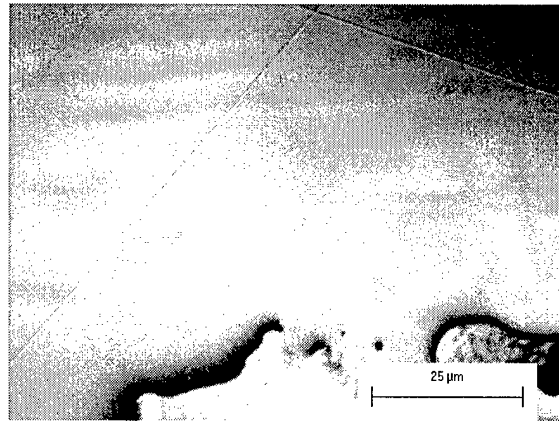

Wafer 5 – Trench 2 at 1000x magnification  
– post 1-hour polish, slurry pH = 9.9,  
rpm = 90 condition

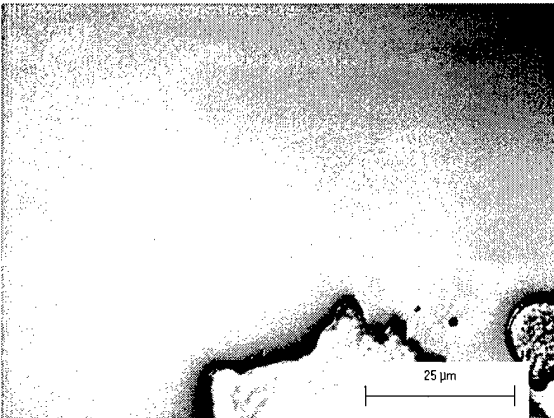

Wafer 5 – Trench 2 at 1000x magnification  
– post 2-hour polish, slurry pH = 9.9,  
rpm = 90 condition

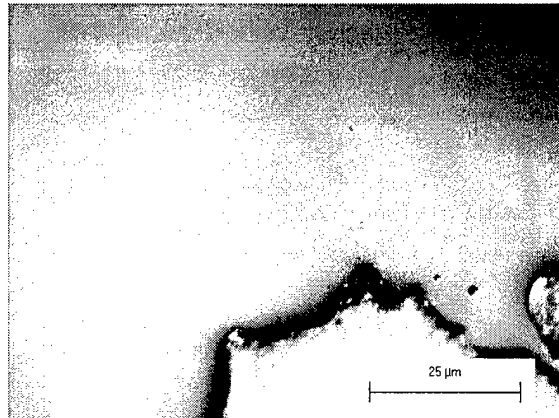

Wafer 5 – Trench 2 at 1000x magnification  
– post 3-hour polish, slurry pH = 9.9,  
rpm = 90 condition

Appendix H: Wafer 6 - pH 11 Study at 90rpm

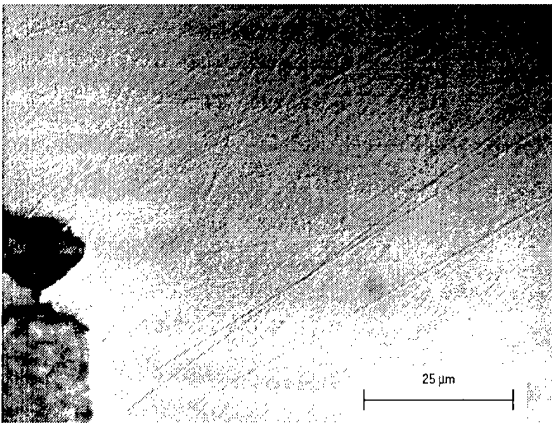

Wafer 6 – Trench 4 at 1000x magnification  
– pre- polish, slurry pH = 11,  
rpm = 90 condition

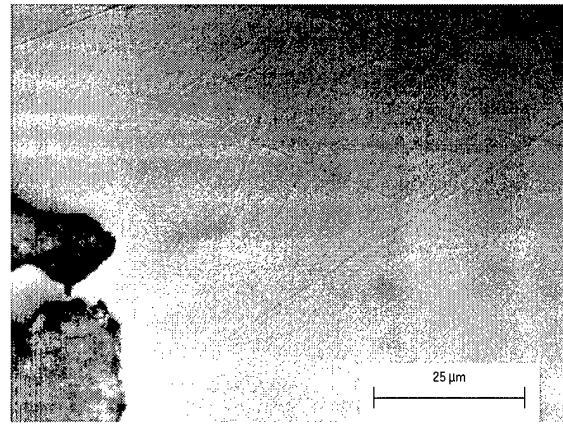

Wafer 6 – Trench 4 at 1000x magnification  
– post 1-hour polish, slurry pH = 11,  
rpm = 90 condition

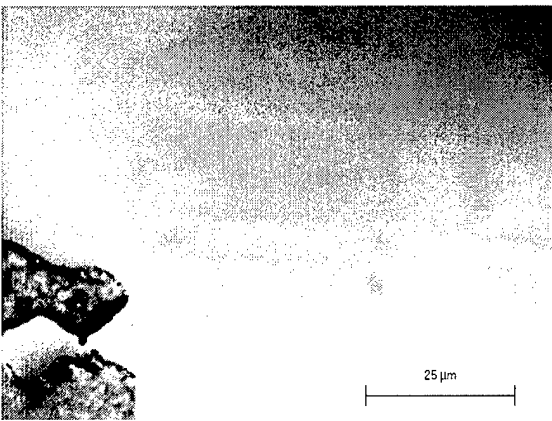

Wafer 6 – Trench 4 at 1000x magnification  
– post 2-hour polish, slurry pH = 11,  
rpm = 90 condition

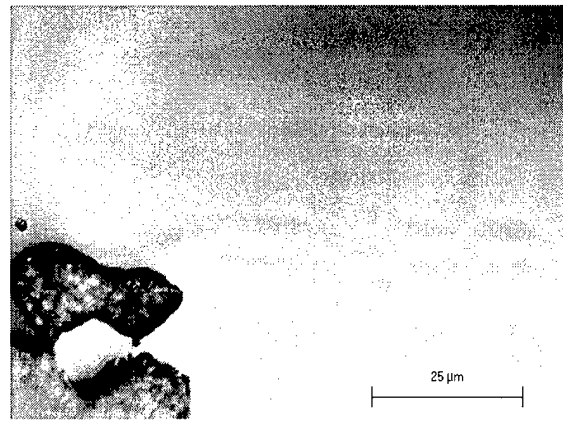

Wafer 6 – Trench 4 at 1000x magnification  
– post 3-hour polish, slurry pH = 11,  
rpm = 90 condition

Appendix I: Wafer 6 - pH 12 Study at 90rpm

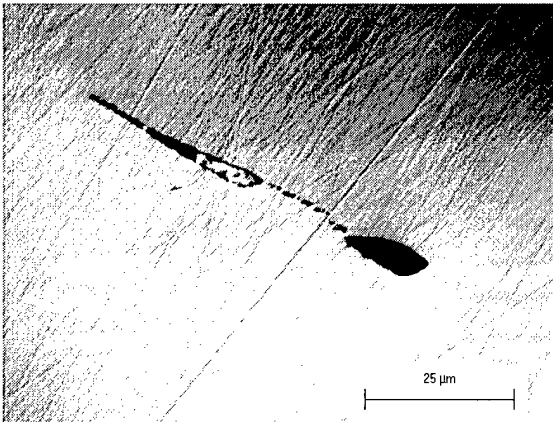

Wafer 6 – Region 2 at 1000x magnification  
– pre-polish, slurry pH = 12,  
rpm = 90 condition

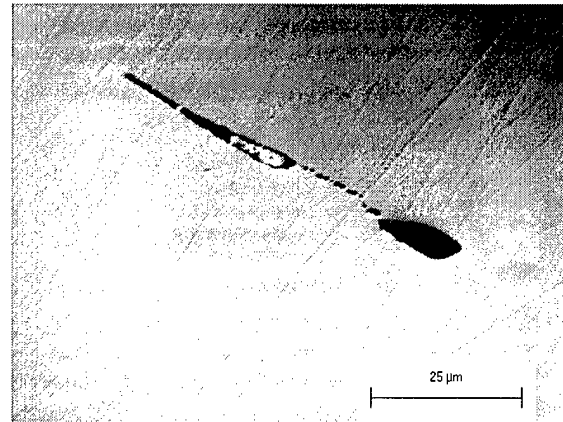

Wafer 6 – Region 2 at 1000x magnification  
– post 1-hour polish, slurry pH = 12,  
rpm = 90 condition

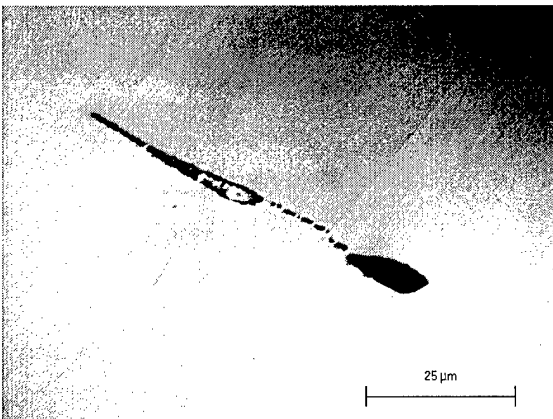

Wafer 6 – Region 2 at 1000x magnification  
– post 2-hour polish, slurry pH = 12,  
rpm = 90 condition

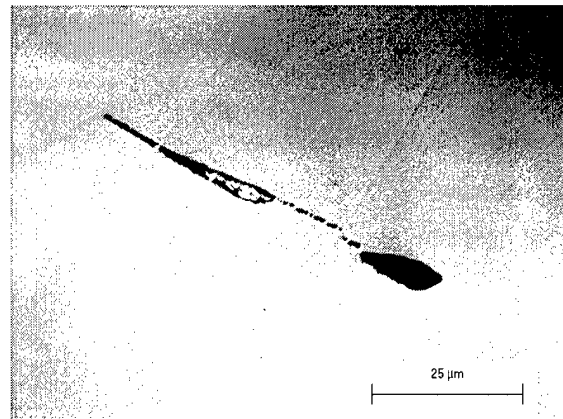

Wafer 6 – Region 2 at 1000x magnification  
– post 3-hour polish, slurry pH = 12,  
rpm = 90 condition



**Appendix J: Wafer 6 - 7lb/in<sup>2</sup> Study at 90rpm**

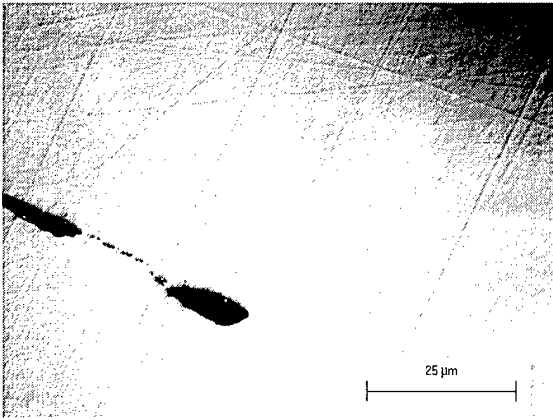

Wafer 6 – Region 2 at 1000x magnification  
– pre-polish, pressure = 7 lb/in<sup>2</sup>,  
rpm = 90 condition

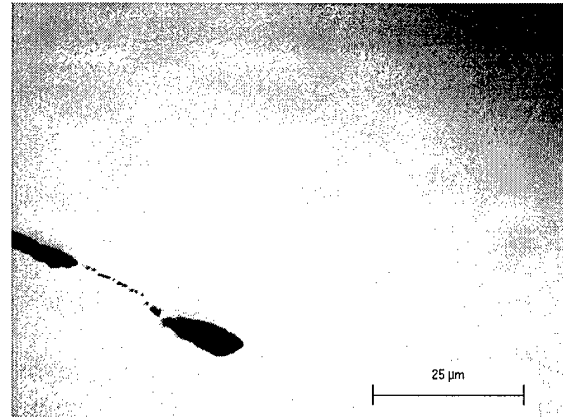

Wafer 6 – Region 2 at 1000x magnification  
– post 1-hour polish, pressure = 7 lb/in<sup>2</sup>,  
rpm = 90 condition

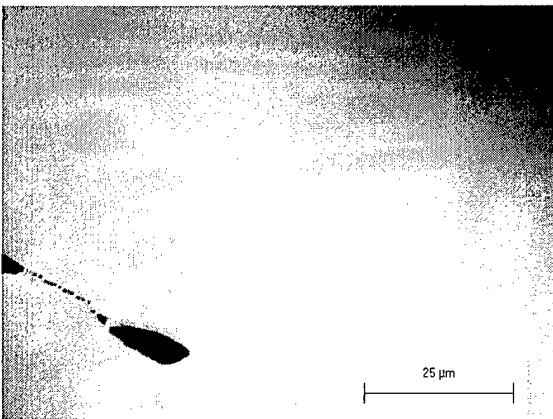

Wafer 6 – Region 2 at 1000x magnification  
– post 2-hour polish, pressure = 7 lb/in<sup>2</sup>,  
rpm = 90 condition

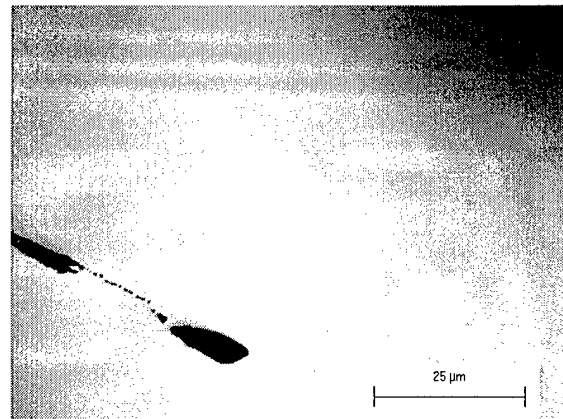

Wafer 6 – Region 2 at 1000x magnification  
– post 3-hour polish, pressure = 7 lb/in<sup>2</sup>,  
rpm = 90 condition

Appendix K: Wafer 6 - 9lb/in<sup>2</sup> Study at 90rpm

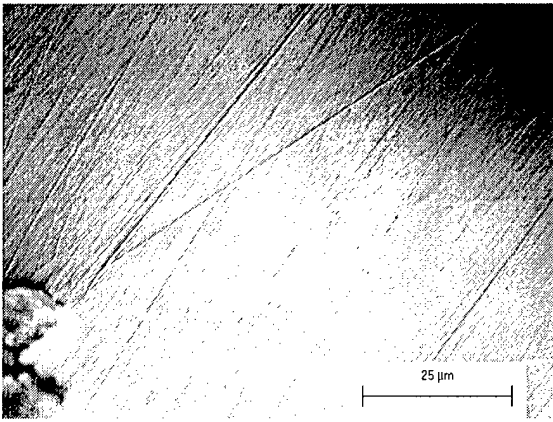

Wafer 6 – Trench 4 at 1000x magnification  
– pre- polish, pressure = 9 lb/in<sup>2</sup>,  
rpm = 90 condition

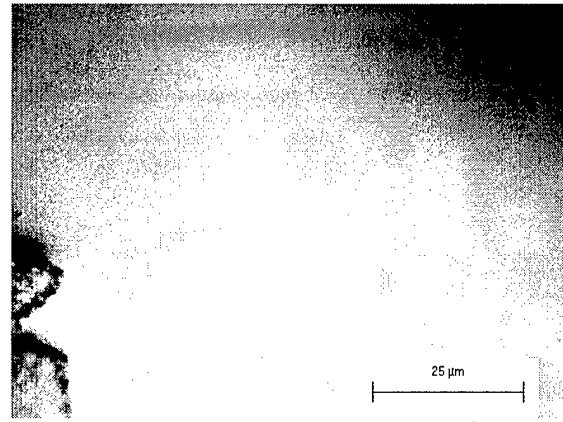

Wafer 6 – Trench 4 at 1000x magnification  
– post 1-hour polish, pressure = 9 lb/in<sup>2</sup>,  
rpm = 90 condition

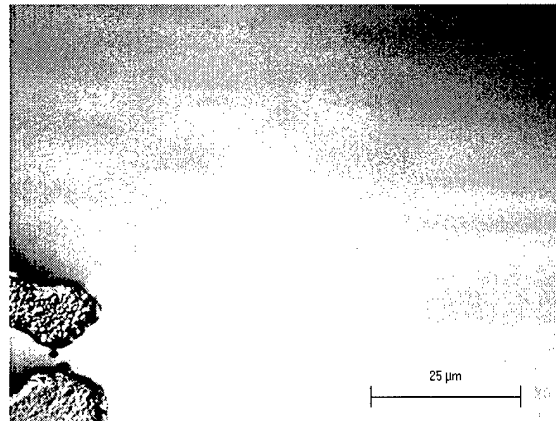

Wafer 6 – Trench 4 at 1000x magnification  
– pre- polish, pressure = 9 lb/in<sup>2</sup>,  
rpm = 90 condition

Appendix L: Wafer 6 – 11lb/in<sup>2</sup> Study at 90rpm

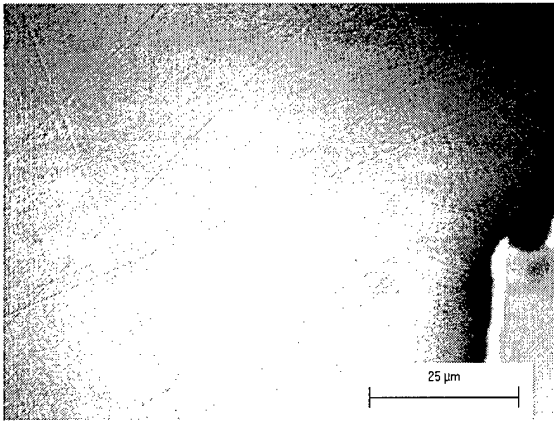

Wafer 6 – Trench 4 at 1000x magnification  
– pre-polish, pressure = 11 lb/in<sup>2</sup>,  
rpm = 90 condition

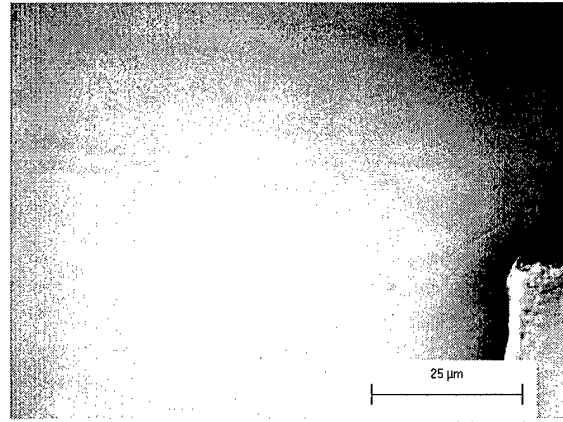

Wafer 6 – Trench 4 at 1000x magnification  
– post 1-hour polish, pressure = 11 lb/in<sup>2</sup>,  
rpm = 90 condition

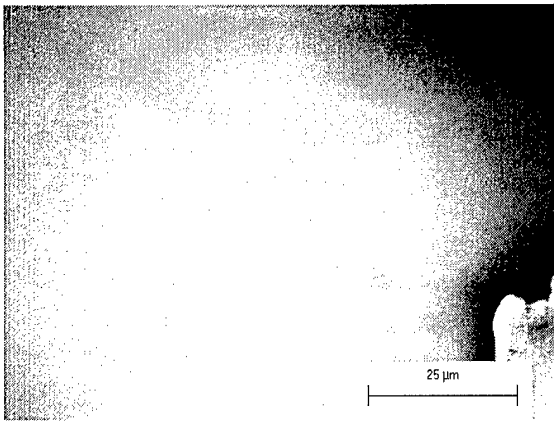

Wafer 6 – Trench 4 at 1000x magnification  
– post 2-hour polish, pressure = 11 lb/in<sup>2</sup>,  
rpm = 90 condition

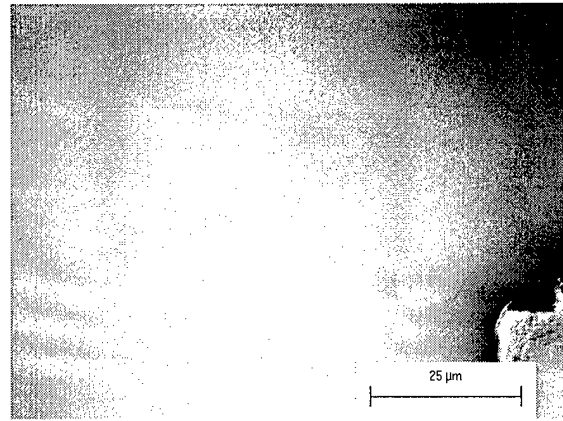

Wafer 6 – Trench 4 at 1000x magnification  
– post 3-hour polish, pressure = 11 lb/in<sup>2</sup>,  
rpm = 90 condition

Appendix M: Wafer 6 – 120rpm Study at 5lb/in<sup>2</sup>

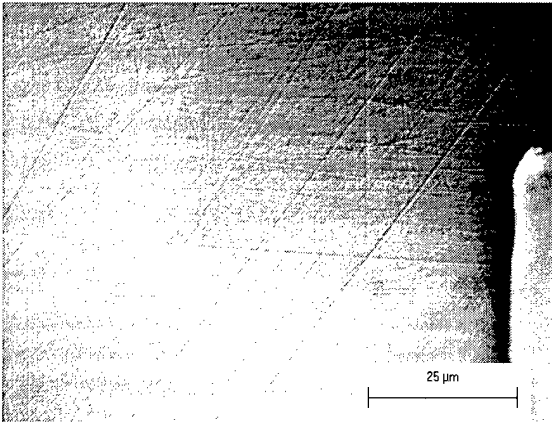

Wafer 6 – Trench 4 at 1000x magnification  
– pre- polish, pressure = 5 lb/in<sup>2</sup>,  
rpm = 120 condition

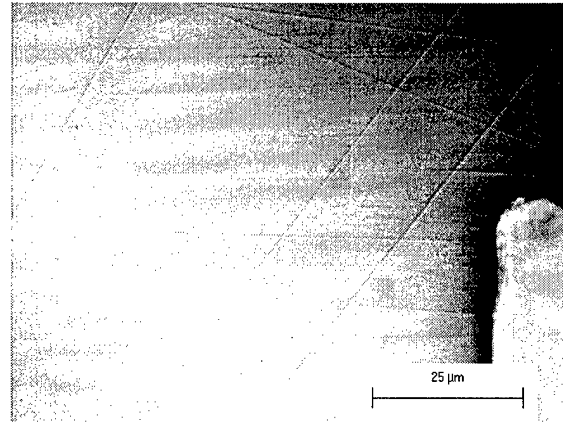

Wafer 6 – Trench 4 at 1000x magnification  
– post 1-hour polish, pressure = 5 lb/in<sup>2</sup>,  
rpm = 120 condition

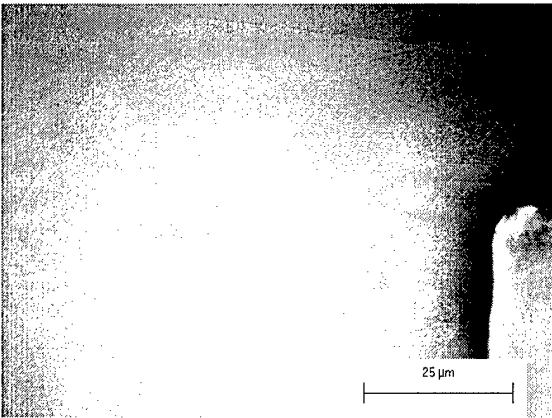

Wafer 6 – Trench 4 at 1000x magnification  
– post 1.5 hour polish, pressure = 5 lb/in<sup>2</sup>,  
rpm = 120 condition

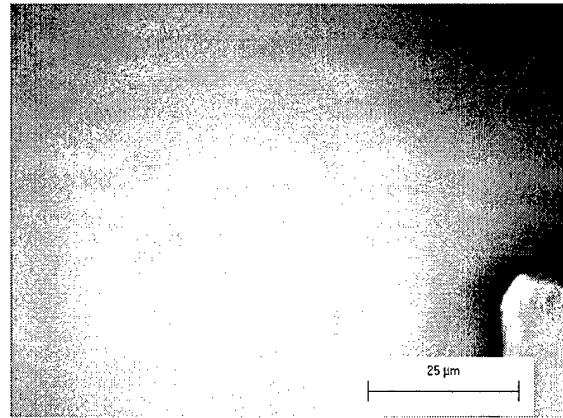

Wafer 6 – Trench 4 at 1000x magnification  
– post 2-hour polish, pressure = 5 lb/in<sup>2</sup>,  
rpm = 120 condition

Appendix N: Wafer 6 – 150rpm Study at 5lb/in<sup>2</sup>

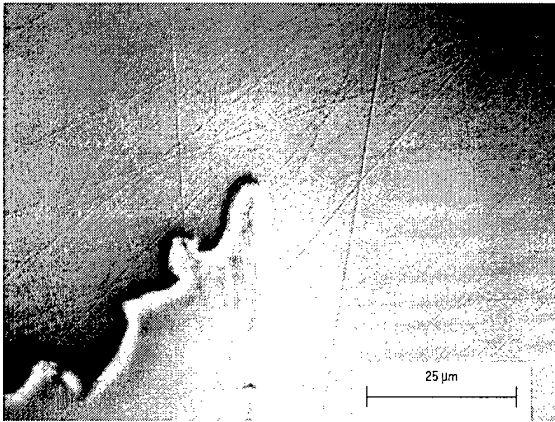

Wafer 6 – Trench 3 at 1000x magnification  
– pre- polish, pressure = 5 lb/in<sup>2</sup>,  
rpm = 150 condition

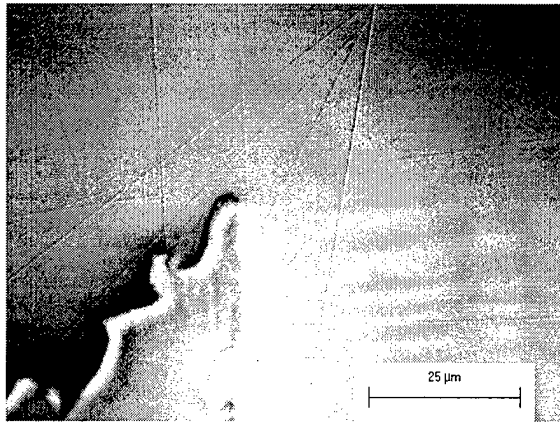

Wafer 6 – Trench 3 at 1000x magnification  
– post 30 minute polish, pressure = 5 lb/in<sup>2</sup>,  
rpm = 150 condition

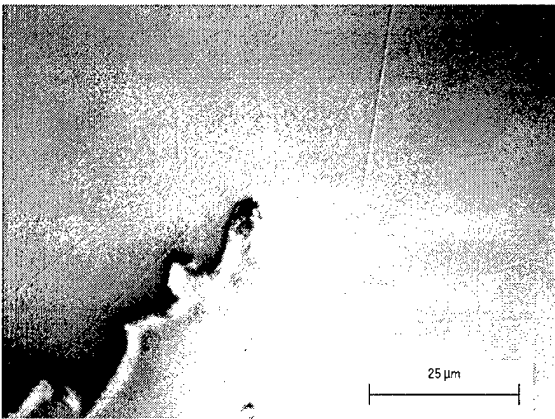

Wafer 6 – Trench 3 at 1000x magnification  
– post 60 minute polish, pressure = 5 lb/in<sup>2</sup>,  
rpm = 150 condition

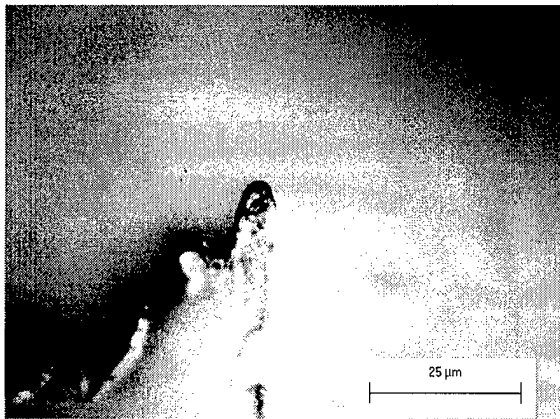

Wafer 6 – Trench 3 at 1000x magnification  
– post 90 minute polish, pressure = 5 lb/in<sup>2</sup>,  
rpm = 150 condition

**Appendix O: Wafer 6 – Initial 180rpm Study at 5lb/in<sup>2</sup>**

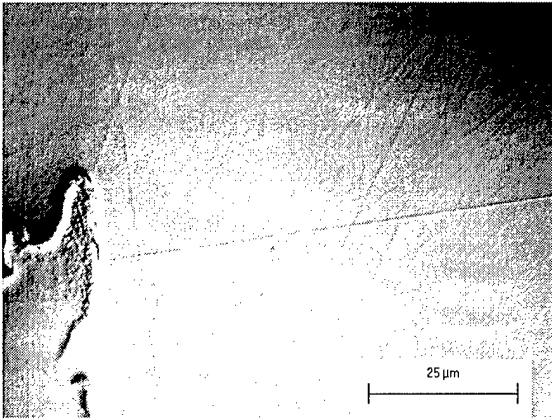

Wafer 6 – Trench 3 at 1000x magnification  
– pre- polish, pressure = 5 lb/in<sup>2</sup>,  
rpm = 180 condition

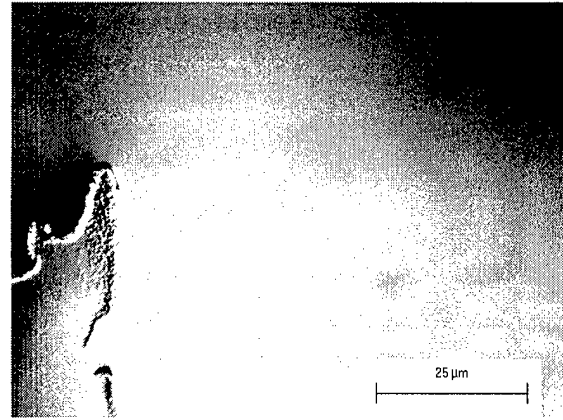

Wafer 6 – Trench 3 at 1000x magnification  
– post 30 minute polish, pressure = 5 lb/in<sup>2</sup>,  
rpm = 180 condition

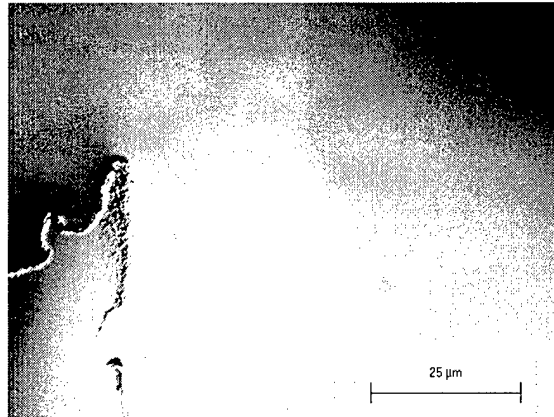

Wafer 6 – Trench 3 at 1000x magnification  
– post 60 minute polish, pressure = 5 lb/in<sup>2</sup>,  
rpm = 180 condition

**Appendix P: Wafer 6 – Final 180rpm Study at 5lb/in<sup>2</sup>**

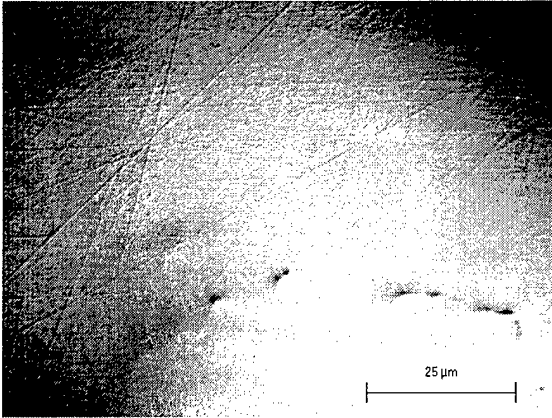

Wafer 5 – Trench 4 at 1000x magnification  
– pre- polish, pressure = 5 lb/in<sup>2</sup>,  
rpm = 180 condition

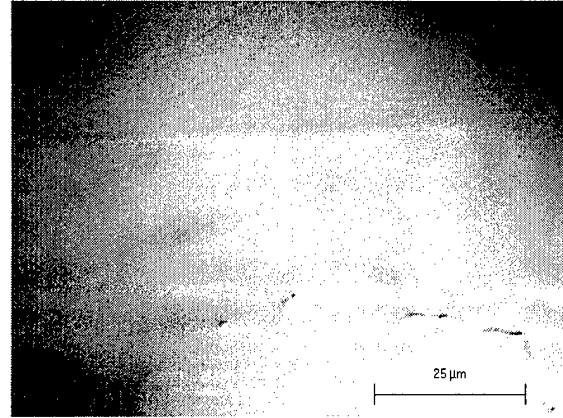

Wafer 5 – Trench 4 at 1000x magnification  
– post 30 minute polish, pressure = 5 lb/in<sup>2</sup>,  
rpm = 180 condition

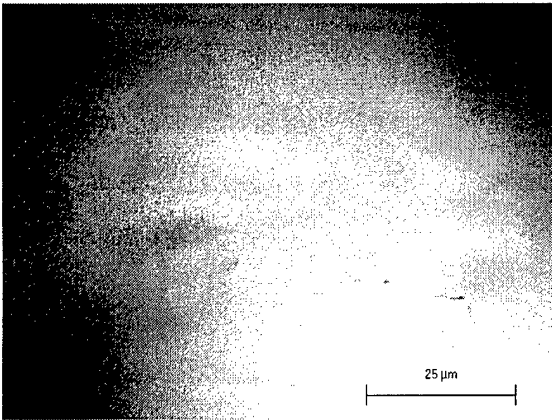

Wafer 5 – Trench 4 at 1000x magnification  
– post 60 minute polish, pressure = 5 lb/in<sup>2</sup>,  
rpm = 180 condition

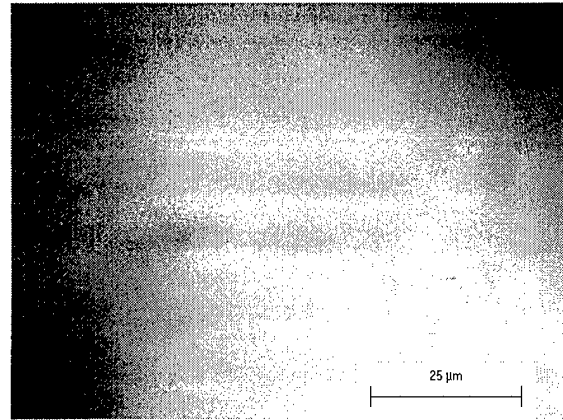

Wafer 5 – Trench 4 at 1000x magnification  
– post 90 minute polish, pressure = 5 lb/in<sup>2</sup>,  
rpm = 180 condition

## Bibliography

- Harris, Gary L. Properties of Silicon Carbide. London: INSPEC, the Institution of Electrical Engineers, 1995.
- Kikuchi, Masao, Yutaka Takahashi, Tadatomo Suga, Shigenobu Suzuki, and Yoshio Bando. "Mechanochemical Polishing of Silicon Carbide Single Crystal with Chromium(III) Oxide Abrasive," Journal of the American Ceramic Society, 75(1): 189-194 (1 January 1992).
- Levert, Joseph A., Francis M. Mess, Richard F. Salant, Steven Danyluk, and A. Richard Baker. "Mechanisms of Chemical-Mechanical Polishing of SiO<sub>2</sub> Dielectric on Integrated Circuits," Tribology Transactions, 41: 593-599 (1998).
- Li, Weidan, Dong Wook Shin, Minoru Tomozawa, Shyam P. Murarka. "The Effect of the Polishing Pad Treatments on the Chemical-Mechanical Polishing of SiO<sub>2</sub> Films," Thin Solid Films, 270: 601-606 (1995).
- Neudeck, Phil. "Silicon Carbide High Temperature Integrated Electronics and Sensors," NASA Glenn Research Center Silicon Carbide Web Page, <http://www.lerc.nasa.gov/WWW/SiC/SiC.html>.
- Owman, Fredrik, C. Hallin, Per Martensson, and E. Janzen. "Removal of polishing-induced damage from 6H-SiC(0001) substrates by hydrogen etching," Journal of Crystal Growth, 167: 391-395 (1996).
- Palmour, J. W. and R. F. Davis. "Dry etching of  $\beta$ -SiC in CF<sub>4</sub> and CF<sub>4</sub> + O<sub>2</sub> mixtures," Journal of Vacuum Science Technology A, 4 (3): 590-593 (May/June 1986).
- Pietsch, G. J., G. S. Higashi, and Y. J. Chabal. "Chemomechanical polishing of silicon: Surface termination and mechanism of removal," Applied Physics Letters, 64 (23): 3115-3117 (6 June 1994).
- Pietsch, G. J., Y. J. Chabal, and G. S. Higashi. "Infrared-absorption spectroscopy of Si(100) and Si(111) surfaces after chemomechanical polishing," Journal of Applied Physics, 78 (3): 1650-1658 (1 August 1995).
- Port, Otis. "A New Non-Wrinkle in Chipmaking," Business Week: 82(30 September 1996).
- Ragone, David V. Thermodynamics of Materials Volume II. New York: John Wiley & Sons, Incorporated, 1995.



- Sugiura, J., W. J. Lu, K. C. Cadien, and A. J. Steckl. "Reactive ion etching of SiC thin films using fluorinated gases," Journal of Vacuum Science Technology B, 4(1): 349-353 (January/February 1986).
- Sze, S. M., Semiconductor Devices: Physics and Technology. New York: John Wiley & Sons, 1985.
- Tichy, John, Joseph A. Levert, Lei Shan, and Steven Danyluk. "Contact Mechanics and Lubrication Hydrodynamics of Chemical Mechanical Polishing," Journal of the Electrochemical Society, 146(4): 1523-1528 (1999).
- Trogolo, J. A. and K. Rajan. "Near surface Modification of Silica Structure induced by chemical/mechanical polishing," Journal of Materials Science, 29: 4554-4558 (1994).
- Tseng, Wei-Tsu and Ying-Lang Wang. "Re-examination of Pressure and Speed Dependences of Removal Rate during Chemical-Mechanical Polishing Processes," Journal of the Electrochemical Society, 144(2): L15-L17 (February 1997).
- Tseng, Wei-Tsu, Jyh-Hwa Chin, and Lee-Chieh Kang. "A Comparative Study on the Roles of Velocity in the Material Removal Rate during chemical Mechanical Polishing," Journal of the Electrochemical Society, 146(5): 1952-1959 (1999).
- Yassen, A. Azzam, Christian A. Zorman, and Mehran Mehregany. "Roughness Reduction of 3C-SiC Surfaces Using SiC-Based Mechanical Polishing Slurries," Journal of the Electrochemical Society, 146(1): 327-330 (1999).
- Zhou, Ling, Valerie Audurier, and Pirouz Pirouz. "Chemomechanical Polishing of Silicon Carbide," Journal of the Electrochemical Society, 144(6): L161-L163 (June 1997).
- Zhu, Zhize, Viktor Muratov, and Traugott E. Fischer. "Tribochemical polishing of silicon carbide in oxidant solution," Wear: an International Journal on the Science and Technology of Friction, Lubrication and Wear, 225/229: 848-856 (1 April 1999).

REPORT DOCUMENTATION PAGE			Form Approved OMB No. 074-0188	
Public reporting burden for this collection of information is estimated to average 1 hour per response, including the time for reviewing instructions, searching existing data sources, gathering and maintaining the data needed, and completing and reviewing the collection of information. Send comments regarding this burden estimate or any other aspect of the collection of information, including suggestions for reducing this burden to Washington Headquarters Services, Directorate for Information Operations and Reports, 1215 Jefferson Davis Highway, Suite 1204, Arlington, VA 22202-4302, and to the Office of Management and Budget, Paperwork Reduction Project (0704-0188), Washington, DC 20503				
1. AGENCY USE ONLY (Leave blank)		2. REPORT DATE March 2000	3. REPORT TYPE AND DATES COVERED Master's Thesis	
4. TITLE AND SUBTITLE  Chemical Mechanical Polishing Optimization for 4H-SiC			5. FUNDING NUMBERS	
6. AUTHOR(S)  Craig L. Neslen, Captain, USAF				
7. PERFORMING ORGANIZATION NAMES(S) AND ADDRESS(S)  Air Force Institute of Technology Graduate School of Engineering and Management (AFIT/EN) 2950 P Street, Building 640 WPAFB OH 45433-7765			8. PERFORMING ORGANIZATION REPORT NUMBER  AFIT/GMS/ENP/00M-02	
9. SPONSORING / MONITORING AGENCY NAME(S) AND ADDRESS(ES) AFRM/MLPO Attn: William C. Mitchel 2977 P Street, Ste. #1 WPAFB OH 45433-7765			10. SPONSORING / MONITORING AGENCY REPORT NUMBER  DSN: 785-4474 ext. 3252	
11. SUPPLEMENTARY NOTES  Dr. Robert L. Hengehold, ENP, DSN: 785-3636 ext. 4502				
12a. DISTRIBUTION / AVAILABILITY STATEMENT  APPROVED FOR PUBLIC RELEASE; DISTRIBUTION UNLIMITED.			12b. DISTRIBUTION CODE	
<b>ABSTRACT (Maximum 200 Words)</b>  Chemical mechanical polishing (CMP) studies of 1 3/8" 4H-SiC wafers were performed in an attempt to identify the polishing parameter values that result in a maximum material removal rate. Previous studies reported increased material removal rates associated with increasing polishing temperature, slurry pH, pressure, and polishing pad speed. The effects of temperature, slurry pH, polishing pressure, and polishing pad speed were examined independently while keeping other polishing parameters constant. Material removal rates were determined using pre and post-polish wafer mass measurements. Photographs at specific wafer locations were obtained before and after each polishing period and compared to calculated removal rates.  Studies indicated that increasing temperatures affect the pad fibers and do not significantly increase the chemical reaction rate between the polishing slurry and wafer surface atoms. Also, in contradiction to other studies, a decrease in material removal was observed for increasing slurry pH levels. Increased applied pressure resulted in higher removal rates and unwanted polishing pad damage. Higher pad rotational speeds produced non-linear increases in material removal rates and appeared to have the greatest impact on material removal rates.				
14. SUBJECT TERMS Polishing, Semiconductor Polishing, Chemical Mechanical Polishing, Chemomechanical Polishing, Substrate, Substrate Preparation, Silicon Carbide, 4H-SiC			15. NUMBER OF PAGES 107	
			16. PRICE CODE	
17. SECURITY CLASSIFICATION OF REPORT UNCLASSIFIED	18. SECURITY CLASSIFICATION OF THIS PAGE UNCLASSIFIED	19. SECURITY CLASSIFICATION OF ABSTRACT UNCLASSIFIED	20. LIMITATION OF ABSTRACT UL	