

Air Force Institute of Technology

AFIT Scholar

Theses and Dissertations

Student Graduate Works

3-2003

Instilling an Entrepreneurial Mindset in Department of Defense (DoD) Organizations: Evidence from Entrepreneurial Organizations in the Private Sector

Rochelle D. Smith

Follow this and additional works at: <https://scholar.afit.edu/etd>



Part of the [Entrepreneurial and Small Business Operations Commons](#)

Recommended Citation

Smith, Rochelle D., "Instilling an Entrepreneurial Mindset in Department of Defense (DoD) Organizations: Evidence from Entrepreneurial Organizations in the Private Sector" (2003). *Theses and Dissertations*. 4178.

<https://scholar.afit.edu/etd/4178>

This Thesis is brought to you for free and open access by the Student Graduate Works at AFIT Scholar. It has been accepted for inclusion in Theses and Dissertations by an authorized administrator of AFIT Scholar. For more information, please contact richard.mansfield@afit.edu.



**INSTILLING AN ENTREPRENEURIAL MINDSET IN DEPARTMENT OF
DEFENSE (DoD) ORGANIZATIONS: EVIDENCE FROM ENTREPRENEURIAL
ORGANIZATIONS IN THE PRIVATE SECTOR**

THESIS

Rochelle D. Smith, 2nd Lieutenant, USAF

AFIT/GAQ/ENV/03-07

**DEPARTMENT OF THE AIR FORCE
AIR UNIVERSITY**

AIR FORCE INSTITUTE OF TECHNOLOGY

Wright-Patterson Air Force Base, Ohio

APPROVED FOR PUBLIC RELEASE; DISTRIBUTION UNLIMITED.

The views expressed in this thesis are those of the author and do not reflect the official policy or position of the United States Air Force, Department of Defense, or the U.S. Government.

AFIT/GAQ/ENV/03-07

INSTILLING AN ENTREPRENEURIAL MINDSET IN
DEPARTMENT OF DEFENSE (DoD) ORGANIZATIONS: EVIDENCE FROM
ENTREPRENEURIAL ORGANIZATIONS IN THE PRIVATE SECTOR

THESIS

Presented to the Faculty
Department of Systems Engineering and Management
Graduate School of Engineering and Management
Air Force Institute of Technology
Air University
Air Education and Training Command
In Partial Fulfillment of the Requirements for the
Degree of Master of Science in Acquisition Management

Rochelle D. Smith, BA.

2nd Lieutenant, USAF

March 2003

INSTILLING AN ENTREPRENEURIAL MINDSET IN
DEPARTMENT OF DEFENSE (DoD) ORGANIZATIONS: EVIDENCE FROM
ENTREPRENEURIAL ORGANIZATIONS IN THE PRIVATE SECTOR

Rochelle D. Smith, BA.
2nd Lieutenant, USAF

Approved:

/signed/	6 Mar 03
_____ Timothy S. Reed, Maj, USAF (Chairman)	_____ Date

/signed/	6 Mar 03
_____ Daniel T. Holt, Maj, USAF (Member)	_____ Date

/signed/	21 Feb 03
_____ Michael T. Rehg, Maj, USAF (Member)	_____ Date

Acknowledgements

First and foremost I would like to thank Major Tim Reed for his patience, entrepreneurial expertise and editing skill. To my thesis committee, Major Danny Holt and Major Michael Rehg, thank you for helping me to navigate the sometimes stormy thesis waters. Special thanks to Professor Rita McGrath and Professor Gideon Markman for their generous contributions towards my thesis effort. To my classmates and AFIT peers, many thanks for your support and humor. I would not have made it this far without the laughter you shared so freely, especially in the late hours of the night as we labored in the AFIT computer labs. And finally to my family, you kept me motivated when the last thing I wanted to do was work. Thank you for believing in me.

I would also like to thank all of the strategic leaders from the various private firms who participated in this study. Thank you for taking the time out of your busy schedules to talk to me and share your firm's entrepreneurial experiences. Without your assistance my thesis effort would not have been successful.

Rochelle D. Smith

Table of Contents

	Page
Acknowledgements.....	iv
List of Figures.....	ix
List of Tables.....	x
Abstract.....	xi
I. Introduction.....	1
Literature Review.....	2
Problem Statement.....	3
Research Question.....	4
Methodology.....	4
Results.....	5
Analysis.....	6
II. Literature Review.....	7
Chapter Overview.....	7
The Entrepreneurial Mindset.....	7
Brief History of Entrepreneurship.....	9
Entrepreneurial Orientation.....	10
Corporate Entrepreneurship.....	11
Renewal Corporate Entrepreneurship.....	12
Going Beyond Start-ups: Intrapreneurship.....	13
Importance of This Research.....	15
Firm Selection Criteria.....	17
Firm's Expressed Desire to Pursue an Entrepreneurial Mindset.....	18
Firm's Position.....	19
Rate of Innovation.....	20
Number of Employees.....	20
Organization Size.....	21
Number of Operating Locations.....	22
Company Age.....	22
Organizational Characteristics.....	23
Antecedents.....	25
Barriers Encountered.....	27
Outcomes.....	29
Acadia Inc.....	30

	Page
Entrepreneurship in Government.....	31
Chapter Summary	32
III. Methodology	33
Chapter Overview.....	33
Research Objectives.....	33
Research Design	33
Methodology.....	34
Data Collection	36
Sample.....	36
Interview Questions.....	38
Reliability	39
Validity	40
Chapter Summary	41
IV. Results.....	42
Chapter Overview.....	42
Background on Firms	42
3M.....	43
AT&T.....	43
Canon	44
Dow.....	44
Duke/Fluor Daniel	44
GE Capital.....	45
Intel	45
Kone.....	45
Mobil.....	46
NCR	46
Shell	47
Xerox.....	47
Qualitative Survey Questions	48
Qualitative Responses to Q21.....	50
Patterns that Emerged:	50
Qualitative Responses to Q22.....	52
Patterns that Emerged:	52
Qualitative Responses to Q23.....	54
Patterns that Emerged:	54
Qualitative Responses to Q24.....	56
Patterns that Emerged:	56
Qualitative Responses to Q25.....	57
Patterns that Emerged:	57

	Page
Quantitative Results.....	58
Means: Highs and Lows.....	58
Patterns that Emerged:	59
Chapter Summary	61
V. Analysis.....	62
Chapter Overview	62
Analysis	62
Initiators	63
Organizational Practices	64
Barriers.....	65
Outcomes	67
Discussion of Results.....	68
Limitations	70
Research Questions & Problem Statement	73
Recommendations.....	75
Appendix A: 3M Interview Transcript	77
Appendix B: AT&T Interview Transcript	82
Appendix C: Canon Interview Transcript.....	88
Appendix D: Dow Interview Transcript	97
Appendix E: Duke/Fluor Daniel Interview Transcript	101
Appendix F: GE Capital Interview Transcript.....	108
Appendix G: Intel Interview Transcript.....	114
Appendix H: Kone Interview Transcript	126
Appendix I: Mobil Interview Transcript.....	135
Appendix J: NCR Interview Transcript	142
Appendix K: Shell Interview Transcript.....	144

	Page
Appendix L: Xerox Interview Transcript	153
Appendix M: Numerical Assessment Responses (Part 1)	159
Appendix N: Numerical Assessment Responses (Part 2)	160
Appendix O: Numerical Assessment Responses (Part 3)	161
Appendix P: Numeric Assessment Questionnaire	162
Appendix Q: Notes Developed During the Pattern Matching Process	167
Response 1	167
<i>Themes that Came Up More than Once</i>	167
<i>Themes that Only One Firm Mentioned</i>	167
Response 2	167
<i>Themes that Came Up More than Once</i>	167
<i>Themes that Only One Firm Mentioned</i>	167
Response 3	168
<i>Themes that Came Up More than Once</i>	168
<i>Themes that Only One Firm Mentioned</i>	168
Response 4	169
<i>Themes that Came Up More than Once</i>	169
<i>Themes that Only One Firm Mentioned</i>	169
Response 5	170
<i>Themes that Came Up More than Once</i>	170
<i>Themes that Only One Firm Mentioned</i>	170
Appendix R: Additional Questions Asked During Telephone Interviews	171
Appendix S: Note Regarding the Joint Nature of Data Collection	173
Bibliography	174
Vita	182

List of Figures

Figure	Page
1. Integrated Model of the Corporate Entrepreneurial Concept.....	61

List of Tables

Table	Page
1. Firm Selection Criteria.....	23
2. Open-Ended Interview Questions.....	47

Abstract

Calls for transforming government and creating entrepreneurial cultures in non-profit motivated organizations are everywhere today. The primary method proposed for instilling an entrepreneurial mindset is to institute “best practices” or “lessons learned” from commercial firms that have characteristics similar to those of large government organizations. While the similarities between the private and public sector organizations are many, the differences (e.g. legal restrictions, missions, and motivation of members of the organization) are also notable. This exploratory study seeks to more clearly define the commonalities between the experiences of private sector firms and how those experiences can be captured to help DoD organizations to transform themselves to better execute their mission. The gathered data is analyzed for potential antecedents for, barriers to, and outcomes of the implementation of an entrepreneurial mindset in large, global, highly structured commercial firms that have instituted an entrepreneurial culture. It then analyzes the findings to determine the potential applicability of the guidance for actual implementation in government organizations.

INSTILLING AN ENTREPRENEURIAL MINDSET IN DEPARTMENT OF
DEFENSE (DoD) ORGANIZATIONS: EVIDENCE FROM ENTREPRENEURIAL
ORGANIZATIONS IN THE PRIVATE SECTOR

I. Introduction

The United States military is always trying to stay competitive. The competition continues to change, requiring DoD to compete in different ways than they have been required to in the past. Secretary of Defense Donald Rumsfeld made this clear in his article depicting how even now in an age of vast technology U.S. soldiers still have had to form a cavalry to accomplish their mission in Afghanistan (Rumsfeld, 2002). Successfully meeting the challenges presented by these new competitors requires the use of an entrepreneurial renewal mindset. The use of low technology methods to solve problems is evidence that even today the entrepreneurial mindset does not always have to involve new technology. Sometimes it can be about reapplying old ideas in new ways.

Just as firms are using the entrepreneurial mindset to compete with their private sector counterparts, so too can we as DoD organizations use it to better prepare for our adversaries worldwide. Formalizing the organization's approach to implementing the entrepreneurial mindset is a relatively new endeavor for DoD organizations. Due to this relatively new approach for DoD organizations, they must look to their more seasoned private sector counterpart organizations in order to assess what potential benefits can be gained for DoD organizations and their customers by correctly implementing the entrepreneurial mindset.

In this research, I analyze the experiences of private sector firms to determine if emerging patterns from successful entrepreneurial activities in the private sector might provide guidance for public sector organizations, such as DoD.

DoD is not a profit focused organization, yet many of the issues that arise as private sector organizations attempt to be more innovative and/or efficient apply to DoD as well. If DoD can position itself in such a way as to be able to create and implement new products and services in a more timely manner, a variety of customers within DoD may benefit. This research endeavor seeks to identify patterns in successful private sector firms and assess their applicability to entrepreneurial activities in public sector organizations. The remainder of this chapter provides an overview of each of the chapters presented in this thesis.

Literature Review

Interest in fields relating to the entrepreneurial mindset has been increasing in both the public and private sectors. McGrath and MacMillan (2000) define entrepreneurial mindset using five characteristics that “habitual entrepreneurs” have in common. These characteristics include: passionately seeking new opportunities, pursuing opportunities with a large degree of discipline, limiting the number of opportunities they pursue during a given time, focusing on adaptive execution, and incorporating people inside and outside of the organization in their quest to achieve successful implementation. While this definition applies to individual entrepreneurs, it can also be employed when examining individual firms in the private sector and attempting to identify the characteristics that have allowed them to use the entrepreneurial mindset to advance the firm’s position. Some potential ways to identify

firms' disciplined pursuit of opportunities include comparing vision statements, culture, decision-making processes, and percentage of revenue increase after implementation of entrepreneurial mindset.

For many, entrepreneurship is the future. Yet today there are many obstacles in defining exactly what entrepreneurship encompasses. As the extant research indicates, entrepreneurship has a vast number of benefits for those individuals and organizations that incorporate its principles correctly. Once there is an accepted definition which rigorously defines the phenomenon of entrepreneurship, both scholars and practitioners will be able to implement entrepreneurship systematically in their own lives and businesses. The potential benefits of properly implementing entrepreneurship can be substantial both for private industry and for organizations within the DoD.

Problem Statement

DoD organizations have been attempting to transform so that the end customer (i.e. the war fighter) gets what they need before they need it. Due to the nature of war, we spend most of our time in preparation for the unknown. While many private sector firms may voice a similar concern about the products they produce few organizations are tasked with a more unique mission than the military. The problem is how to transform a large slow moving bureaucratic organization into a sleek, responsive organization that can produce products for war fighters who may need those products at a moments notice at any location imaginable from the mountains of Afghanistan to the peninsula of North Korea.

Research Questions

I seek to identify patterns in similarities between successful entrepreneurial activities in the private sector that public sector organizations, such as DoD, may use in the future. Specifically, how do we identify what entrepreneurial success is in a way that is meaningful to public sector organizations such as DoD? Further, how can those processes required to attain entrepreneurial success be applied to public sector organizations, such as DoD?

Methodology

This thesis effort was conducted using a combination of qualitative surveys and secondary archival data. Twelve commercial firms that have initiated entrepreneurial practices composed the basis of the research. The study uses case study analysis techniques to analyze the data gathered. Employing these techniques, the study outlines specific characteristics for successful implementation of the entrepreneurial mindset at a firm level, as well as particular tactics used for overcoming barriers to implementation of entrepreneurial ideas, these characteristics are then used to determine if organizations within DoD can follow a similar pattern as the organization strives to become more innovative.

Secondary archival data were used to identify 30 firms that have been successful with the implementation of the entrepreneurial mindset. Based on the preliminary research effort the following characteristics have been identified as potential parameters for selecting private sector firms to analyze further; (1) the formally expressed desire by the firm to pursue the entrepreneurial mindset in their firm's business processes or products, (2) firm's position in their industry, (3) rate of innovation since adopting the

entrepreneurial mindset, (4) number of employees, (5) size of the organization, (6) number of operating locations, and (7) age of the company. Each of these seven criteria was used to identify only those firms who are as comparable to DoD as possible.

The firms were initially contacted to if their Chief Information Officer (CIO), supervisor of training and the supervisor of operations were willing to be interviewed about the experiences their firms had when implementing the entrepreneurial mindset. Of the initial 30 firms 12 were selected for the final interview process. The case study approach, as outlined by Yin (1994), was utilized to assess the reliability and validity of the qualitative and quantitative data gathered as well as to assist in the creation of the survey instrument.

Results

The results of the qualitative and quantitative surveys are outlined. Brief backgrounds are given for each of the twelve firms interviewed to help better understand the responses garnered from each firm. A list of the qualitative questions was developed as well as a complete record of the quantitative questions. Based on the case study findings, a model was developed to explain the results. For the qualitative results patterns that emerged for each question are briefly explained with examples where applicable from individual firms. Highlights of the qualitative data are explained including an explanation of the highest and lowest scores. Questions that had notable responses are incorporated into this chapter in addition to noting responses from some of the firms that differed from the opinions expressed by strategic leaders from the other firms.

Analysis

An explanation of the results gathered is outlined in the final chapter. This section includes a discussion of the limitations of the research as well as recommendations for future research. Some of the limitations include only interviewing one strategic leader from a large firm instead of a variety of people to get a better feeling for the complexity of the entrepreneurial activity taking place within the organization. A thorough review of the extant literature revealed a lack of research on public or not-for-profit organizations such as those within DoD. Because of the daunting size of this research gap, this research endeavor was only able to begin to investigate the processes that large organizations in the private sector have utilized to implement an entrepreneurial mindset. In the future it is recommended that more research be done on which DoD organizations will be the best candidates for implementing the entrepreneurial mindset and in which the greatest impact will be realized for the most important human resource, the war fighter.

II. Literature Review

Chapter Overview

This chapter serves as an overview of the existing entrepreneurial research. It begins with a definition of the entrepreneurial mindset followed by a brief history of the research on this topic, and more specific types of entrepreneurial research, which have emerged over time. Four specific types of entrepreneurship are detailed; entrepreneurial orientation, corporate entrepreneurship, renewal corporate entrepreneurship and intrapreneurship. The relevance of this research is outlined preceded by an explanation of the seven criteria used to select the private sector firms which were assessed for the research endeavor. After discussing selection criteria three key organizational characteristics are explained as they relate to the implementation of the entrepreneurship. A real world example from Acordia Inc. is outlined to exemplify how the organizational characteristics mentioned above can relate to implementation. This chapter concludes with an explanation of the gap in the entrepreneurial research when it comes to applying the entrepreneurial mindset to DoD organizations.

The Entrepreneurial Mindset

According to McGrath and MacMillan (2000:2-4) the entrepreneurial mindset can be defined using five characteristics that “habitual entrepreneurs” have in common. These characteristics include: passionately seeking new opportunities, pursuing opportunities with a large degree of discipline, limiting the number of opportunities they pursue during a given time, focusing on adaptive execution, and incorporating people inside and outside of the organization in their quest to achieve successful implementation.

While this definition is focused specifically on individual entrepreneurs, it can also be employed when examining individual firms in the private sector and attempting to identify the characteristics that have allowed them to use the entrepreneurial mindset to advance the firm's position. There is a wealth of diversity when it comes to defining entrepreneurship or the entrepreneurial mindset (Fiore & Lussier, 2002).

Although many of these definitions have merit, McGrath and MacMillian (2000) have the most relevance for this research effort. A brief overview of how difficult the entrepreneurial mindset has been to define as well as an example of other definitions follows with further explanation as to why the McGrath and MacMillian (2000) definition was found to be superior for this research endeavor.

The entrepreneurial mindset is arguably the driving force behind defining the way all successful business will be conducted in the future, both in the private and the public sector. Yet today we face many obstacles in defining exactly what that entrepreneurial mindset encompasses (Cooper & Markman, 2000; Low & MacMillan, 1988). Lumpkin and Dess (1996), allude to the difficulty of not having a clearly understood definition of entrepreneurship or the entrepreneurial mindset when they state,

“...[while] efforts have served to point out the various dimensions of the entrepreneurial process, they have not led to any widely held consensus regarding how to characterize entrepreneurship. This lack of consensus has impeded progress for researchers toward building and testing a broader theory of entrepreneurship, and has made it especially difficult for them to investigate the relationship of entrepreneurship to performance” (1996:135).

One of the main points of being entrepreneurial is to improve performance. If researchers cannot clearly relate the implementation of the entrepreneurial mindset to improved performance there is little reason to expect private or public organizations to attempt to be more entrepreneurial. Without a clear definition it is almost impossible to

replicate that entrepreneurial spirit for the benefit of both novice and seasoned entrepreneurs (Fiore & Lussier, 2002; Tuggle, 2002; Shane, 2000).

Stevenson (2002:12) explains that,

“The *caveat* must be given; however, that entrepreneurship is more than the sum of its parts. Successful entrepreneurship is a study of the dynamic fit between a set of individuals, as opportunity derived from a particular context, and the deal that unites them. The nature of the fit requires constant vigilance. There is no such thing as an opportunity forever...the best deals are subject to strategic behavior when their consequences are fully understood...The assumption that rational, evaluating maximizing individuals start businesses cannot begin to account fully for the instances of creative genius, self-sacrificing loyalty, and charismatic leadership.”

As can be gleaned from the preceding paragraphs, the entrepreneurial mindset can be a challenging concept to define. McGrath and MacMillian (2000:2-4) have met this challenge with a dynamic yet concise definition. The five characteristics that “habitual entrepreneurs” have in common are those same characteristics it would behoove DoD organizations to employ.

Brief History of Entrepreneurship

While the practice of entrepreneurship in the form of new venture creation has occurred throughout history, once the benefits of adopting the entrepreneurial mindset became evident, secular literature on the subject proliferated (Cooper, Markman & Niss, 2000). Originally, research on entrepreneurship focused primarily on small business (Cooper & Weil, 2002). Small businesses could be considered entrepreneurial with only one motivated entrepreneur in their midst to direct.

Harvard is reported to have offered the first classes on the subject in the late 1940s (Cooper & Weil, 2002). Over the last few decades, conferences and papers on entrepreneurship became resolutely more commonplace (Cooper & Wiel, 2002). As the

concept gained wider acceptance, the term “entrepreneurship” began to be applied not just to small businesses but to large businesses as well (Chandler & Lyon, 2001:1). As this literature review indicates the concept of entrepreneurship is important to both researchers and practitioners.

Entrepreneurial Orientation

Covin and Slevin (1989) are credited with developing the most commonly referenced “operationalization of EO [entrepreneurial orientation] in both the entrepreneurship and strategic management literature” (Kreiser, Marino & Weaver, 2002:). Covin and Slevin (1989:79) said that there are 3 parts of entrepreneurial orientation; innovation, proactiveness and risk taking and that these three areas need to be assessed simultaneously to fully understand the “strategic orientation” as it relates to entrepreneurship (Covin & Slevin, 1989:79). Each of these parts has been mentioned in other areas of entrepreneurship research but tying them all together allows for a more rigorous and directed theory.

One of the ways the theory of entrepreneurial orientation has been furthered is by comparing the modes entrepreneurship takes in the U.S. versus in other countries. Lee and Peterson (2000:401) propose, “that only those countries with specific cultural tendencies will engender a strong entrepreneurial orientation, hence experiencing more entrepreneurship and global competitiveness.”

As we move to an increasingly global environment, economically, if the ability to be entrepreneurial is significantly effected by where the entrepreneurship is more likely to flourish that is important to know, especially for multi-international firms. Similar to the DoD organizations which have many locations throughout the world private multi-

international organizations may want to be entrepreneurial but according to many entrepreneurial orientation scholars (Lee & Peterson, 2000; Lumpkin & Dess, 1996) these firms may need to address cultural concerns first. Lumpkin and Dess (1996:135) state that, “the relationship between EO & performance is context specific and...the dimensions of EO may vary independently of each other in given context.” Being aware of the complexity of the entrepreneurial orientation can benefit each of us as we attempt to benefit by making our own organizations more entrepreneurial.

Corporate Entrepreneurship

As discussed earlier in this chapter, entrepreneurship includes a number of characteristics. Kuratko, Ireland and Hornsby (2001:60) reiterate many of these characteristics when they state that, “Entrepreneurship includes acts of creation, renewal, or innovation that occur within or outside an organization. When these acts take place in an established firm, particularly a large one... they describe corporate entrepreneurship.” Furthering the definition of this type of entrepreneurship Sharma and Chrisman (1999:21) state that, “Corporate entrepreneurship is the process whereby an individual or a group of individuals, in association with an existing organization, create a new organization or instigate renewal or innovation within that organization.”

When the entrepreneurial mindset has been properly applied to large organizations it has often lead to tremendous success. Jack Welch, CEO of General Electric used the entrepreneurial mindset to propel his company forward from a desirable business position to even enviable position not only in its industry but in the global business landscape as well (Hitt & Reed, 2000). In GE’s case, the entrepreneurial mindset helped the firm to reassess the direction it was going and follow a more proactive

plan for the future (Hitt & Reed, 2000). “Corporate entrepreneurship can enhance shareholder value by creating a work environment that supports individual and corporate growth, giving employees an opportunity to use their creative skills, quickening a company’s response to the market, and creating an organizational culture that fosters cross-functional collaboration” (Tuggle, 2002:6).

Many large companies are finding that implementation of corporate entrepreneurship strategies has become mandatory for the companies’ survival. Most entrepreneurial scholars agree that properly applied entrepreneurial tactics can improve the firm’s chance of success in the following ways: helping the firm to gain new capabilities (Zahra, Neubaum & Huse, 2000), improving the firm’s performance (Lumpkin & Dess, 1996), enhancing profitability (Covin & Slevin, 1991), and growth (Zahra, 1993). No one claims that the entrepreneurial mindset can fix every problem a company might potentially have, but in case after case applying the entrepreneurial mindset has offered companies both tangible and intangible benefits (Tuggle, 2002; McGrath & MacMillan, 2000; Hamel, 1999; Lumpkin & Dess, 1996; Slevin & Covin, 1990).

Renewal Corporate Entrepreneurship

With this definition in mind, Tuggle (2002:5) describes renewal corporate entrepreneurship in the following way, “Renewal [corporate entrepreneurship] is also used to describe an organization that seeks to sustain or improve its competitive standing by altering its internal processes, structures, and/or capabilities.” Similar to entrepreneurship in general, the specific goal of renewal corporate entrepreneurship is to make money for the company (Tuggle, 2002).

To relate renewal corporate entrepreneurship to the DoD, we want to create DoD organizations that are more responsive to war fighter needs in ever changing peacetime and wartime environments. Following this same theme Defense Secretary Donald Rumsfeld states that,

We must transform not only our armed forces but also the Defense Department that serves them—by encouraging a culture of creativity and intelligent risk-taking. We must promote a more entrepreneurial approach: one that encourages people to be proactive, not reactive, and to behave less like bureaucrats and more like venture capitalists; one that does not wait for threats to emerge and be “validated” but rather anticipates them before they appear and develops new capabilities to dissuade and deter them (Rumsfeld, 2002:29).

Rather than quickening the company’s response time to the market, we want to quicken the response time to the needs of the war fighter. While we are not a for-profit organization we are allotted limited resources through our congressionally approved budget process. Even though we are not making a profit there is understandable interest in finding ways to reduce our costs.

Going Beyond Start-ups: Intrapreneurship

While entrepreneurship is often associated with small firms and new venture startups, a growing body of literature indicates that large firms can also employ the entrepreneurial mindset. One way that some large firms approach being more entrepreneurial is by employing intrapreneurship. “In contrast to bureaucratic organizations, the entrepreneurial organization that sponsors entrepreneurship: focuses on results and teamwork, rewards innovation and risk-taking, tolerates and learns from mistakes, remains flexible and change-oriented” (Luchsinger & Bagby, 1987:12).

DoD organizations tend to be bureaucratic that is their nature, but that does not mean they cannot benefit from becoming more entrepreneurial. The list of entrepreneurial characteristics listed by Luchsinger & Bagby (1987) could be one of the most effective ways to help modernize DoD organizations.

Like entrepreneurship, intrapreneurship has a variety of meanings. For some, intrapreneurship means corporate-sponsored start-ups (Young, 1996). For others, intrapreneurship means an innovative mindset rather than a well defined process to be followed (Enbar, 1999). Adams (1995:31) cites intrapreneurship as a way to “capitalize on new business opportunities by taking advantage of in-house genius.” He notes that multinational firms like AT&T, Motorola and Xerox have reaped some of the potential benefits of intrapreneurship such as technological expertise and staff development (Adams, 1995).

Luchsinger and Bagby (1987) outlined some of the differences between intrapreneurs and entrepreneurs. They note that while the two terms are similar intrapreneurs tend to operate *within* an organization while entrepreneurs often have a more *independent* nature (Luchsinger & Bagby, 1987:12). Since DoD organizations such as the Air Force do not emphasize independence as much as teamwork, using Luchsinger and Bagby’s definition of both terms, intrapreneurship seems the more accurate term for the future efforts of DoD organizations.

Intrapreneurship is essential if large organizations such as DoD are to shift from traditional ways of doing things to using more entrepreneurial practices. Intrapreneurship must be an integral part of the framework of the approach in order to maximize the organization’s potential for success. Aldrich (2000:211) points out that there are a large

number of barriers to overcome when attempting to implement new processes into an organization. In this case what Aldrich (2000) refers to as the “population” can be seen to represent entrepreneurs when he states that, “Focusing on the early phases of a population’s life also reminds us that many promising populations never realize their potential, because they fail to develop an infrastructure, are unable to defeat or come to terms with opposing populations, and never win institutional support” (Aldrich, 2000: 211). This sort of resistance is exactly what the leaders of DoD organizations have to contend with as they attempt to try new processes to improve their organizations.

Importance of This Research

Entrepreneurship has proven its importance in a number of ways, but to many business people one of the most salient ways has been in the recent creation of new wealth. Hamel (1999) states that, “. . . in the new economy, investors don’t want stewards. They want entrepreneurial heroes-innovators who are obsessed with creating *new* wealth. Stewards conserve. Entrepreneurs create” (Hamel, 1999:71). For many people the association between being an entrepreneur and making money is a strong one. When corporate leaders look at the seemingly paltry payoff they receive from using traditional stewardship programs, such as supply chain management or enterprise resource planning, and compare that to what they could make using more innovative methods, they reassess the path their firm needs to be on to achieve a more successful future (Hamel, 1999).

Applying the entrepreneurial mindset to large companies instead of just focusing on small ones is not a new academic phenomenon. McGrath and MacMillian (2000), Hamel (1999), and Cringley (1996) all cite examples where the entrepreneurial mindset

has been applied to large organizations. In their book, McGrath and MacMillian (2000) detail the entrepreneurial efforts of a myriad of large companies including Oral B, 3M, AT&T and American Airlines. Rather than mention an exhaustive list of large companies that have implemented the entrepreneurial process, Hamel (1999:72-81) goes into great detail about the GameChanger process at Shell.

The GameChanger process was implemented to encourage entrepreneurial ideas to be heard and transformed into action from the bottom up (Hamel, 1999). This is particularly impressive considering the large size of Shell, since large firms are commonly perceived to be more set in their ways (Aldrich & Martinez, 2001; Damanpour, 1987). It can be relatively difficult for larger organizations to find ways to maintain a competitive edge. Shell's desire and ability to formalize a process that strives to maintain that edge is commendable. In Cringley's book (1996), he focuses on the entrepreneurial mindset in high technology companies, such as Microsoft and IBM. Here he details how these two large firms have approached entrepreneurship.

This thesis follows extant research in assuming that entrepreneurial thinking, when properly implemented, is beneficial to firms (Aldrich & Martinez 2001; Davidson, & Low 2001; Zahra, Jennings & Kuratko 1999). Entrepreneurship can be discussed in terms of new venture creation and/or how it pertains to making existing firms more flexible and innovative (Cooper, Markman, & Niss, 2000). For the purposes of this research the concern is not necessarily with venture creation but with *how* the entrepreneurial mindset is implemented to facilitate firms becoming more flexible and innovative. Cooper, Markman, and Niss (2000) clarify the relevance of entrepreneurship in today's world by saying,

“For public policy and strategy makers concerned with economic development, entrepreneurship offers promise as a source of job creation and innovation. For managers, entrepreneurial strategies suggest ways to revitalize existing organizations and make them more innovative. As entrepreneurship contributes to a more vital and innovative economy, the public can benefit from new jobs, services, and products that become available” (115-116).

With that in mind, the focus becomes finding ways to harness the benefits that private companies have experienced and applying them to organizations within the DoD.

It is important to note that while there are distinctions made between public and not-for-profit organizations in some academic literature, for the purpose of this thesis effort that distinction is ignored. The major distinction applicable for this research is private organizations versus any other types. Since DoD organizations are definitely not considered private, all organizations that are *not* private are seen to be comparable to DoD organizations for the purpose of this research. As more research becomes available outlining how entrepreneurship effects public and not-for-profit organizations differently the assumption of their similarity for this thesis can be revised to reflect that future maturity in the entrepreneurial research.

Firm Selection Criteria

The firms selected for this research effort were chosen using the following seven criteria: (1) the formally expressed desire by the firm to pursue the entrepreneurial mindset in their firm’s business processes or products, (2) firm’s position in their industry, (3) rate of innovation since adopting the entrepreneurial mindset, (4) number of employees, (5) size of the organization, (6) number of operating locations, and (7) age of the company. These preliminary criteria were selected to differentiate those private sector firms that would most closely resemble DoD organizations. As stated earlier, the

ultimate goal of this research is to be able to apply the findings to DoD organizations. Because the DoD is a public organization it was necessary to select entrepreneurial success measurements other than traditional financial measures which are not easily generalizable to public sector organizations.

Firm's Expressed Desire to Pursue an Entrepreneurial Mindset

Having and implementing the entrepreneurial mindset is the latest trend for many companies (McGrath & MacMillan, 2000; Adams, 1995). Companies attempt to assess how best to harness the “entrepreneurial magic” that they so often hear about and see going on around them (Hamel, 1999:1). While many firms want the tangible benefits that being entrepreneurial can offer, few are willing to invest the time and effort to implement the entrepreneurial mindset systematically. As McGrath and MacMillan (2000:2) point out a number of key elements must be addressed before a firm or individual can claim the benefits of being a “habitual entrepreneur.” Some of the more notable steps include: establishing the entrepreneurial frame, stocking the “opportunity register”, focusing on the best opportunities, and implementing “adaptive execution” (McGrath & MacMillan, 2000:5). For this thesis research, the general framework outlined by McGrath and MacMillan (2000) was used to distinguish which firms’ business efforts were actually utilizing the entrepreneurial mindset as compared to those firms relying on other business methods.

Firm's Position

The position of the firm in their respective industries was determined using the most current industry indexes according to the Fortune Magazine rankings. The firms' position in their own industry serves as an indicator of their successful implementation of the entrepreneurial mindset. Because this thesis effort is exploratory in nature only those firms who have been noted for their success with implementing entrepreneurship have been considered. The aim was to compare the experiences of these entrepreneurially successful firms with the potential experience DoD organizations might have. This method of comparison is known as benchmarking.

Hammer and Champy (2001) argue that benchmarking is best done from a global perspective. They posit that, "Essentially, benchmarking means looking for the companies that are doing something best and learning how they do it in order to emulate that" (Hammer & Champy, 2001:137). The potential downfall of this practice is that by looking at the best it is unlikely an organization seeking to better itself will do so *beyond* the current best in their industry (Hammer & Champy, 2001:137).

The inherent goal in competition should be to be the best outright. Rather than aiming to be as good as the current best it would be more beneficial for a firm to try to become resoundingly *better* than the current best. To avoid being satisfied by only limited improvement in a firm's particular industry, a variety of firms were selected from different industries. The diversity in both the firms selected and their industries will further demonstrate that these firms are in a superior position when compared to their peers.

Rate of Innovation

One of the assumptions for this research effort is that the rate of innovation increases after the entrepreneurial mindset is introduced into the system. Because of this, the rate of innovation is measured on an annual basis for each firm. In this research endeavor, Damanpour's (1987) example is used to better understand how to analyze the adoption of innovation in public organizations, specifically public libraries, to detect entrepreneurship in public organizations. While the firms being used for this research are *private*, there is precedence for public organizations, such as the government, to observe the actions of private sector firms and apply their entrepreneurial ideas to the public sector.

Rather than separate the types of innovation that were present in the selected firms, each of the three types of innovation that Damanpour (1987) identified have been examined concurrently. The purpose of this thesis is to assess entrepreneurship and not to analyze innovation therefore innovation is defined as the, "the adoption of an idea or behavior new to the adopting organization" (Damanpour, 1996:694). This broad definition of innovation at an organizational level is sufficient for the purposes of this research. What type of innovation the firm develops is not the variable of interest in this thesis, but rather, the interest lies in whether an innovation was adopted by the organization, irrespective of the *type* of innovation.

Number of Employees

Since the ultimate goal of this research is to gather results generalizable to the DoD and especially large DoD organizations it was important to investigate the characteristics of large firms. Only firms that have at least 20,000 employees were

included in this research. An entire body of literature discusses the effects of a company's size on its ability to change (Conceicao, Hamil & Pinheiro, 2002; Tuggle, 2002; Borins, 2000; Reilly & DiAngelo, 1984). I posit that just as it is difficult to compare the implementation of the entrepreneurial mindset in small organizations to the implementation in larger organizations; implementing the entrepreneurial mindset in DoD organizations will be a unique experience that is most closely represented by looking at implantation in large private sector companies.

Reilly and DiAngelo (1984:25) state that there are three developmental stages for an organization: The entrepreneurial stage, the process of transition, and the maturity stage. They state that in this last stage,

“The firm grows older, larger and more complex. There is a greater need to delegate decision-making tasks to functional and lower level managers, to professionalize and institutionalize the intelligence-gathering and information process functions, and to integrate the efforts of decision makers by formal means (i.e., committees and planning sessions)” (Reilly & DiAngelo, 1984, 27).

Each of these layers of complexity within the organization is the sort of issues that DoD organizations will need to take into account when considering how best to implement the entrepreneurial mindset within their specific organization.

Organization Size

While the number of employees usually increases as the size of the organization increases, that is not always the case. There are both a large number of people and a large organization with which DoD organizations must contend. Similar to the term entrepreneurship, *organization* can have a number of meanings (Arrow, 2000; Baden-Fuller, 1995). For this paper, Rogers' (1995) definition will be used,

“An *organization* is a stable system of individuals who work together to achieve common goals through a hierarchy of ranks and a division of labor. Individual behavior in an organization is relatively stable and predictable because organizational structure is characterized by predetermined goals, prescribed roles, an authority structure, rules and regulations, and informal patterns” (Rogers, 1995: 403).

Determining the extent to which entrepreneurship is taking place or can take place in DoD organizations will rest chiefly on how large organizations were able to work the figurative magic of the entrepreneurial mindset through the complexity of their organizations. The lessons that they have to offer will be of great value to the DoD.

Number of Operating Locations

Organizations within the DoD may have installations in the U.S. and across the world. That diversity is characteristic of the various organizations that make up DoD. DoD organizations must deal with cultural and logistical problems as well as the more common logistical dilemmas that face private sector organizations. This directly affects the way in which DoD organizations will be able to incorporate entrepreneurship in their practices. By looking at only those firms that have multiple operating locations, the data gathered on the firms will offer more useful information about entrepreneurship for the purposes of this research.

Company Age

New companies have a more short-term focus than more experienced firms. For older firms there is often less intense concern about survival once they are established than a new company would experience. Older firms have a larger stake in the status quo (Hitt & Bartkus, 1997). Because of this trend, only those firms that have been in existence for at least 10 years were used in the research. Again, this criterion is meant to

assist in narrowing the entrepreneurial characteristics identified within the firms to only those characteristics that will be applicable to DoD organizations.

Table 1. Firm Selection Criteria

	Expressed Desire ¹	Firm's Industry Position ²	Rate of Innovation ³	Number of Employees ⁴	Size of Organization ⁵	Operating Locations ⁶	Age of Company (in years)
3M	McGrath	4	McGrath ^l	71,669	3M	60	100
AT&T	McGrath	3	McGrath	117,800	AT&T	200	126
Canon	McGrath	190 ^a	McGrath	93,620	Canon	203 ^k	66
Dow	Enbar	2	Enbar	52,689	Dow	170	106
Duke/Fluor Daniel	McGrath	3 ^b	McGrath	74,000 ^g	Duke/Fluor Daniel	37	14 ^l
GE Capital	Hamel	1	Hamel	315,000 ^h	GE Capital	110	111
Intel	McGrath	1	McGrath	83,400	Intel	50	35
Kone	McGrath	n/a ^c	McGrath	22,949	Kone	40	93
Mobil	McGrath	1 ^d	McGrath	97,900 ⁱ	Mobil	36	121
NCR	McGrath	8	McGrath	30,445	NCR	73	119
Shell	Hamel	8 ^e	Hamel	91,000 ^j	Shell	60	111
Xerox	Adams	6	Adams	78,900	Xerox	60	97

1. Notes scholar who indicated firm's expressed desire to be entrepreneurial (see bibliography for full citation)
2. According to Fortune Magazine's Fortune 500 2002 rankings. Industries within which the firms are rated are listed in order as follows: miscellaneous, telecommunications, (industry not specified), chemicals, energy, diversified financials, semiconductors and other electronic components, escalator, petroleum refining, computers and office equipment, petroleum refining, computers and office equipment
3. Notes scholar who indicated the firm's rate of innovation to be higher than their peers
4. Hoover's online (www.hoovers.com) number of employees for 2001
5. Assessment of each firm's size was largely based on the firm's presentation of its structure as represented on the firm's official webpage. This presentation was then collaborated using Hoover's online (www.hoovers.com)
6. Noted by the number of countries in which the firm currently operates. These figures are estimates since each of the firms is constantly increasing their number of locations whether as an individual effort or as a joint effort. This information was gathered from the firm's respective websites.
 - a. This ranking reflects Fortune Magazine's 2002 Global 500. Although Hoover's online noted that Canon U.S.A., Inc. controls over 20% of the U.S. copier market.
 - b. Ranking applies to Duke Energy although Fluor is ranked number one in the engineering and construction industry
 - c. Fortune Magazine does not rank companies within the escalator industry although Kone's official web page claims that he firm is "One of the world's leading escalator companies" (www.kone.com)
 - d. Ranking reflects ExxonMobil
 - e. Royal Dutch/Shell Group's ranking reflects Fortune Magazine's 2002 Global 500
 - f. Innovation is so important to 3M that the firm's quest to achieve a high rate of innovation is part of the firm's mission statement (www.3m.com)
 - g. Total reflects a combination of information about Duke Energy found on Fortune Magaizne's website and information listed on Fluor's official website.
 - h. This number reflects employees for the entire GE Company in 2002
 - i. Mobil's number of employees actually reflects the entire Exxon Mobil Corporation
 - j. Shell's number of employees actually reflects the entire Royal Dutch/Shell Group of companies
 - k. Reflects firm's number of "Group Companies" according the the firm website
 - l. This figure indicates when the firms merged, although Duke Energy was founded in 1904 and Fluor was originally incorporated in 1924.

Table 1 outlines the selection criteria for each of the firms included in the research effort. The majority of the data shown in the table was compiled from the official websites of Fortune Magazine, Hoover's, and the individual firms. Unless

otherwise noted the data reflects 2002 numbers. The key below **Table 1** explains all notations made in the table. Numbered notations in the first row relate to the firm selection criteria while lettered notations relate to the data gathered on a specific firm.

Table 1 is set up so that column one lists the firms included in the research while column two indicates which entrepreneurship scholar recommended each firm, based on the firm's expressed desire to implement the entrepreneurial mindset within its firm. In most cases this recommendation was culled from the scholar's published work, although McGrath also offered some recommendations over electronic mail (McGrath, 2002). In the first row **Table 1** shows that 3M was recommended for study by McGrath. In 2002, 3M was ranked fourth in its industry by Fortune 500. Column four again indicates the entrepreneurship scholar who identified each firm's rate of innovation to be higher than the rate of innovation at comparable firms. In column four 3M is noted for its rate of innovation by McGrath. There is a lettered notation in the fourth column for 3M since in this case data from the firm's website was also used as proof of the high rate of innovation at 3M.

In column five the number of employees is listed for 2001 unless otherwise indicated, so in that year 3M had 71,669 employees (Hoover's online, 2003). In column six the information regarding the size of each organization was gathered from the firm's websites and then collaborated with information available on Hoover's. Column six shows that 3M's size met the firm selection criteria for this research effort according to the information available on the firm's website. In column seven the number of operating locations was estimated based on the number of countries where the firm has

operations, so 3M has operating locations in approximately 60 countries. Finally, the age of the firms was determined in years in column eight. 3M is one hundred years old.

Organizational Characteristics

Thus far, this literature review has outlined what entrepreneurship encompasses, both in the history of the field and for the future; the applicability of intrapreneurship for this research and the criteria that have been used in the past as well as those that were used for this thesis, for gauging the implementation of the entrepreneurial mindset. Now the focus shifts to the specific organizational characteristics and conditions that can cause a firm to attempt to implement the entrepreneurial mindset. Particularly, the antecedents, barriers encountered, and performance outcomes historically experienced by firms who have sought to implement the entrepreneurial mindset will be analyzed in this section. Finally, the literature review supports the idea that applying the best procedures from the commercial sector to DoD organizations has great potential benefits for these government organizations.

Antecedents

In order to understand where entrepreneurship can take us in the future it is important to understand figuratively where we have already been. This section will discuss how entrepreneurship has been addressed in the past and how it is currently being operationalized in the present, and explain which specific conditions existed that made firms decide to take action towards the entrepreneurial mindset.

According to Luchsinger and Bagby (1987:11) the setting and the opportunity for “entrepreneurial activity” have a “strong impetus” for predicting whether individuals can

implement what we now describe as the entrepreneurial mindset. While Luchsinger and Bagby's original work focused almost exclusively on the entrepreneur as an individual other scholars of entrepreneurship have since advanced the idea that entrepreneurship does not necessarily have to be tied to one individual, but can actually be tied to an organization or a group of individuals (Kuratko, Ireland, & Hornsby, 2001; Aldrich & Martinez, 2001; Cooper, Markman, & Niss, 2000; Hamel, 1999).

For the purposes of this thesis research the focus is on how the entrepreneurial mindset can be advanced in organizations even without a supposed expert entrepreneur at the helm. While it is important to realize that originally scholars in the academic field of entrepreneurship tended to focus on individual entrepreneurs and small business startup ventures, the academic field has since advanced and now recognizes many more opportunities for the entrepreneurial mindset to be used than were originally acknowledged (Aldrich & Martinez, 2001; Morris & Jones, 1999; Zahra, 1999).

Kuratko, Ireland and Hornsby (2001:60) observe that, "A virtual revolution about the value of entrepreneurial actions as a contributor to firm performance took place from the late 1980s throughout the 1990s. This was a time during which companies were redefining their businesses, thinking about how to most effectively use human resources and learning how to compete in the global economy." Due to the "virtual revolution" mentioned above, many firms altered their business approach in an attempt to become more entrepreneurial and maintain a top notch business position in their industry. Zahra, Jennings, and Kuratko (1999) state that,

"...some of the world's best-known companies have had to endure reorganization, downsizing, and restructuring. These changes have altered the identity and culture of these firms, infusing a new entrepreneurial spirit throughout their operations. After years of restructuring, some of these

companies bear little resemblance to their ancestors in their business scope, culture, or competitive approach. Change, innovation, and entrepreneurship are now highly regarded words that describe what successful companies do to survive” (5).

Barriers Encountered

Aldrich discusses two kinds of legitimation problems facing entrepreneurs: Low cognitive and low sociopolitical legitimacy (2000: 212). He outlines how one of the barriers within organizations becoming more entrepreneurial is that they are caught in a theoretical Catch-22 where they do not receive full support from higher ups before they prove the worth of their entrepreneurial ideas and yet they encounter great difficulties when trying to prove the merit of their ideas without the support of upper management (Aldrich, 2000: 212). It is all but impossible to successfully implement new ideas without upper management support and yet the upper management is hesitant to give that support freely, even to the most promising of entrepreneurial ideas. Such a phenomenon keeps the organization from being entrepreneurial.

One of the first barriers that may intimidate some managers who are considering transitioning their firm to be more entrepreneurially minded in the future is the element of time. Most managers already feel limited by their time resources so to attempt a project that will take an unknown amount of time can be problematic (McGrath & MacMillan, 2000). Empirical work warns that the potential gains of corporate entrepreneurial activities and processes may take years to be evident (Zahra & Covin, 1995), which can be devastating to stakeholders who insist on relatively fast results. In the often fast paced business world even a few years can seem like forever.

“Managers in large companies know that innovation is important, but they are uncomfortable if they cannot keep it under control. They often deal with this problem by applying the same plan-the-work and work-the-plan approach used in

the rest of the business. They try to regulate the process of innovation by commissioning separate groups to generate and implement ideas. It does not really matter whether these commissions are bestowed on people in R and D [Research and Development], new product development, corporate venturing or special task forces. The company has pinned a badge on the groups' chests and designated them the innovating force. While this approach can produce some innovation, others who do not have this badge get a message that it is not their job to have or implement new ideas" (Pryor & Shays, 1993:42).

The desire of most managers to control the unknown can be a daunting barrier to implementing entrepreneurship in organizations. There is an element of entrepreneurship that is unknown and therefore uncontrollable and unless managers can accept that fact and work around it there is little chance they can lead their firm into more entrepreneurial waters. Additionally, anyone in an organization should be able to have their innovative ideas heard in a proper place. Using employees already on staff can be of great benefit to firms rather than a barrier (Hamel, 1999).

"Intuitively, in an environment where calculated risks are encouraged, an inevitable amount of failure should be expected" (Tuggle, 2002: 6). Tuggle (2002) indicates what should happen in the ideal situation, but unfortunately this is often not the experience many companies find when they begin to implement the entrepreneurial mindset within their company (McGrath & MacMillian, 2001). Instead most firms reward success and chastise failure even if the failure may have taught those within the firm valuable lessons. Sometimes it can be difficult to get support from high ranking officials without proven results and entrepreneurship tends to work the opposite direction where positive results come second and support must come first (Hamel, 1996).

Barriers are especially noticeable in large organizations where there tends to be a more hierarchical structure. Reilly and DiAngelo (1984:24) refer to this when they say

that, “The large bureaucratic structures in the United States, through policy, rules and regulations, have closed off the growth and entrepreneurial potential of a major portion of their workforces, both managers and other employees.” Concurring, Luchsinger and Bagby (1987:12) state that, “The classic bureaucratic or mechanistic organization makes an inhospitable environment by its rigidity, risk aversion, and structural sluggishness.” In order for the entrepreneurial mindset to be accepted within an organization the barriers above have to be overcome or at least mitigated as much as possible.

Outcomes

The purpose of implementing the entrepreneurial mindset is to improve the company’s performance or process so that performance can ultimately be improved. Covin (1999:47) states it best when he says, “The linkage between corporate entrepreneurship and firm performance has been empirically documented in methodologically rigorous research.” He goes on to say that, “...corporate entrepreneurship produces superior firm performance for identifiable, defensible, and strategically valid reasons” (Covin, 1999:47). Basically, firms moved to entrepreneurship because they thought that implementing the entrepreneurial mindset was a way to help them do their business better, whether that be by inventing a new product or implementing a more efficient process. “Corporate entrepreneurship has long been recognized as a potentially viable means for promoting and sustaining corporate competitiveness” (Covin & Miles, 1999:47). Firms want to remain competitive in their industry, just as DoD organizations want to be competitive with their counterparts in other countries around the globe.

Most often scholars and managers use financial indicators to measure the outcome of entrepreneurial endeavors (Fiore & Lussier, 2002). While this financial approach can be useful in determining success for private sector organizations, it does not lend itself to being applied to public organizations. Because of this, it is important to find non-financial parameters by which to gauge success in both the private and public sector. These generalizable parameters should allow for more accurate comparisons to be made between private and public sector organizations.

Acordia Inc.

Once such firm who formally began its transformation process in 1986 was Acordia Inc. (Kuratko, et. al, 2001). In the early 1980s L. Ben Lytle, the CEO and chairman of the board of directors, assessed that his firm Blue Cross/Blue Shield of Indiana was experiencing “environmental discontinuities” or a lack of coherence, and changes (Kurato, et. al, 2001). Lytle was worried that the growth of his firm’s innovative ability was being stunted by the firm’s bureaucratic structure which discouraged even informal efforts by employees to entrepreneurially develop products, processes or market innovations (Kurato, et. al, 2001). Bartlett and Goshal (1996) indicate that there is evidence in entrepreneurial research, which supports Lytle’s fears about the constraints his firm faced in the early 1980s to becoming a more entrepreneurially minded firm.

There are a variety of characteristics that Acordia, Inc. and firms in many other industries face as they attempt to be more entrepreneurially minded. Employees need to be made to understand why and how the firm is trying to change and how they, as employees can help. The way that Acordia, Inc. approached this situation was by

training their employees at all levels in the firm to better prepare the employees to assist the firm in implementing the entrepreneurial mindset in the firm's business practices.

“Early in the journey, a corporate-entrepreneurship training program was started to introduce employees to the importance of entrepreneurial actions and to describe what would be done to elicit and support them. Upper-level managers took other early entrepreneurial actions, including changing the firm's name from Blue/Cross Blue Shield of Indiana to the Associated Group, and organizing the new company into operating units. The units were batched by industry, geography, demographics, and products, permitting a focus on mid-market customers' needs” (Kurato, et. al, 2001:60)

While details such as operating groups may not apply to the way every firm decides to approach implementing the entrepreneurial mindset, the description from above is very useful in understanding the level of commitment that such an endeavor takes by members at all levels within the firm. While workers had to be trained and also buy into the new business approach, upper-level managers had to restructure the hierarchy of the firm to better fit the firm's expressed goals regarding entrepreneurship.

Entrepreneurship in Government

The current gap in the literature translates into very little literature which directly connects entrepreneurial thinking to the government and other non-profit organizations or analyzes the potential benefits for such a connection (Reed, Smith & Holt, 2003). Here the term government is meant to include all non-profit organizations. Initially entrepreneurship research for the public sector looked at characteristics of public sector innovators (Borins, 2001) as well as inventors in national laboratories (Kassicieh and Radosevich, 1996). Weinstock (2002) even gives examples of innovative policy within government organizations such as fee for service plans and working capital organizations. Despite the small signs of progress it is clear that there is still relatively little research on

how more entrepreneurial efforts could effect the government and how those entrepreneurial efforts could be implemented.

Chapter Summary

While others have found that the implementation of the entrepreneurial mindset in large organizations has resulted in many successes and some failures, a thorough review of the extant literature reveals no examination of the application of the entrepreneurial mindset to DoD organizations. This thesis endeavor aims to address this gap in the literature in order to help guide DoD organizations on how to most effectively implement the entrepreneurial mindset.

This chapter served as an overview of the literature on the topic of entrepreneurial research to date. Proper motivation was given for how entrepreneurship can benefit public organizations such as those organizations within DoD. The research gap which this thesis endeavor attempts to address was duly noted. Now that the seven firm selection criteria have been explained an understanding of the methodology for this thesis can be analyzed in chapter three.

III. Methodology

Chapter Overview

The purpose of this chapter is to describe the research objectives, and the research methods used to meet those objectives. The case study methodology and the reason it was employed for this thesis effort are explained below, followed by a more in depth explanation of the research design. The data collection process is detailed followed by a brief discussion about the interview questions. The means by which validity and reliability concerns were addressed in the research is highlighted.

Research Objectives

Evaluating current trends in large commercial firms that have successfully implemented the entrepreneurial mindset enables this study to evaluate the objective of which characteristics of the entrepreneurial mindset offer potential value to DoD organizations. The seven distinct characteristics, discussed in Chapter 2, allow this study to identify those firms that have successfully implemented the entrepreneurial mindset. Analysis from data collected from interviews with members of the firm and through literature review provides a basis for the application for DoD organizations.

Research Design

Commenting on the work of other scholars (Firestone, 1978; Gioia & Pitre, 1990; Kuhn, 1970) from the field of research methods Chriswell (1994) states that, “The design of a study begins with the selection of a topic and a paradigm. Paradigms in the human and social sciences help us understand phenomena: They advance assumptions about the social world, how science should be conducted, and what constitutes legitimate problems,

solutions, and criteria of “proof” (Criswell, 1994:1). The case study design provides flexibility in comparing the success of firms in implementing the entrepreneurial mindset. Ellram (1996:95) states that, “...without proper research design, execution and data analysis, case study research will produce poor results.”

Criswell (1994:1-2) goes on to define a qualitative study as one, “...designed to be consistent with the assumptions of a qualitative paradigm. This qualitative study is defined as an inquiry process of understanding a social or human problem, based on building a complex, holistic picture, formed with words, reporting detailed views of informants, and conducted in a natural setting.” In this study, collection of qualitative data enables key officers within each of the firms to share their opinions on what made their firm more likely to embrace the entrepreneurial mindset. Additionally, a qualitative study allowed the officers within the firm to speak to what barriers the firm encountered when attempting to implement the entrepreneurial mindset and how they as a firm are working to maintain the entrepreneurial spirit within their firm.

This richness of this data cannot adequately be captured in a quantitative format, which Criswell (1994:2) describes as, “...an inquiry into a social or human problem, based on testing a theory composed of variables, measured with numbers, and analyzed with statistical procedures, in order to determine whether the predictive generalizations of the theory hold true.”

Methodology

When selecting which research methodology to use there are three conditions to consider “(a) the type of research questions posed, (b) the extent of control an investigator has over actual behavioral events, and (c) the degree of focus on

contemporary as opposed to historical events” (Yin, 1994:4). As noted previously in Chapter 2, even though the field of entrepreneurship has been studied for quite some time it is still a very contemporary issue. Each of the people interviewed about their respective firms shared the situations and benefits that their company is currently experiencing.

Yin says that, “The technical definition begins with the scope of a case study:

A case study is an empirical inquiry

- Investigates a contemporary phenomenon within its real-life context, especially when
- The boundaries between phenomenon and context are not clearly evident” (1994:12-13).

“Although definitions of the term case study have become broader, an overriding concern for generalizability remains at the root of all definitions” (Jenson & Rodgers, 2001:236). For the purposes of this research effort the comparative studies of cases was used. A comparative case study is one of the types of cumulative studies, which integrate the findings of several case studies (Jenson & Rodgers, 2001). Jenson and Rodgers (2001) state that,

“The objective of the comparative study...is cross-unit comparison within-unit synthesis. Comparisons are made in an attempt to tease out generalizations about an underlying commonality reflecting a policy, process, program, or decision. Comparative studies broaden the perspective to include many different entities, and thus offer insights that can be unearthed from comparative analysis” (Jenson & Rodgers, 2001:238).

For the purposes of this research the cross-unit comparison will be made between the different entrepreneurship spokespeople for each of the firms.

In response to critics of the relevance of the case study method Ellram (1996:104) states, “Clearly, proper application of the case study method requires extensive training

and/or self-study, as does any other research method. It is only a misunderstanding of the case study method that causes people to believe otherwise.”

Since this research is focused on generating ideas for how DoD organizations can become more entrepreneurial, there are a number of questions that must be answered including: 1) what barriers should these organizations expect to encounter, 2) what are the benefits of taking an entrepreneurial approach and 3) what approaches have private sector firms used most successfully in the past? Faced with these sorts of questions Yin recommends a case study as the desired method for research.

Data Collection

Sample

After reviewing the extant literature and culling the opinions of experts in the academic field of entrepreneurship, thirty-three large firms were initially identified from archival sources for further review. The list of selected companies was further refined based on an analysis of archival data regarding the companies’ performance in the following areas: 1) firm’s desire to work to be entrepreneurial; 2) position in the firm’s industry; 3) rate of innovation since adopting the entrepreneurial mindset; 4) number of employees; 5) size of the organization; 6) number of operating locations; 7) and age of the company. These firms were contacted and agreed to participate in the research effort. Specifically, they agreed to make the Chief Information Officer (CIO) or another upper level manager, intimate with the details of the firms’ process of implementing the entrepreneurial mindset in their firm, available to be interviewed. Many of the initial firms (27/33) were identified by entrepreneurship scholar through personal correspondence (McGrath, 2002; Markman, 2002). In addition, firms were identifiable in

literature in which the firms were praised for their success with entrepreneurship (Christensen, 2000; McGrath & MacMillan 2000; Enbar, 1999; Hamel, 1999; Adams, 1995).

In some cases the author of the article had actually worked with and/or interviewed members of the firm in question, about the firm's implementation of the entrepreneurial mindset (McGrath & MacMillan, 2000; Enbar, 1999; Hamel, 1999). In other cases the firms were noted for their successful implementation of the entrepreneurial mindset based on products and/or services the firm was able to provide its customers (McGrath & MacMillan, 2000; Christensen, 2000; Hamel, 1999). Based on the archival research certain firms were identified as having a specific entrepreneurial processes or product in place.

Within the database of firms created, information regarding the specific entrepreneurial product, service or process was recorded. Later, the data about which firms had a specific entrepreneurial process or product, that had all ready been identified, were ranked as "A" firms. All of the firms that had been mentioned in the literature but were not connected with a specific process or product were listed as "B" firms. Initially 19 of the 33 firms were given the designation of "A" firms. It was important to focus on firms that have identifiable products and processes since the purpose of this study is to identify characteristics of private sector firms who have been successful with their entrepreneurial endeavors. Part of being successful is being able to distinguish between products and processes that exist in large part because of the firm's drive to be more entrepreneurial (McGrath & MacMillan, 2000; Hamel, 1999).

Primary contact information was identified for each of the firms using a combination of firm websites and business listings available in the AFIT library. The primary source used was *The Corporate Directory of U.S. Public Companies* (1999). The following information was compiled: the firm name, number of employees, business address, name of known entrepreneurial product or process, and the corporate headquarters phone number. As an Excel database of the firms was created, the entries for some of the firms were left blank due to information unavailable at that time.

Initial contact with the 33 firms was then conducted. Initial contact resulted in identifying the firm CIO's name and contact information. If the firm did not have a CIO an attempt was made to get contact information for the person in charge of product development or someone directly involved in the firm's noted entrepreneurial process.

After the person most intimate with the entrepreneurial practices of the firm was identified he or she was contacted to set up a guided phone interview. These interviews lasted approximately one hour and were followed by an email numerical assessment survey, both of which are discussed in more detail below.

Phone interviews were recorded and then transcribed by an outside professional source. Additional notes were taken at the time of the interview to supplement the recordings. Transcripts were analyzed for pattern matching among the entrepreneurial practices of the companies. If further information was required from a specific company they were contacted again by phone or email.

Interview Questions

Based on the literature review and three examples of entrepreneurial mindset survey instruments used in the past by Tuggle (2002), Markman (2002), and McGrath

(2002) a list of 5 open ended phone questions were compiled for a guided interview. In addition these three survey instruments provided the foundation for 35 numerical assessment questions that participants were asked to complete via email. Both the list of survey questions and the list of construct variables were then checked in a blind review, by three experts in the field of entrepreneurship. The open-ended interview questions can be viewed in **Table 2** and the complete qualitative questionnaire is in **Appendix P**.

Reliability

The quality of a research design is evaluated based on reliability and validity. According to Dooley (2001:93), “Reliability assesses the extent to which a measure reflects some consistent aspect of people or events rather than random error.” Reliability is particularly important in case studies, because if the proper measures are not used for the study then the data gathered will likely not answer the question at hand. According to Ellram (1996:104), “In a case study context, there are two keys to reliability: use of a case study protocol, and development of a case study data base.”

“Reliability measures include different types of correlations: interim, test-retest, parallel forms, and interrater” (Dooley, 2001:93). One of the most essential factors of reliability is to make sure that the research process is concisely documented from beginning to end. This allows other researchers to examine the process and even repeat it if they desire. By having a result with high reliability, we make it more likely for others to obtain the same result in another study as long as that researcher follows the procedures that we have outlined when it comes to their data collection.

To increase reliability, themes were identified among the firms’ qualitative responses by two different sources. Once the two different sources had each created a list

of patterns that had emerged from the qualitative data they came together to compare and discuss the patterns they had identified. While this process involved informal scrutinization of the data by individual sources all discrepancies were discussed and adjusted until both researchers were in agreement.

Researchers often critique case studies for their lack of generalizability to a larger universe (Ellram, 1996). But this research is not meant to be generalizable in that way. We address this issue by using more than one company from a variety of industries in order to gain a wider perspective on the issue of entrepreneurship. “Case studies may be used to create theory to then test with surveys, or as a follow up to surveys to provide greater insight” (Ellram, 1996:97). This is precisely what this research is geared to do, “provide greater insight” about the reasons and ways that firms go about trying to be more entrepreneurial in their processes, so that DoD can get ideas about how to follow suit.

Validity

Dooley states that, “Validity assesses the extent to which the measure reflects the intended construct, criterion, or content domain” (2001:93). “...Validity assessment includes several methods: construct, criterion, and content” (Dooley, 2001:93). “...construct validity often plays the most important role in social research because it addresses the threat that the measures employed do not pertain to the theory in question” (Dooley, 2001:93).

“If a measure has high validity, it must also have high reliability. But high reliability does not assure high validity” (Dooley, 2001:93). In light of this, two experts in the entrepreneurial field reviewed the interview protocol to make sure that the

constructs, which the interview questions represent, were accurately depicted in the survey.

Chapter Summary

This chapter described the research objectives and research design. Potential concerns about validity and reliability were addressed and the data collection process was explained in detail. Now that there is a full understanding of the methodology employed it is time to move on to an outline of the data gathered.

IV. Results

Chapter Overview

The purpose of this chapter is to explain the results of the research and analyze some of the possible implications of those results for the field of entrepreneurial research and for organizations, such as DoD, that may attempt to implement the entrepreneurial mindset in the future. First, a brief background on each of the twelve firms interviewed is given. For those firms that were recommended for study based on the success that firm has had with a specific entrepreneurial product or process that product or process is named. The results from the qualitative survey are outlined with all five qualitative questions listed in **Table 2**. For each question a brief discussion is given regarding some of the more prominent patterns that emerged from the data. The qualitative section is followed by a discussion of the quantitative results. This discussion starts by pointing out the average highs and lows. Highlights are detailed but the full list of qualitative results is listed in **Appendices M-O**.

Background on Firms

As discussed in chapter two the firms included in this research effort were selected due to their relative success implementing the entrepreneurial mindset in their own organizations. Since the nature of the firm's business affected the way the strategic leaders from each firm answered questions about their firm's experiences implementing the entrepreneurial mindset a brief explanation of each firm is listed below. Most of the current firms are the result of at least one partnership or merger and in some cases the

firm has merged more than once. Each of the firms market a product or service and some of them market a number of products and services simultaneously.

3M

3M started out as a mining company in 1910. Since they were not finding corundum, the mineral they were looking for, in Duluth, Minnesota they decided that they needed to develop a laboratory to develop more marketable products (3M, 2002). 3M Three-M-ite Abrasives Cloth was 3M's first "exclusive" product (3M Worldwide, 2003). Since the firm's inception, it has been responsible for a wide variety of breakthrough products, from Scotch Tape to Post-it Notes (3M Worldwide, 2003). Originally, the firm focused more on abrasives, masking tape, cellophane tape, roofing granules and adhesives (3M Worldwide, 2003). 3M has been involved in international markets since 1929 and continues today to be a major global player with operations in more than 60 countries (3M Worldwide, 2003).

AT&T

AT&T serves a variety of customers, including businesses, consumers and the government, through voice, video and data communications (AT&T, 2003). "During the 19th century, AT&T became the parent company of the Bell System, the American telephone monopoly" (AT&T, 2003). Broken up into eight companies in 1984 by an agreement between AT&T and the U.S. Department of Justice the original organization has evolved over time (AT&T, 2003). In 1995, AT&T voluntarily restructured itself into three separate publicly traded companies (Hochheiser, 2002). Lucent Technologies focused on systems and equipment, while NCR was focused on the computer related

elements of the organization, allowing the communications service section to retain the AT&T name (Hochheiser, 2002). Five years later the firm split again, this time to form AT&T Wireless, AT&T Broadband and AT&T (Hochheiser, 2002).

Canon

Canon started out in the early 1940s as a Japanese camera company (Canon, 2003). The firm which originally focused on basic imaging quality is now involved with digital and optical technology that have potential applications in a wide range of areas from television to medical fields (Canon, 2002). The firm is very technology focused and in recent years has been one of the top companies in the U.S. to file for patents (Canon, 2002). The U.S. Canon organization is a subsidiary of the Japanese Canon, Inc. Approximately 90% of research and development, and manufacturing are done in Japan (Canon, 2002).

Dow

Started in the late 1890s, Dow Chemical Company is now the largest chemical company in the U.S. (Hoover's Online, 2003). Dow is a science and technology company that focuses on chemicals, plastic and agricultural products and services (Dow, 2003). The firm's customers span across 170 countries (Dow, 2003). Some of Dow's most well known products include performance plastics such as adhesives, sealants and coatings, as well as herbicides and insecticides (Hoover's Online, 2003).

Duke/Fluor Daniel

Duke/Fluor Daniel was formed in 1989 when Duke Energy and Fluor Corporation joined in partnership (Duke/Fluor Daniel, 2003). The company deals with all aspects of

power generation and is one of the world's largest builders of fossil-fueled power plants (Hoover's Online, 2003). Duke/Fluor Daniel offers engineering, procurement, environmental and construction services, in addition to operations and maintenance services, for both combustion turbine and coal-fire facilities (Hoover's Online, 2003). The firm's customers range from utilities to smaller cogeneration units (Hoover's Online, 2003). Duke/Flour Daniel helps negotiate fuel and electricity supply contracts as well as doing upgrades to existing power plants (Hoover's Online, 2003).

GE Capital

General Electric Capital Corporation is a diversified financial services company dealing with commercial finance, consumer finance, equipment management and insurance (GE Capital, 2003). GE Capital serves both consumers and businesses in 47 countries (GE Capital, 2003). The parent company of GE Capital opened in the 1890s.

Intel

Intel was founded in 1968 to build semiconductor memory products (Intel, 2003). Now the firm is seen as the world's top semiconductor maker (Hoover's Online, 2003). Intel introduced the world's first microprocessor and is best known for its Pentium and Celeron microprocessors (Intel, 2003). Intel also makes flash memories and embedded semiconductors for the communications and industrial equipment markets (Hoover's Online, 2003).

Kone

Kone is the fourth largest elevator and escalator maker in the world (Kone, 2003). The Kone Corporation was founded in the early 1900s in Finland and was the first

Finnish company to go international (Kone, 2002). Kone has more than 800 operations in over 40 countries (Kone, 2003). Sixty percent of the company's sales come from the maintenance and modernizations business (Kone, 2003). One of the unique things about Kone is that in 1968 the company began to acquire elevator companies throughout the world without the resources or experience needed to integrate these newly acquired companies (Kone, 2002). Largely due to this lack of resources and experience, Kone was run as a "federation of local companies" for approximately 30 years before the firm had the desire and resources to create a more unified company (Kone, 2002: telephone interview).

Mobil

After the Mobil Corporation merged with Exxon Corporation in 1999, the newly formed Exxon Mobil Corporation became the world's largest integrated oil company (Hoover's Online, 2003). Globally, Exxon Mobil deals with oil and gas exploration, production, supply, transportation and marketing (Hoover's Online, 2003). The company supplies refined products to almost 120 countries under the Exxon, Esso and Mobil brand names (Hoover's Online, 2003). Mobil was specifically recommended for this research effort due to the firm's relatively recent introduction of its Speedpass. This product exemplifies Mobil's approach to implementing the entrepreneurial mindset.

NCR

Founded in the late 1800s, the National Cash Register Company was the first maker of mechanical cash registers (NCR, 2003). Some of the firm's most commonly known products include ATMs, point-of-sale terminals, and bar code scanners (Hoover's

Online, 2003). The firm became NCR Corporation in 1974 and was then acquired in 1991 by AT&T (NCR, 2003). Also in 1991, NCR purchased Teradata Corporation (NCR, 2003). NCR Teradata became the world's most powerful database for data warehousing (NCR, 2003). In 1994 the NCR name was changed to AT&T Global Information Solutions (GIS), but changed back two years later to NCR Corporation (NCR, 2003). In 1998, NCR moved away from computer hardware manufacturing and began to concentrate solely on the software and services components of their solutions portfolios (NCR, 2003).

Shell

Shell Oil Company part of Royal Dutch/Shell Group (Hoover's Online, 2003). Most of the Group's crude oil is produced in Nigeria, Oman, the United Kingdom and the U.S. (Hoover's Online, 2003). Shell Oil Company explores for, produces and markets oil, natural gas and chemicals. Shell mainly focuses on oil and natural gas originating in the Gulf of Mexico region (Hoover's Online, 2003). Sustainable development practices are gradually being integrated throughout Shell as a means to help Shell retain a competitive advantage as well as meet environmental concerns being expressed globally by the firm's consumers (Shell, 2003). Shell has received acclaim in the entrepreneurial world for its GameChanger process which seeks to access the firm's own employee resources for ideas about how to improve the firm.

Xerox

Xerox Corporation officially got its name in 1961, but the company's roots date back to 1906 (Xerox, 2003). Xerox invented the first automatic plain-paper office copier

and even delved into the manufacture and sale of mainframe computers up until the early 1970s (Xerox, 2003). While Xerox is best known for its color and black-and-white copiers, the firm also makes printers, scanners and fax machines (Hoover's Online, 2003). Aside from products, Xerox markets services such as consulting and document outsourcing (Hoover's Online, 2003). Xerox has a history of being technology driven and the firm has a long list of innovations credited to the firm's name (Xerox, 2003).

Qualitative Survey Questions

In **Table 1** the five open ended survey questions are listed. As mentioned in chapter 2 the purpose of asking these questions was to gather qualitative data about each of the firms from the perspective of a strategic leader within the firm. Each of the strategic leaders was asked all five of these questions and some of the strategic leaders were asked additional questions to clarify the answers they gave to the initial five questions.

Table 1
Open-Ended Interview Questions

Q21 What caused your company to pursue entrepreneurial ventures or new innovations?

Q22 Describe the key challenge that was faced regarding this venture or innovation.

Q23 Describe the barriers that had to be overcome to accomplish the challenge.

Q24 Would you say the organization as it existed at the time the venture kicked off was well designed for the venture—or were changes to the organization design required?

Q25 What were the expected benefits that compelled your company to strive to be more entrepreneurial?

After reviewing all of the completed transcripts it became evident that certain questions received similar and in some cases identical answers. Sometimes these identical answers to similar questions would even become evident when asking different questions of the same firm. For example when asking what caused firms to pursue entrepreneurship the strategic leader might say, “growth” and another firm might say that “growth” was one of the firm’s expected benefits for becoming more entrepreneurial. Q21 and Q25 were examples of questions that received very similar answers even though these questions were aiming at obtaining information about two very distinct explanations. Q21 was aimed at identifying antecedents while Q25 was aimed at defining expected outcomes. It is understandable in some ways how these two areas of research may appear at times synonymous.

Strategic leaders also answered in similar manners when asked Q22 and Q23. This phenomenon is explained in greater detail below with a comprehensive explanation of the themes mentioned by the strategic leaders for each firm. The patterns that emerged

in the responses for each of the qualitative questions are listed below. For a full list of the themes mentioned see **Appendix Q**. The transcripts from each of the interviews are also in the Appendix. They are **Appendix A-L** and are listed in alphabetical order.

Qualitative Responses to Q21

What caused your company to pursue entrepreneurial ventures or new innovations?

Patterns that Emerged:

Both Canon and Mobil expressed a demand for service or goods that were being created as a reason for their firms to pursue entrepreneurial ventures or new innovations. While Duke/Fluor Daniel boldly stated that part of their reasoning was that the firm was “capable” of being entrepreneurial. Canon agreed with this sentiment. Duke/Fluor Daniel also felt that their firm was capable of managing risk and this was an outlook that GE Capital shared as well. While many of the firms implicitly expressed a desire to improve or reinvent their process as a motivator for implementing the entrepreneurial mindset only AT&T, 3M and Xerox explicitly stated this sentiment.

Technologically based companies such as Canon, Intel and Xerox expressed that pursuing entrepreneurial ventures or new innovations was the very nature of their business. Dow, Intel and Kone were quick to credit their individual firm histories for their entrepreneurial drive. Duke/Fluor Daniel and Dow were the only two firms to mention profitability as a cause for pursuing entrepreneurial ventures or innovations although as we will see later in the themes of Q25; however these two firms were definitely not the only firms that hoped to see profit from being more entrepreneurial.

Finally, both Dow and Shell said that they needed to change their business practices to reach their “growth fantasy” (Dow, 2002).

Even though all of the strategic leaders were asked the same question about their respective firms, the themes that were mentioned only once encompass a wide diversity of answers. Though Shell’s strategic leader saw entrepreneurship as a way to stay competitive, AT&T’s strategic leader emphasized entrepreneurship as a way for a large firm to try to work simply. This is of course not to say that strategic leaders would not have agreed with one another’s different answers to the same question but it does take into account the richness of the different experiences represented in the data collected.

Intel saw innovation as one of its “added values” (Intel, 2002). Shell wanted to use entrepreneurship as a means to allow the firm to enter new product markets. As a financial company one of GE Capital’s main concerns were “balancing out,” or trying new ideas while not putting the balance sheet at risk (GE Capital, 2002). Kone noted such motivators as the firm’s company structure and the increasingly global environment as other reasons to move towards more entrepreneurial methods. Mobil wanted to gain customer loyalty and address issues of customer “speed” and “convenience” through entrepreneurial products such as Speedpass (Mobil, 2002). The strategic leader at NCR was the only person to mention the prominent role that the Board of Directors played in the firm’s decision to focus on entrepreneurship in addition to the firm’s desire, “to bring out best practices in house” (NCR, 2002).

Qualitative Responses to Q22

Describe the key challenge that was faced regarding this venture or innovation

Patterns that Emerged:

The most noted challenge among the firms regarding an entrepreneurial venture or innovation was the challenge of selectivity. AT&T, Duke/Fluor Daniel, Canon, Shell and Xerox all mentioned how hard it was for their firms to identify worthy concepts. The strategic leader at Duke/Fluor Daniel expressed this sentiment best when he said,

“You can be entrepreneurial, and if you’re not selective, you are going to get into some deals that will cost you money, and waste certain efforts of the workforce that you are trying to make very efficient. You can’t avoid getting into some deals that maybe are less than economically attractive, or less than the risk profile you are looking for, but if you don’t have a good screening process, and you don’t adhere to a regiment of selectivity, you’re going to find yourself in trouble as an entrepreneur” (Duke/Fluor Daniel, 2002: telephone interview).

Interestingly, the only two firms that were selected for research based on a specific entrepreneurial venture or innovation both mentioned that execution can be a challenge to entrepreneurship. Both Mobil, who’s Speedpass is an example of an entrepreneurial product, and Shell, who’s GameChanger Process is an example of an entrepreneurial process, expressed that execution can be a daunting challenge. Mobil sided with NCR to identify buy-in within the firm to be another challenge. Maintaining the spirit and initiative entrepreneurship creates within a firm was a challenge mentioned by Kone and NCR. Giving potential entrepreneurial projects the time and other resources necessary to ensure their success could be an unexpected challenge according to Duke/Fluor Daniel and Dow explicitly although strategic leaders from other firms implicitly supported this conclusion. A third of the firms (3M, AT&T, Intel and Mobil) expressed the opinion that funding is a challenge.

Themes that came up only once regarding challenges faced in implementing an entrepreneurial venture of innovation were at times very specific to the structure of a certain company while at other times seemed to have a more universal nature about them. For instance communication between the U.S. subsidiary and the Japanese parent company was a noted challenge by Canon that is very specific to the structure of that company that none of the other firms interviewed shared. In comparison Duke/Fluor Daniel was the only firm to mention the challenge of maintaining credibility even though that challenge has a more universal tone to it. AT&T discussed the challenge of monitoring the number of small entrepreneurial projects going on simultaneously to receive the most promising result. 3M touched on the lack of funding while AT&T pointed to the challenge of controlling cost.

For all of the firm's focus on the future only Duke/Fluor Daniel noted the challenge of thinking about the whole life span of the entrepreneurial process. Interestingly Xerox was the only firm to mention struggling with the challenge of the "speed to marketplace" due to the large number of "competent" competitors the firm has in its industry even though other firms from this study are in the same or a similar industry as Xerox (Xerox, 2002). Mobil brought up another more universally attributable dilemma with entrepreneurship in larger organizations; a small group develops an entrepreneurial concept but a different group implements or executes so the first group has to convince the second group that the product is a worthwhile idea. Dow noted that there is no "generic" answer to the question of challenges faced by firms attempting to implement the entrepreneurial mindset, and that "Innovation is a full-time job" (Dow,

2002). According to the strategic leader at Dow, “If you are trying to innovate with part-timers, you don’t understand the issue” (Dow, 2002).

Qualitative Responses to Q23

Describe the barriers that had to be overcome to accomplish the challenge

Patterns that Emerged:

As was mentioned previously in this chapter, Q22 and Q23 had many similarities in the responses these two questions received. When the strategic leaders described the barriers that had to be overcome to accomplish the challenge of implementing entrepreneurship half of the firms (AT&T, Duke/Fluor Daniel, Dow, Intel, Mobil, and Shell) mentioned that buy in was a barrier that their firms had experienced. In this case buy in referred to individuals within the firm such as employees as well as those outside of the firm such as stockholders. AT&T, Duke/Fluor Daniel, Dow, NCR and Xerox all cited the competition for resources as another barrier. Frequently this competition is between small entrepreneurial projects and big projects that entail a more familiar concept.

In a similar way, Duke/Fluor Daniel and NCR specified that one of the resources that can be a limiting factor is the resource of time. It can be quite challenging to find the time to make a prospective project or process work. Duke/Flour Daniel’s strategic leader stated that, “...people tend to put entrepreneurial thought in the ‘too hard basket.’ You know its more work to think through it and go through all the regimen that is required to qualify it as something you want to do, and with the busyness of everyone’s schedule...it does not get the attention it may deserve” (Duke/Fluor Daniel, 2002). These comments

also support the assertion by AT&T, Intel and Shell that defining the new process or product can be a major barrier to implementing entrepreneurship within an organization.

For Canon, Duke/Fluor Daniel, Intel, Mobil and Shell communication was a potential barrier worth mentioning. The need for communication might be within an organization, such as the communication necessary within the ranks of Shell to make the GameChanger process a success, or it might be outside of the organization, like Mobil's struggle to communicate to the firm's appreciation for the business that their repeat customers give to Mobil. The Speedpass is one of the ways that Mobil has chosen to communicate with its customers. The product is in response to needs expressed by the customers such as speed and convenience and by attempting to address those customer needs head on Mobil has made a commitment to do their part to listen to their customers. Here Mobil exemplifies listening as one of the fundamental elements of communication.

Risk and implementing risk management were other barriers faced by Duke/Fluor Daniel, Dow and GE Capital. While other firms noted that cultural differences could be massive barriers most likely due to the fact that Canon and Kone were the only two firms included in this research effort that have headquarters outside of the U.S. For Kone the shock of being the first Finnish company to go public had ramifications on who the firm could look to as an example of how to become a global firm. Canon is located in Japan with a U.S. subsidiary and that situation presents a host of other complications. Canon's strategic leader stated that some of the most extensive barriers that the U.S. subsidiary have experienced had to do with getting headquarters to listen and respond to the needs of the subsidiaries rather than just "putting out the product" (Canon, 2002). The cultural challenges mentioned by the international firms included language barriers.

For AT&T and GE Capital the cultural barriers that the strategic leaders referenced had more to do with the culture within the company than the way the company interacts with its international subsidiaries. The strategic leader at GE Capital specifically mentioned the well known impact that having a new leader, Jack Welch, had on the culture at the firm (GE Capital, 2002).

While many of the firms implicitly referenced the difficulty in properly assessing and addressing customer needs, both 3M and Intel made it clear that this can be a barrier to entrepreneurship in their firms. 3M noted that finding out “what customers need” and then developing products to meet those needs can challenge the firm’s creative thinking skills (3M, 2002). Intel concurred with this sentiment but added that part of the concern is the need to create a product that people want to buy.

Qualitative Responses to Q24

Would you say the organization as it existed at the time the venture kicked off was well designed for the venture—or were changes to the organization design required?

Patterns that Emerged:

Over half of the firms interviewed (AT&T, Canon, Dow, Duke/Fluor Daniel, Intel, Kone and Shell) stated that their firms had changed a great deal since the inception of the entrepreneurial venture. Yet, there were a variety of circumstances that combined to explain the changes. For instance Canon and Duke/Fluor Daniel stated that the changes were needed for better communication within the firm, while 3M mentioned the structural changes necessary to move from a fledging mining company of the past to a globally recognized R&D company of the future. Dow referred to their firm being in a

“constant state of flux” and GE Capital mentioned that the members of their firm have felt that way too at times (Dow, 2002).

Sometimes changes will only affect a portion of the firm, especially in larger organizations. Shell concurred that this has been true from their experiences. For instance Shell recently made many changes in the Shell Chemical Department. One of the results of these changes was that a great deal of nurturing was required after a “somewhat traumatic divestiture exercise” (Shell, 2002). Other results mentioned included the need for more training (Duke/Fluor Daniel, 2002) and the need to realign roles/responsibilities to match new initiatives (NCR) after the changes were made to the organizational design to accommodate new entrepreneurial ideas. While some firms worked within their existing organization to implement entrepreneurship other firms such as AT&T and Xerox also created separate venture funds, at least in part, to address specific entrepreneurial interests that were not necessarily within the core competencies of these firms.

Qualitative Responses to Q25

What were the expected benefits that compelled your company to strive to be more entrepreneurial?

Patterns that Emerged:

More than half of the firms (3M, AT&T, Canon, GE Capital, Intel, Kone, and Xerox) stated that profitability and increased value were among the expected benefits that compelled their firm to be more entrepreneurial. Intel summed up the reason for this profit focus by saying that the “. . . biggest motivation is survival” (Intel, 2002). By

continuing a trend towards increased profit the firms have a better chance to extend the healthy existence of their firm and that is understandably very desirable to them.

On the other hand Duke/Fluor Daniel and Xerox both hoped that moving to a more entrepreneurial focus would help their firms to balance risk. Canon, Intel and Mobil saw a potential method for increasing the satisfaction of their customers with the way this firm serve them. 3M, GE Capital, Shell and Xerox all hoped to use this as a means to promote growth in their firms. This final response was similar to answers given to Q1 regarding what caused firms to attempt to be entrepreneurial in the first place.

Quantitative Results

In addition to the qualitative data gathered, quantitative data, in the form of numerical assessment surveys, was also gathered from each of the strategic leaders. Each of the strategic leaders was asked to answer forty-two numerical assessment questions. All of the participants, except for Intel, completed the entire survey. Intel answered only a portion of the quantitative questions. Most of the strategic leaders responded to the numerical questions via email although a few opted to answer these questions over the phone. All of the numerical assessment questions are listed in **Appendix P** in the appendices. **Appendix P** indicates the mean and standard deviation for each question as well as the original directions that the participants were given. The highlights of **Appendix P** are explained in more detail below.

Means: Highs and Lows

The numerical assessment questions were on a scale of 1 to 5 with five indicating that the strategic leader strongly agreed with the statement. The highest mean response

was on Q2.4 (*“In gathering support for innovative ventures internally, we tend to focus on creation of commitment from needed supporters rather than pursuing rational arguments to justify the project”*). The mean response for this question was 4.10 which is notable since many of the firms mentioned in their qualitative responses that buy-in is a key element of successfully implementing entrepreneurship. It is important to note that while 4.10 is the highest mean for any of the questions, most of the questions (30/42) had a mean score of 3.0 or higher. This is to be expected since these firms were specifically chosen for the success with entrepreneurship. It is understandable that strategic leaders would respond more positively to questions related to the experiences their firms have had with entrepreneurship.

The lowest mean was 1.82 on A11 (*“It is difficult to form teams in our organization”*). Since all of the firms explicitly or implicitly mentioned the value of team work within their firm it is understandable that the strategic leaders disagreed with this statement. According to firms such as Duke/Flour Daniel and Shell it is largely the fact that teamwork is fostered within the organization that has been so critical to their success with entrepreneurship.

Patterns that Emerged:

Not surprisingly, the majority of the survey questions received a maximum score of five (38/42). This was expected due to the fact that all the firms included in the research were previously identified to have had success with entrepreneurship. High maximum scores on questions such as *“We are increasingly improving our efficiency”* (Q2.8) or *“There is top management sponsorship of innovative pursuits”* (Q3) were in keeping with the initial expectations of the researcher.

On the other hand, it was surprising that a majority of the minimum scores for each question (26/42) had a minimum score of one. In over half of the cases (62%) this minimum score of one was indicated by only one firm, yet it was still unexpected to have some firms strongly disagree with elements of how their firm implemented entrepreneurship. For instance, only GE Capital strongly disagreed with the statement that “*People are not rigidly held to plan but are encouraged to adapt to unfolding circumstances*” (Q2.1). 3M was the only firm to state that they do not take the approach where funding is postponed through investments and expenditures for as long as possible (Q1.6).

While there were a large number of minimum scores of one in the qualitative section it is important to note some specific patterns. There were six instances where Canon was the only firm to strongly disagree with the statement and their peers by responding with a score of one. Canon was an outlier when it came to the firm’s experiences with entrepreneurship. Based on the comments made by the strategic leader during the guided interview it is quite possible that the quantitative answers that Canon gave differ because of the firm’s structure. The strategic leader who was interviewed works in the U.S. subsidiary of the Japanese based Canon and as such was answering all of the questions based on their experiences at Canon USA. Questions such as “*New people that come on board are easily assimilated and feel that they can cope very early on*” (Q3.4) or “*There is a firm policy to frequently revisit the basic assumptions of the business and question their future validity*” (Q4.1) may not apply as much for a subsidiary organization as for the firm headquarters.

Dow was another outlier. There were a total of five times that Dow disagreed with its peers and stated that the question did not apply to their experiences with entrepreneurship. While the instances where Canon disagreed with its peers may be attributed to the fact that the strategic leader was using Canon USA as a reference point there is no such explanation for Dow's minority opinion. Conversely, Dow strongly disagreed with statements such as; "*Our attention is focused primarily on external rather than internal issues*" (Q2.9), "*Our communications are primarily with outsiders rather than internal*" (Q2.10), and "*Top management has experience with innovation*" (Q2). It may be that although Dow has been recognized for its success with entrepreneurship, other unresolved internal issues are altering the firm's perception of its experiences so that Dow's strategic leader disagreed with his peers a number of times.

Chapter Summary

Now that a better understanding about each of the firms' backgrounds and how those backgrounds relate to the firm's implementation of entrepreneurship has been gained, and a thorough presentation of both the qualitative and quantitative survey results was made. It is time to move on to a discussion, in chapter five, on the analysis of findings, the limitations to the research, and recommendations for future study in this area.

V. Analysis

Chapter Overview

This chapter begins with a discussion of the results described in chapter four. The patterns that emerged from the quantitative data are explained. In the analysis section the emergent patterns are divided into four groupings which are explained in greater detail. An explanation of the limitations of the study and lessons learned while proceeding through the process of writing this thesis are also detailed. An explanation is given on how the research questions and problem statement laid out in chapter 1 were addressed throughout this thesis. Finally the chapter ends with recommendations for future studies on this topic and a sketch of how this research can be applied to DoD organizations.

Analysis

Content analysis and pattern matching of the comparative case studies resulted in four groups of emergent patterns: 1) initiators and antecedents; 2) organizational practices; 3) barriers to implementation and 4) outcomes. The data was independently coded. This initial coding resulted in an 85% agreement where differences were resolved through a discussion. Each of these areas is discussed below and depicted graphically in a relational model in **Figure 1**.

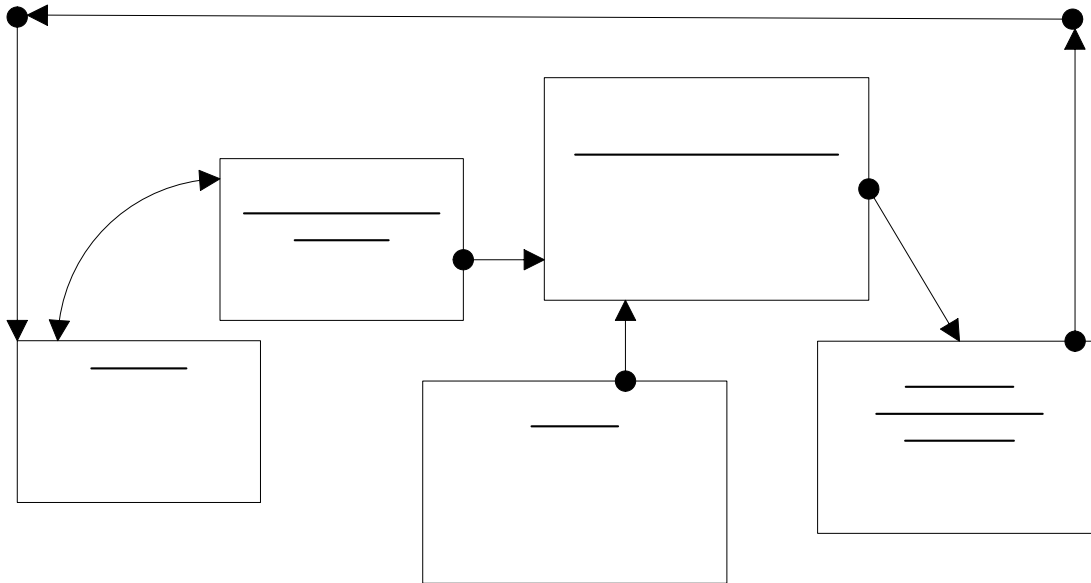

Figure 1. An integrated model of the corporate entrepreneurial concept (Reed, Smith & Holt, 2003)

Initiators

The strategic leaders were asked to describe what caused the firm to pursue entrepreneurial ventures (Q21) and the key challenges that the organization faced at the time (Q22). Two primary patterns emerged: internal initiators and external initiators. Among the antecedents or initiators internal to the firm were the direction of boards of directors, the realization of untapped potential, and the desire for cultural consistency. For example at Duke/Fluor Daniel, previous serendipitous innovative experiences indicated that the potential to be entrepreneurial existed within the firm, so they instituted a more formal process to capture that mindset within the organization. At AT&T they sought to be less “process bound” and pursued an entrepreneurial mindset as a means of relieving process constraints.

Initiators
What drove the
decision to become
entrepreneurial?
 Consider internal & external
 factors

Strate
D
 How do
 and inte

Initiators external to the firm included the emergence of a dynamic marketplace and the desire to develop new methods to achieve greater market share. Mobil became aware that they needed to differentiate themselves from their competitors and one of the ways they felt they could do this was to offer speedier and more convenient service to their customers. Their competencies at the time focused on fuel production and delivery, which were directed at a commoditized product (gasoline). In order to develop products and services which met emerging customer needs, they implemented entrepreneurial processes—the result of which was the Speedpass customer identification card.

Organizational Practices

Strategic leaders responding to the internal and external initiators described above all sought to instill an entrepreneurial mindset by modifying existing organizational practices, or by creating new ones. Three patterns of organizational practices emerged: organizational structure; reward systems; and, human resource practices.

Implementation via organizational structure changes was illustrated by NCR's realignment of roles and responsibilities with emerging initiatives. Duke/Fluor Daniel established a “strategic initiator group” that became a focal point for entrepreneurial activity.

The importance of developing a new reward system was highlighted by the participants, quantitatively, participants strongly agreed (3.6 out of a maximum of 5) with the statement “additional rewards/compensation exist for successful innovation” (Q16). While participants did not expand specifically on this subject in the guided interview many such as Shell indicated that reward systems do exist in their firm. Rewards can include monetary bonuses for entrepreneurial suggestions or intangible rewards such as

acknowledgments for an individual contribution to a product or technology that later was patented. 3M, AT&T, and Xerox were all firms where the strategic leaders mentioned the pride taken in the number of patents the firm has been able to gain. The rate of innovation is not just a source of pride for the firm but also an intangible reward for the employees who participated in bringing an innovation to the level of patenting.

Processes for ensuring the right human resources are in place and utilized optimally were also cited as being important. Participants strongly disagreed (1.8 out of 5) with the statement “it is difficult to form teams in our organization” (Q11). In addition small and experimental projects were highly supported (4.0 out of 5) (Q7); people got second chances after mistakes (4.0 out of 5) (Q8); people working on new ventures made decisions based on a few core values rather than large numbers of rules (3.7 out of 5) (Q3.2) and people were not rigidly held to plan, but were encouraged to adapt to unfolding circumstances (3.5 out of 5) (Q2.1). Nearly all of the strategic leaders mentioned the effective use of small teams to be detrimental to their firm’s successful implementation of the entrepreneurial mindset.

Barriers

Strategic leaders encountered a variety of barriers to implementation along the way, both organizational barriers and individual barriers. Three primary organizational barrier patterns emerged in our analysis: 1) the goals of the organization; 2) the availability of resources for the new processes; and 3) the degree to which the new process clashed with the existing organizational culture.

Goals of the organization may conflict with individual goals, and the goals of other parts of the organization. Mobil was very successful in developing the Speedpass,

yet had difficulty in implementing it when local station owners resisted the infrastructure investment. Only after persistent communication detailing the importance of an “all or none” strategy was the roll out of the Speedpass successful.

In the interviews, a number of different resources were mentioned. Each of the firms has grappled with how much time, money and people power to devote to entrepreneurial pursuits. Financial resources are always limited, and this pattern was clearly evident in our research. AT&T found that large, familiar projects would often receive resources before small, unfamiliar internal ventures. Time is also a precious resource, and our participants indicated that identifying human resources to participate in creative innovation was often difficult to justify when outcomes were not well defined. Xerox seeks to find a balance between supporting “reliable business options” and options that will “transform your business.”

In emerging global firms, the impact of cultural differences between units operating across national borders was highlighted by our participants. Canon for example faces the on-going challenge of “blending” Japanese employee loyalty with the profitability focus of their American counterparts. Kone on the other hand mentioned how the formation of the European Union has aided the firm in overcoming some of the cultural barriers the firm had originally faced across international borders, by standardizing legislation and products across the Union.

Patterns emerged that indicated the abilities of the individuals and the degree of cynicism of organizational members were important individual barriers to implementation. While Duke/Fluor Daniel “knew they had the capability to be entrepreneurial” they were concerned that they might not be able to get the “right people

at the right place at the right time.” Similarly, other organizations such as 3M, GE Capital and Canon talked about the seemingly constant change that takes place in their organizations. This idea of constant change can be a barrier to the implementation of the entrepreneurial mindset since it may feed the cynical idea that no change is good enough to be permanent. Organization history also presents a challenge to firms. If there has been a history of repeated “magic bullet” initiatives (e.g. Total Quality, Management by Objectives, etc.) then employees may be inclined to view entrepreneurial innovation as the latest fad. This was the case at NCR and Shell where strategic leaders continue to struggle to convince some organizational members that entrepreneurial venturing is the “right way to go.” Quantitatively participants strongly agreed that they were able to identify places where inertia or disinterest was likely to impede progress (3.6 out of 5) (Q2.5)

Outcomes

The outcomes that were either expected or achieved included increased profit; increased growth, reduction of risk and increased customer satisfaction. Of these outcomes reduction of risk and increased customer (i.e. war fighter) satisfaction are most applicable to DoD organizations. There was no ambiguity in our findings relative to profitability being the primary driver for implementing the entrepreneurial mindset. The strategic leaders also strongly agreed that they were increasingly improving their efficiency since implementing the new mindset (4.0 out of 5) (Q 2.8). In addition firm growth emerged as an identifiable pattern. Xerox specifically sought to enter fast-growing market segments, and saw entrepreneurial activity as the means of achieving that goal. While participants such as GE Capital and Mobil did mention risk reduction as

motivating variable, the focus of all the participants was almost exclusively on the potential upside, with very little commentary overall regarding the potential risk of the processes. In fact only Duke/Fluor Daniel mentioned the potential for a firm to end up in bankruptcy for improperly implementing entrepreneurship. Interestingly, participants did not agree that a significant percentage of their existing business would become obsolete each year (2.4 out of 5) (Q4.2). This may be due to the large size of the firms, and to a degree misplaced confidence that their size makes them more secure than smaller firms.

Discussion of Results

Both qualitative and quantitative data were combined from a select group of strategic leaders to identify the antecedents to the implementation of an entrepreneurial mindset, the barriers to implementation, and the outcomes of implementation. As the data was analyzed, a conceptual model emerged that shed some light on these issues, but also helped explain the process organizations go through as they initiate and implement an entrepreneurial mindset. The central feature of the model was the strategic leaders' decision to embrace and diffuse this mindset throughout the organization. This decision appeared to be influenced by factors both external and internal to the organization. Once a decision is made, participants suggested that leaders use specific organizational practices to encourage the set of entrepreneurial behaviors required of individuals (i.e., actively seeking new opportunities, focusing on adaptive execution, and incorporating people inside and outside of the organization in their quest to achieve successful implementation). Participants went on to say that there was a set of organizational- and individual-level barriers that might influence the extent to which these practices would

effectively encourage the desired behaviors and prevent the realization of the desired outcomes.

Looking at a few more model specifics, both external and internal initiators referred to existing conditions such as competitive threats and opportunities that should be considered as any leader develops a strategic plan. Based on the environmental analysis done by leaders, specific organizational practices were encouraged, encompassing the systems that facilitate and diffuse corporate entrepreneurship throughout the organization. While several practices are available to help leaders foster the entrepreneurial environment, our participants noted the importance of aligning the organization's structure, rewards and incentives, human resource management techniques, and operational processes. Collectively, these systems were said to encourage the individual behaviors that are needed to fulfill the firm's entrepreneurial goals while simultaneously helping individuals fulfill their own. As noted, organizational and individual barriers influenced the extent to which these practices encouraged the desired behaviors and facilitated the subsequent outcomes (i.e., profit, growth, customer satisfaction). Barriers are both organizational in nature (i.e., culture, history) and individual (i.e., ability, cynical attitudes).

Given this model, the larger question of interest focused on how the patterns observed in these large, private-sector firms were consistent with those in public organizations, particularly DoD. Not surprisingly, the senior leadership of the DoD has recognized the initiators—triggering a movement toward an entrepreneurial mindset. In particular, the leadership has recognized a shift in the operational environment (i.e., dynamic marketplace). Additionally, leaders have noted that innovations at all levels are

necessary if its forces are to maintain their superiority in anticipated conflicts (i.e., acquire market share). As a result, the leadership appears to have made the crucial decision to pursue an entrepreneurial mindset; that is, Secretary Rumsfeld has explicitly called for the DoD to become more creative, encouraging its members to be proactive and innovative.

Limitations

Just as the participants all mentioned the barrier of limited resources so too was the availability of resources such as time a hindrance in thesis research effort. With time to only interview a handful of entrepreneurially successful firms, it was impossible to take into account all of the diversity of the firms represented in the study. Some participants were more familiar and comfortable discussing entrepreneurship in their firm and these participants tended to expand more in each of their answers. Also the questions were geared towards a specific innovative venture that the firm had undertaken. For firms such as Mobil with its Speedpass venture it was easier to relate those questions to a specific innovation rather than trying to relate it to the processes of the entire organization.

One of the limitations is the ability of the individual researcher to discern what the strategic leader meant when he used certain terms. While most of the strategic leaders are very familiar with the common terminology of the study of entrepreneurship some were not as familiar. Every precaution is taken to accurately depict the firm and what is said but when attempting to identify trends in the experiences of the different firms there is always the possibility that a unique element of one firm's experiences may be lost in the effort to find common themes in their various experiences. This is where the

importance of the literature review and comparing the results gathered to the results gathered by other researchers in similar experiments become important.

Due to the lengthy nature of most of the phone interviews a professional third party was chosen to transcribe the phone interview tapes into Word documents. While this was a great advantage for issues of speed it was in some ways a disadvantage since the transcriber was not familiar with the subject matter there were some minor discrepancies found in many of the transcripts. Most of these discrepancies involved the transcriber not being able to hear or understand some of the terminology that the strategic leaders used. For instance the term “GameChanger” was unfamiliar to the transcriber and was incorrectly transcribed at first. Due to this potential for error each of the interviewers was proofread by two different researchers familiar with the subject matter to ensure accurate transcription to the greatest extent possible.

While some interviews went very smoothly others were more of a challenge. Strategic leaders are busy and because of this can be hard to contact in order to interview them. Some of the strategic leaders were eager to talk about entrepreneurship in their firm and they required little prompting to give examples and lessons their firm has learned in the firm’s quest to be entrepreneurial. In these interviews it was common for the interviewer to ask follow up or clarification questions about responses that the strategic leader had given to the qualitative questions. Although these follow up questions added a more clear understanding of the idea the strategic leader was trying to get across, they made it more difficult to standardize the interviews. This was especially true if the clarifying question lead off onto a tangent, but equally relevant subject regarding entrepreneurship in the firm.

A few of the strategic leaders requested a copy of the questions before they would agree to be interviewed. Since this was not the case for all of the interviewees some people had more time to prepare their responses to the qualitative questions than other people, although none of the strategic leaders seemed to indicate a desire for more time to prepare their answers.

When going through the process of pattern matching and analyzing the entire transcript of each of the interviews it became evident that just because some of the strategic leaders did not specifically mention a characteristic that other strategic leaders did, was not an indication that, that situation was not common among the firms. In other words, some strategic leaders may have been more concerned with one aspect of their business that applied to the other firms that were surveyed but because of which strategic leaders were interviewed in each of the firms those sentiments may not have come through as clearly. For instance six of the firms mentioned buy in was a barrier for their firm when attempting to implement the entrepreneurial mindset. This data is not meant to imply that the other six did not experience a similar situation but could possibly be due in part to who was interviewed within the firm and their personal experiences with their firm's entrepreneurial effort.

When compiling data for chapter 4, the process of pattern matching lended itself to gleaning information from the entire transcript that might apply to a specific question. For instance some of the strategic leaders were asked if they had any parting thoughts at the end of their interviews. While their responses did not directly correlate to the specific qualitative questions that had been asked if their response applied it was added to the corresponding response section of the pattern matching documents.

Few people mentioned the downsides of the entrepreneurial approach. All the strategic leaders seemed to have a very positive view of the potential success that the entrepreneurial mindset could offer their firms. Relatively little thought seemed to be expended on the potential risk elements of this approach. Only a handful of the strategic leaders mentioned the possible downsides and those that did spoke mostly of the general need for risk management. Part of the reason for this may lie in what position the strategic leader holds in the firm. Even the most well prepared person is still only one person in a large firm. They can really only offer a glimpse of what is taking place in that firm not a full view of the dynamics within the firm of implementing and maintaining the entrepreneurial mindset. It is possible that the person who deals with entrepreneurship in these firms is not the same person who deals with balancing risk in that firm so that the entrepreneurially focused strategic leaders with whom I spoke were less concerned with issues of risk than others from that firm might be if interviewed.

Another limitation to this method of research is the human element. Due to the very nature of a phone interview and the randomness of people (both interviewer and interviewee) the interviews are as standard as possible. It should be noted that while this lack of standardization might be a major limitation in many fields of research since this research effort is exploratory in nature the desire to gain a full understanding outweighed the desire to standardize every interview down to the last detail. The qualitative questions can be seen more as a guide than a checklist.

Research Questions & Problem Statement

In response to the research questions laid out in chapter one the answer that has

emerged over the course of this research is largely, “it depends.” Just as the large private sector firms that were interviewed had a wide range of experiences with entrepreneurship so too can DoD organizations expect to have a myriad of layers of experience. The data gathered from the twelve firms does in fact support the idea that if DoD organizations were to strive to be more entrepreneurial they will be able to achieve their goal of transforming themselves to better serve the end customer (i.e. the war fighter) with what the customer needs before they need it. All of the firms interviewed were large and bureaucratic organizations in their own ways. Each of these firms has had some level of success with implementing the entrepreneurial mindset in their organization. These twelve firms are proof that regardless of differences in mission scope, DoD organizations have the opportunity to obtain similar results if they can adapt entrepreneurial practices and thinking patterns that fit their unique mission.

In terms of the problem statement chapter 4 addressed most of the problems outlined in chapter one. In chapter 4 patterns in similarities between successful entrepreneurial activities in the private sector were identified for potential public sector use in the future. Additionally, new means of identifying entrepreneurial success in a way that is meaningful to public sector organizations was also outlined. The only portion of the problem statement that was not fully addressed was a detailed explanation of how the identified private sector patterns of entrepreneurial success can be applied to public sector organizations such as DoD. As is explained in the recommendations section to follow the question of how to apply the results culled from this research is an area that requires more attention than can properly be given to this subject in this modest thesis effort. This is not to imply that this topic is not of the greatest of importance, but merely

to say that to answer this question fully will need to be addressed by further research in the future.

Recommendations

While the model suggests that the decision to pursue the entrepreneurial mindset is crucial, subsequent steps are needed. First, it appeared equally important to follow-up a leadership decision by aligning appropriate practices that further facilitate the mindset. The anecdotal evidence suggested that the DoD leadership has recognized this suggesting several practice modifications, namely, revisions to selection practices, compensation systems, and structures. Still, it is not enough to use practices that foster an entrepreneurial mindset, steps must be taken to ensure that these practices encourage organizational members to *utilize* their innovative skills and abilities to the organization's (and their) benefit. Thus, the application and demonstration of innovative skills and abilities is at the very heart of corporate entrepreneurship.

It is in this final arena where considerable work must be done in the public sector. To gain a complete understanding of whether government organizations can employ the techniques used, further work should explore the framework in which both types of organizations operate. For instance, participants said that it is important for leaders to use human resource management practices to facilitate entrepreneurship. While all leaders (of both public and private sector organizations) introduce innovations within the existing framework of their organizations, leaders within public organizations may have less discretion to alter these practices than their civilian counterparts because of constraints imposed by outside agencies.

One of the ways that Secretary Rumsfield and others encourage entrepreneurship in DoD organizations is to tell us to innovate and then give leaders the opportunity to push as hard as they can to change their organization and its processes for the better. While there may not be a formal process mandating specifically how a unit commander must lead their organization to be more entrepreneurial; this can also be seen as a benefit since the individual organization has leeway to implement their own entrepreneurial plan that best addresses the needs of their organization. The recent changes in AFOTEC has seen are an example of how implementing the entrepreneurial mindset in DoD organizations in this manner can be successful.

While the study has suggested a process model that could be used in subsequent efforts to explore diffusion of an entrepreneurial mindset, a number of concerns warrant note. First, the model is by no means comprehensive. Only a select group of industry leaders at the top of their organizations were interviewed. While these people were crucial to understanding the entrepreneurial mindset, more insight may have been gained into what these leaders think *has happened* in their organizations rather than what *has actually happened* in their organizations. Thus, I would recommend that a more representative cross-section of employees be interviewed in subsequent studies.

Additionally, I suggest that researchers take an individual-level focus in subsequent studies. I believe this is necessary because an entrepreneurial mindset appears to be carried out by individuals within organizations. That is, business firms by themselves do nothing—even the most collective activities (such as corporate entrepreneurship) that take place within organizations are often the aggregation of the

activities of individual organizational members; therefore, organizations will be innovative, proactive, take risks through the actions of their members.

This paper began as a humble attempt to explore the implementation of the entrepreneurial mindset in large private sector organizations to learn lessons that might be applied to the public sector. As with many endeavors utilizing qualitative techniques, the data leads down a slightly different path, suggesting a model that explains the process that organizations go through as they try to diffuse an entrepreneurial mindset throughout. This model is by no means complete; however, the hope is that it serves as a springboard to future quantitative studies that refine and more accurately depict the process in both private and public organizations.

Appendix A: 3M Interview Transcript

Interviewer: Captain Jason Whittle

Date: 21 November 2002

Jason	Good morning. This is Captain Jason Whittle. How are you?
3M	Good morning! I'm just excellent, how are you?
Jason	I'm good. You got about 30 minutes? Again, just real quick answers if that is all you can give me.
3M	Let's try. Was the book helpful?
Jason	Yes, and it is actually really good reading too. I am enjoying that.
3M	Well you were asking a lot about the history, and that is just full of it.
Jason	I have kind of modified my methodology, so what I am going to do is combine your interview questions, or draw a distinction between what I got from interviews and what I got from the literature. It is going to be just as helpful. I just had to tweak things a little bit.

Q1:	What caused the company to pursue entrepreneurial ventures or new innovations?
R1:	It's the story in the book, you know, they were trying to be a mining company up in northern Minnesota, and they were not finding the material they were looking for, which was corundum, so they decided that they needed to develop a laboratory and start developing new products.
Q2:	Describe the key challenge that was faced regarding this venture or innovation.
R2:	It was probably lack of money.
Q3:	That is clear in the book as well. Describe the barriers that had to be overcome to accomplish the challenge.
R3:	It was probably trying to figure out what customers needed, and the stories are around going out to customers and trying to find out what their needs are, then come back to the laboratory and see if they could develop products that met those needs.
Q4:	Would you say the organization as it existed at the time the venture kicked off was well designed for the venture, or were changes to the organization design required?
R4:	Totally changed. It was designed to be a mining company and it turned into an R&D company.
Q5:	What were the expected benefits that compelled your company to strive to be more entrepreneurial?
R5:	The expected benefits would be growth, sales, and you know, profits.
Q6:	Does your organization have a reserve of human resources that are available to pursue new opportunities on short notice, should they arise? Then we talked about this a little before when I went fishing—if a new opportunity comes up, you mentioned---
R6:	We shift those resources around until we figure out what we can stop doing, and move people to the new opportunity.
Q8:	Are these people in all sorts of jobs, including support type jobs?
R8:	Yes, all over the company.

Q9:	Who do they report to, and you mentioned it was decentralized?
R9:	Yes. There are different divisions, different staff groups.
Jason	Just so I am clear, each division would have its own small finance group or contracting group, or a personnel group?
3M:	Yes.
Q11	Can you provide examples of the types of goals these resources, I guess the people, are aimed at achieving?
R11:	It could be a new product launch. It might be a process improvement of some kind, might be aimed at a new market, like right now with 9-11, and everything that is going on in the world, the security market is falling. So we have a team aimed at that, for example.
Jason	Did that come from recognizing a need?
3M	Yes.
Jason	The firms always worked this way, which is evident from the book, the reprioritizing of the human resources?
3M	Yes. Since I've been with the company I have watched us get out of—again, we were very big in the copying business and we got out of that. We were in the facsimile business and we got out of that. So the company is constantly evolving and changing itself.
Jason	Can you explain the 15% rule a little more?
3M	Yes. It is really simple. If I have an idea for a new product or something new, I am allowed to use 15% of my time to work on it. What it really means is, it doesn't mean like at 2:30 in the afternoon I stop working and starting working on my 15%. It is really more of permissions slip, that my boss won't say no if I'm trying to push some new idea.
Jason	How do other resources within the organization fit into that? The book talks about the 3M resources being available for people to be innovative, even during that 15%.
3M	Yes, but what you do is go around, and you know, I'd come to you and say I've got an idea Jason, would you be interested in working on it with me? If it is a compelling enough idea, people will want to

	help you.
Jason	What about things like resources such as raw materials that cost money?
3M:	You sort of beg, borrow, and steal however you can. There are little grants and stuff that are available in the company, but it is pretty much, you know, what can you scrape together?
Jason	You talked earlier about not hiring extra people. Do you want to elaborate at all on that? So you always get things in-house, I guess it's just the reprioritization?
3M	Yes. Really the key is trying to figure out what it is you can stop doing? What can you say no to, so that you can work on a new priority? It is a constant process of asking yourself, am I working on the most important things.
Q17	This question is talking about the stakeholders balking at this; we call it kind of inefficiency, but the stop and go mentality of R&D? To clarify that, did stakeholders balk at perceived inefficiency?
R17	Yes. It can look messy, so it is not sort of the model of mechanized efficiency, and you've got to have a high tolerance for human feelings and mistakes and that sort of thing. But it really boils down to do you trust people to be doing the right thing? That is what 3M's original CEO really established. There is probably a quote in there somewhere from Mr. McKnight about people will eventually want to do the right thing, so management has to be very tolerant of their mistakes. That's really part of the culture.
Jason	How did the firm create creative capacity, and where did the excess capacity come from, and I kind of bated you with talking about BPR and contracted experts, which we've already discussed, and you talked about the mind-set within the company—the flexible mind-set, and you touched on that just a second ago. Is there anything more you want to elaborate on?
3M:	Not that I can think of.
Q19	How did, or does the firm determine the optimum amount of the creative capacity, or in your case, the reprioritization? You know, when you were talking about it being a constant process of reprioritizing, how do you determine that?
R19:	I guess it is by how well the company is growing. Right now our

	growth has slowed, so there is lots of effort on what can we do to get new products coming out of the laboratory?
Jason	How often does it change? You talked about it being constant; anything more you would like to elaborate on that?
3M:	It is kind of a constant process of how are we doing, what new is coming, and if it is not, what can we do to fix it?
Jason	And the measures that determine----?
3M:	Well I think the latest version is 40% new products in four years. So 40% of what we're selling, we weren't selling four years ago.
Q21	This question might be kind of silly in light of the reprioritization we were talking about, but what has been the primary outcome resulting from this shuffling of resources?
R21:	It is really the whole company, \$17,000,000 in sales. How's that?
Q22	That sounds good. The last question is what are, or were some attempts at this reprioritization or reshuffling that had failed, and you mentioned that failure happens and is expected? Is there anything more that you want to elaborate on?
R22	Well, if you're turning over your product max, you know 60%, or 40% every four years, there's a lot of failure in there, so there are tons of stories around the company about different products that were tried and failed. Usually what happens is the technology or thinking that was developed then becomes part of something else. So failure is never really a failure, because you learn something that you can apply somewhere else.
Jason	That concludes the questions. Is there anything else you want to elaborate?
3M	Not really. I think the books really will give you the depth that you need for your report, but I think you have the general idea.
Jason	Yes. I got the book and I got your survey, so I think we're good to go for now. Thank you again for your help and have a good day.
3M	O.K. Take care.

Appendix B: AT&T Interview Transcript

Interviewer: Lieutenant Rochelle Smith

Date: 6 November 2002

Rochelle	I have 18 questions, and if there are some that don't apply, or you don't have answers for, please feel free to say you cannot answer that, or you do not have time.
AT&T	Could you just give me a little background as to what's the thesis of your thesis is?
Rochelle	My thesis is that what is going on in the entrepreneurship in the private sector, AT&T and other large private sector firms is something that DOD, Department of Defense organizations, like the Air Force, should be looking at because when we try to become more entrepreneurial, we might be able to use some of the examples. For instance, if you have one manager that is wonderful in entrepreneurship, and that's how AT&T became entrepreneurial, then that is something that the Air Force might need to do--get one person who knows a lot about entrepreneurship, and you'd think about it that way. So that's what we are looking for right now, kind of general ideas about how we can become more entrepreneurial as a force.
AT&T	O.K. I'm ready.
Q1	What caused your company to pursue entrepreneurial ventures or new innovations?
R1	Two or three things. First of all, obviously, we are a large company, and as in any company where you have large established clientele and a development practice in software development, or anything else like that, you could be pretty process-bound in some of the work that you do; therefore, for small quick things that you might want to get done, you may want to have a different path to pursue. So there is always trying to seek ways of having the small simpler ideas, have a quicker path to blossom, than going through the bigger process. That is what would cause any large company to decide that they want to try something a little bit entrepreneurial, and there are different ways of accomplishing that.
Q2:	What were some of the key challenges that your company faced regarding this venture or entrepreneurship in general?
R2	Like anything else, what you are trying to do is work a way, as I would say it---you want to let 1,000 flowers bloom, but you want to also make

	<p>sure that you are not planting a lot of weeds with them, or that you know how to cull out the flowers that you want to pick, once 1,000 of the bloom.</p> <p>The other thing that could happen quickly in a large company is that you could start a lot of small projects, but the numbers get pretty big pretty fast. If you don't know how to control that number, then the cost, even though you small amounts of dollars and people time, the multiplier could get pretty large pretty quickly. You could kind of lose the forest through the trees here.</p>
Q3	What barriers had to be overcome to accomplish the challenge?
R3	<p>The challenge, I would say, is how can you create a process that allows for quick ideas to flourish in an organization that is used to, and depends upon, large well-defined, maybe slower moving processes. The barriers that you would have are people who expect processes to work at a certain rate. There is the barrier of the general expectation that everything must follow the process, and there is the barrier that says where do you get the money from this thing?</p> <p>In other words, if the typical way of obtaining money in a corporation for a project is do a business case, do this, do that, everyone competes for the money, a small ill-defined, or not as well defined processes, will always find itself not being able to compete against the bigger projects, so the little tree always gets shaded out by the bigger ones.</p>
Q4:	So would you say that AT&T as it existed at the time that your entrepreneurial venture kicked off was well designed for that venture, or were changes to the organization design required?
R4	<p>When you say venture, I keep looking at lots of different things that we did that would be considered entrepreneurial, so let me define the ones that I am thinking about.</p> <p>(1) In AT&T labs we have a way of funding some types of development that eventually could get spun off into a separate company, or developing intellectual property that could be sold to another company.</p> <p>(2) Then there was a time that and this was several years ago, prior to the spin of Lucent Technologies, where we actually created a Venture Fund. We funded those ventures through something called AT&T ventures funding.</p>
Q5:	What were the expected benefits that compelled AT&T to strive to be

	more entrepreneurial?
R5	Expected benefits would be that a technology that might be useful, that would not normally fit into the large business case process, could be allowed a chance to blossom. Some smaller or off the beaten path technologies that did not have a direct impact on a particular business project we were working on, would be allowed to blossom and be given a chance to grow, and potentially make some money for the corporation one way or another.
Rochelle:	You had mentioned the AT&T Venture Fund. Prior to that fund, was there someone or an organization within AT&T that watched over entrepreneurial ideas?
AT&T	<p>The fund that I remember was created probably in the 1992, 93, 94, time frame. It was at the time run by a person named Dick Bodman, I think, when we eventually spun that fund off. It was a venture fund that outside people could contribute to as well as AT&T, and we put funding into it and made it a typical venture-cap type or worth where they put seed money into ventures. Prior to that what you had was in Bell Laboratories, which as you know, is not affiliated with AT&T anymore, but is in Lucent Bell Laboratories.</p> <p>AT&T Bell Laboratories is the research and development on AT&T when it was the Bell System, and when it was AT&T after it spun off the Bell operating companies between 1982 and 1996. When we spun off Lucent Technologies, AT&T Bell Laboratories went with it. AT&T, the remaining AT&T—the company you are talking to now—also took some of those people and created AT&T Laboratories. The difference in the name is there is no Bell Labs in there. As a matter of fact, Bell Laboratories was the only time that the AT&T Company was allowed to use the term Bell after 1982. Think of prior to 1982 you had the Bell System, and that was AT&T, long distance; it was all the Bell operating companies: New York Bell, Pacific Bell, Southwestern Bell, etc. In 1982 AT&T merged and thus the baby Bells, Ninex, Bell Atlantic, etc. AT&T retained Bell Laboratories in it. By 1996 we then spun off Lucent which was our manufacturing company and hardware company.</p> <p>That took Bell Laboratories with it, but AT&T retained some of the people and created an AT&T lab. So when I say Bell Laboratories I am talking pre-1996. If I say AT&T Labs I'm talking AT&T post-1996.</p> <p>In either of those laboratory environments, what you would normally do is try to, particularly in Bell Laboratories, they try to have small organizational teams that would look at and design certain technology, and most of that entrepreneurship around technology really stems from</p>

	the technology piece of AT&T.
Rochelle	That is very helpful. I wasn't sure. Some of the companies do it differently, but that makes sense.
AT&T	Some people would say that's the way AT&T did it because they were a technology driven company. Other companies do it differently when they try to work from the marketing end and figure out what the market needs, then go try to spawn that technology. But when you do have a company that works on basic research, which was what Bell Laboratories did, and someone stumbles across something that says hey this could have an application, then you try to use that type technology to drive an application. That is one way it was done inside of AT&T for entrepreneurial type ventures.
Q6	My next set of questions is about reserved human resources, still related to entrepreneurship, but some people call it slack. Does your organization have a reserve of human resources that are available to pursue new opportunities on short notice should they arise.
R6	I think the simplest answer to that is no. I am speaking of AT&T as it exists today, particularly in the state of the telecom industry as it exists today. You may have a small funding, and I will say it is probably tens of millions of dollars, for basic research but there is not a lot of slack of a lot of people that just say, hey, if we have a great idea, let's put these 20 people on it. So, the answer is, effectively, no.
Rochelle	So when it is, for instance you have these entrepreneurial ideas that sound great and the company wants to do them, where do those people come from?
AT&T	Well, there what you might have been able to do is say we're going to fund something inside of AT&T, and not fund something else, but there was not a cash of people which would be readily available to put on a project. Now, what can always happen in any large corporation is you could have a skunk works develop. That is where somebody says, well I'm going to keep, under some other project, just kind of fund this thing and keep it warm as part of another project. So that could always happen, and they are small enough that they are hard to detect.
Rochelle	So is there an area of AT&T where that is more likely, for instance in the labs, or in research and development?
AT&T	Yes, it is probably more likely in a place like the labs, or maybe even in

	<p>software development. If somebody stumbles onto a new technique and they say we're just kind of going to work on this on the side because it may bear some fruit. It's usually kind of done on the side or in spare time type of thing. It is not the most effective way of doing things and, by the way, AT&T pretty much, as it exists today, and I am not going to say the same for the previous AT&T with Bell Laboratories, is not a company at this point. Most of our intellectual property that we develop is probably around methods patents, and things like that as opposed to material patents or new electronic devices. So there are companies, and I would not kind of classify AT&T as one of them today, whose raison d'être to be is to develop new intellectual property. We do develop intellectual property, but we do it purposefully aimed at improving our business. Every once in a while, you might develop some intellectual property that is nice stuff, but really not in the mainstream of our business. In that case, you could let the labs license the intellectual property to someone who is interested, and we do have an intellectual property group that does try to license that technology to other people.</p>
Rochelle	<p>Well, wonderful. That was my last question actually, as far as the phone interview. Now I do have a few questions that are numerical assessment, and I was going to e-mail them to you. You can just answer them and they are on a scale of 1 to 5, if this applies to your company. I e-mailed all my questions to your assistant Shirley Wagner, and I do not know if you got these with that.</p>
AT&T	<p>Yes. I am also looking at questions like #7: describe nature of the resource, and question 8 which was passed.</p>
Rochelle	<p>In the transcribed report numbers 7&8 were applied to other questions. I did not ask those because if you say you don't have reserve of human resources, there is no need to go to those. If you think that you do, I would love to ask you those questions as well if they apply?</p>
AT&T	<p>I would say in general the AT&T that exists today, does not have a group of people that is spare resources to put on a project that, just in case one comes up, we have people to throw against it. Most of the people are purposely aimed at particular business projects. We do have what I would call people working on basic research, it's relatively limited in funding, but their purpose is to create new ideas or technology, so it's a funded research effort.</p>
AT&T	<p>I hope your thesis goes well. I would like to see it, and if we are quoted in here at all, or if you want to come back and ask another question, more probing question or something, and you need to kind of clarify, feel free to do that.</p>

Rochelle	Thank you, and if I need that it will probably be in the next month as I began to analyze all of the data I have collected. So if you need to hear from me it will be in the next month; otherwise, in January you will have a copy of the finished product that hopefully you and my thesis advisor will like. Thank you very much and have a good afternoon.
AT&T	You too. Bye.

Appendix C: Canon Interview Transcript

Interviewer: Captain Jason Whittle

Date: 24 January 2003

Jason	Good morning. This is Captain Jason Whittle.
Canon	Hi! How are you. Give me a little background again.
Jason	A colleague and I are studying innovation in entrepreneurial organizations. We are at the Air Force Institute of Technology at Wright-Patterson Air Force Base in Dayton, Ohio.
Canon	O.K.
Jason	What we are hoping to do is –you know the military is in its time of transformation, trying to think outside-the-box stuff that organizations like Canon have been doing for years. We are just trying to look and see what you guys are doing and see if it can apply to the military in any way. So we will see where it takes us.
Q1	The first question is what caused the company to pursue entrepreneurial ventures and new innovations?
R1	<p>Canon started over 60 years ago in Japan as a camera company, and it just decided in the course of doing business at that time that a lot of its technology had other applications, so gradually expanded that basic imaging quality to other product lines. As we have gotten over the years, as more technology has gotten into digital, we realize that same kind of technology, coupled with or dove-tailed with, optical technology, because we are known for optics-like camera lenses-that mutual technology has brought us unto many more areas of business such as the medical field, providing digital x-rays, and also taking pictures of the retina digitally to test for the formation of diabetes. It has taken us to broadcast lenses, since we are good in optics. A lot of the TV lenses, lot of the TV studios, the major networks--there is only two companies that make those TV lenses, and we are one of the primary players.</p> <p>It has then taken us also into the consumer side, well of course with our cameras, but now digitally with cameras and with camcorders, and those camcorders are not only for the consumer, but we make a professional model that a lot of the Hollywood producers are using. Schools use them, and I believe the military may even use them. I know for a fact that when we had the tragedies at the World Trade Center, FEMA came</p>

	<p>in to record everything, not only for a historical record, but to have a training record.</p> <p>They used our professional model digital camcorders because of not only what the digital technology provided, but also what the lens could provide. So as you can see, it brings us into a lot of different areas of business, and the company is very much technology driven to bring us into new areas. The last 10 years in the US we have been in the top 10, and in the last few years, the top 3 of filings with the US patent office.</p>
Q2:	Describe the key challenge that was faced regarding this venture, or ventures in general, or innovation?
R2:	<p>I think our challenge is unique compared to-lets say if you are talking to a US based company, we are US based, but we are a subsidiary of the Japanese Canon, Inc. Currently over 90% of the research and development, and manufacturing are done in Japan.</p> <p>We did a couple of years ago create an R&D facility in California, and that is going to take a while to rev up and really contribute.</p> <p>The key challenge is the decisions--on what to pursue globally, what technologies to pursue, what markets to pursue—are being made in Japan, and up until very recently, it is whatever Japan told us, is what we had to do. Only recently have they started accepting the feedback—the marketing strategy feedback, what will work here, what will not work here, and it has been a slow process. Now they need to adapt their research, they need to adapt products that might be excellent for the Asian market, may not be appropriate here, or without subsidiary in Europe. So the key challenge to this is that there be a two-way input. We understand what they are working on, but they have to accept back the information that some things need to be tweaked, some things may not fly in a certain market, or certain company in that market, and they have become a little more adaptable to that.</p> <p>Just to put in perspective for you Canon USA, which is where I am here in New York, which is the headquarters for the Americas, takes in North, Central, and South America. Then Westward we have Canon Europe that takes care of all of Europe, the Middle East and Africa. Then you have headquarters Canon, Inc. that takes care of the Asian countries, and I believe they might also take care of, like the Oceania – you know, Australia, Indonesia, in that area.</p>
Q3:	Describe the barriers that had to be overcome to accomplish the challenge.

R3	<p>Going back, the barriers are the cultural differences, and I'm just going to talk about between this company and our headquarters. Europe will have the same problems. It's the cultural differences, the language barrier, also the needs, that Canon for so many years was driven and just putting out the product. Now the challenge that has been met and is being overcome is that they are listening more to what their subsidiaries need. I know for a fact that some of our top executives in our various product divisions go to Japan two or three times each year to have meetings to have feedback, to see what they are doing on the research, and they are to provide input from the Americas so products can be adapted for this market. This did not happen six to ten years ago.</p>
Q4:	<p>Would you say the organization, as it existed at the time the venture kicked off was well designed for the venture, or were changes to the organization design required?</p>
R4:	<p>Canon USA has always been in a state of flux. I have never been in a place that changes so rapidly, and the change is two-fold. It changes to adapt to the market, as each product market we're in is by changes, so in order to compete successfully we have to adapt. Also, we adapt so that we can make the input, and make the cross-communications with Japan work better. So Canon USA is, from a structural standpoint, within the division's product. Product group is always in a state of flux to adapt what comes in from Japan, as well as to adapt to the local market.</p>
Q5:	<p>What were the expected benefits that compelled your company to strive to be more entrepreneurial?</p>
R5:	<p>The bottom line for Canon is two things, of course sells, and that being important to any company, but it is usually not something that is always stressed or important to a Japanese company. Usually in Japan it is lifetime employment and its loyalty. We have a CEO in Japan now who spent 25 years in the US. He was one of the first employees at the New York office before it was a subsidiary. It was just an office, and he eventually became president and started up the subsidiary Canon USA. He adapts from both the east and the west. From the west he adapts-bottom line-be profitable; from the east he adapts the loyalty, lifetime employment in Japan. He has a nice blend of both.</p> <p>Between the bottom line, the employee loyalty, and also the customer satisfaction, we like to hear about a camera that we made 25 years ago. Some people still write in and say "I bought this 25 years ago and I think I got my money's worth; it is still working beautifully". That puts a smile on the faces of people who have been here that long to hear that about the workmanship and the quality. Of course we would like them to buy a new product because that is how you make your money. But to</p>

	hear someone who was that satisfied and said I have never needed to buy another camera that touches you also, to say we marketed it correctly, we manufactured it correctly, and if the person ever needed some attention on it, we serviced it correctly. That's so important too.
Q6:	Does your organization have a reserve of human resources that are available to pursue new opportunities on short notice, should they arise?
R6:	Not here in the US. They will have to be pulled from other existing projects. I cannot answer for Japan. I just don't have the knowledge of what they do. Here, whenever we need to, we pull people who are on other projects and get them to handle the situation as the need arises. I think at least here in the US with the way the economy is, a lot of companies are trying to be "lean and mean". Sometimes you can be leaner than you should be, but that is the nature of the economy right now.
Q7:	Describe the nature of the reserve resources.
R7:	Again, it is the same. We have a lot of people in senior positions who are very good at what they do--whether they have grown internally at Canon, or have come from other companies, or even competitors—and they bring all that knowledge to bear. In a way we are lucky at this point. Canon USA is not a manufacturing operation. All the products come from Japan, though we do have a small manufacturing capability in Virginia for certain parts of products. We are really marketing and sells driven, so we really have to concentrate on the problems in marketing, sells, and take the information that comes back to us. That's when we get it back to Japan to see where things need to be adapted, or if a new generation of a product needs to be created, what is good for the America's market when a situation like that arises. Right now it is just a sells and marketing situation. We don't really have manufacturing. That would take time away from the others.
Q9:	Is Canon centralized or decentralized—the structure? For instance, if people were diverted, these human resources were diverted from one project to another project, a new opportunity, could they be pulled from one product group to another? When they come together for the new product group, or all the product groups, are they all in the same office together?
R9:	Canon is, from what I have found, very silo-oriented, meaning everyone is in their round cylinder, and sometimes, not that there is a lack of cooperation, there is when there is needs to be, but there is sometimes no integration between one group and another, and these groups could be within the same product group. We are organized with divisions

	<p>within a product group. Sometimes the divisions in the group may not even be communicating with each other because they are so focused on the product launch that they have, or the sells situation that they have. So they don't necessarily interact with the others unless there seems to be a need. I guess we would classify the structure as very centralized. There is no divergence. It is not easy to pull someone out to do something else. It takes a lot of approvals and a lot of management thought on that.</p>
Q11:	<p>Can you provide some examples of the types of goals these resources are aimed at achieving?</p>
R11:	<p>It has come from headquarters that we have several goals over the next five years. These include being #1 in the camera market in the world, where we are currently, I think, #3. Also to be #1 in semiconductors in the next five years where we are currently, depending where you are in the US, I think we are #3, in Europe we are #2. So we have very specific goals, and a lot of that is being driven from our headquarters in Japan where they are focusing on these goals and providing us with the products through R&D, that will help not just Canon USA, but Canon worldwide get to achieve its goals.</p>
Jason	<p>Does Canon have any creative capacity, or innovative culture where employees are allowed a specific amount of time during the day, or time during the year to pursue thoughts of their own, or are they always directed?</p>
Canon:	<p>I wish it were the case that we were allowed at that time. I came from a company, and I don't know if it is one that you have interviewed—you may have heard of 3M—but I worked there for ten years.</p> <p>When I left, and I think the philosophy is still there that certain employees, especially in the laboratory, are allowed about 15% of their time to be dedicated to anything they have an interest in that they could pursue that might lend itself to a technology or a product. On the marketing side or the sells side, you could do that to a smaller degree, maybe not 15% of the time, but to pursue things out-of-the-box.</p> <p>The culture here is not that way, and it has been something that I have had a problem with, though I have silently pursued things that some pay off and some do not pay off. It is not viewed that way, and that really comes down from two things. It is the Japanese cultural influence that does not permit that. Then it is the kind of markets we are in. I would not say we are in considerably creative markets, we are in nut-and-bolts markets based on technology, cameras, copiers, printers; these are all highly competitive markets, not necessarily a lot of companies. Maybe</p>

	<p>in some instances some markets might have ten competitors, some might have 15, and some might only have 4, but they are highly competitive within those companies, and you are making nuts-and-bolts products. Why you are better than the other one is really three-fold--better technology, better pricing, and better service after you sell the product. So it is really driven; the R&D people do the technology, the product is created; market, and sell. You don't deviate from that, and again that could be because of the culture. That could also be because of the industries we are in. We are not in industries where you need a lot of, in a sense, creativity. I cannot think of a product off hand, but in you investigation, you would probably say well how creative that is, versus a product like a computer that just sits and functions. We are more in the functioning role rather than the creative role.</p>
<p>Q16</p>	<p>That's a good answer. I will be interviewing 3M later. Are additional resources ever hired or obtained, or were efficiencies ever gained from existing resources to provide the reserve or the creative capacity, or does that go back to your answer to the last question?</p>
<p>R16</p>	<p>We do at times, throughout the company, hire external resources. It could be only because there might be a ceiling on how many people you can hire because of the current economy, so if a project needs to be done, whatever it is, you might need to go externally. Sometimes the expertise just does not exist internally and you need outside support.</p> <p>One example is we have for our copier and printer group, and in that group there is one division responsible for sells training. They train all Canon employees in sells who handle those product lines. We also have independent dealers who are not Canon employees, who we have arrangements with. They need to be trained on the product too because they sell it. We have tried to get away from the traditional classroom type of learning, because you have to take people from all around the country, bring them to a spot, wherever that might be, spend a week in a classroom instead of them being out there selling. They then decided to develop on-line course ware, where 85 to 90% of the work can be developed at the sells person's pace, just like as if you were a student doing correspondence class work. They could do it at their own pace, on line, and then they could supplement that once a year or twice a year with some class work, if they wanted interaction with others, if they wanted to gain more. That resource concept was developed internally. We did not have the capability, the manpower to turn on the switch. We needed this all developed. We went to an outside resource for a year or 18 months to help us develop this, and it became more developed. Now we are managing it in-house.</p>
<p>Q17</p>	<p>Looking at the steak holders of Canon, do they ever balk at perceived</p>

	inefficiency, or something that is in place that is obviously not leaner and meaner, but has a desired impact?
R17:	We get questioned from several areas. One would be our own management who needs to have a mandate, let's say at this juncture with our economy, to make things as lean as possible without affecting the work, but we also get questioned considerably by the financial community. One of our big competitors in printers and copiers is Xerox, if you've heard, over the last year or 18 months Xerox has been in serious trouble. We want to make sure we do not end up with the same situations that Xerox did. We are constantly reminded of that. Also, the financial community, while they'll question our practices versus other companies in the same industry, Canon—even during these economic time which have been tough here, but have also been extremely tough in Japan's economy, Canon every year has turned a profit, and that is because of management style that has been cultivated over the last 10 to 20 years. So we have turned a profit, we continue in this tough time to turn our positive numbers; therefore, we are not peppered as much as a company in a tough situation like Xerox that has to justify everything it is doing. We don't have to justify everything we do to the outside world because we are turning a profit.
Q19	How or when does the firm determine the optimum amount of the creative capacity or R&D?
R19	That is something that is controlled almost like 98% in Japan, and I wouldn't even be able to go there.
Q21	Has there been within the organization, when there are the additional hires, what has been the primary outcome of this availability of the additional resources? Has it been widely successful, kind of because of the nuts-and- bolts operations there, whether they are permanent or temporary hires?
R21:	I can only speak for what I see here in New York as we are at the headquarters. We are in a funny position. We are located just on the beginning of Long Island, right outside of New York City. Because of the dense population, and it can take you an hour to get to work by car because of the traffic patterns, we really cannot pull as diverse a group of highly trained people as if we were located, lets say, in Manhattan. If you were in Manhattan, you have the railroads and other mass transit. You can pull people from Jersey, from five boroughs of the city, but also north of the city to get into southern Connecticut, as well as Long Island people who filter into Manhattan. I would say that over 85% of our workforce is either from Queens County, which is one of the boroughs of New York City which we are right on the border of, or

	<p>Nassau County Long Island which is where we are actually located. I would say about 85% of the workforce comes from there, so now you are drawing from a smaller pool of talented people.</p> <p>Sometimes I feel, and it's my personal feeling, we don't receive the top of the talent pool. We are not tapping the best because some people do not want to commute two hours, and get stuck in traffic, and spend two hours coming in and two hours going home at night. We have some people who do that, mostly in higher management. The average person would not do that.</p> <p>Sometimes if you have a person like myself, I live 20 minutes from here, and I worked in Manhattan for over 20 years. I just decided I had enough of the commute, and I wanted to back off that for a while. It is your life style. I have a son who wanted to make sure I make his little league games, make other school events, now I want to be a little closer, so I decided to make a life style change. Most people will not. Most people want the excitement in Manhattan, the high paying jobs in Manhattan, and, of course the best talent goes there. So, it's a trade off for the company.</p>
Jason	That is it for the phone interview. If it is O.K., I would like to be able to e-mail you a couple of pages, and it might take you 10 minutes to do it?
Canon:	Fine, do you have my e-mail address?
Jason	Yes. Any parting thoughts?
Canon:	Nothing I can readily think of. I think in my detailed responses to you everything should be pretty clear. It is just if you are talking to us versus American companies, we have a distinct difference because we are driven by our Japanese parent who has cultural differences. Again, we don't manufacture here, at least not yet, so we have unique circumstances, but we are a company that is seen, both in Japan and here, as one that kind of is bucking the trend, especially in the current economic situation. We are making profits. It is not necessarily maybe the goal we set maybe a year ago to be at adjusting for the economic conditions around the world, we are still in the black. We are not losing money, and we have not had the need, like other companies, for layoffs. We have a leaner situation, not because of layoffs, but because if someone leaves, they may decide at this point, we don't know where the economy is going so lets not replace that person. So it's more to attrition, at least at this point. We have not had any significant layoffs of any kind.
Jason	Thank you so much for your time.

Canon	When do you need a response on that e-mail?
Jason	I've got a couple of weeks, so if you could find 10 minutes?
Canon	I'll keep my eye out for it and I'll probably get it back to you the same day or the next day. Goodbye.

Appendix D: Dow Interview Transcript

Interviewer: Captain Jason Whittle

Date: 22 November 2002

Q1:	<p>I am working with one other person and we are looking at innovative and entrepreneurial organizations. We are just going to ask them some questions about it, then we will try to map that to the Department of Defense. This is the first time anything like this has been undertaken, so we are just kind of laying the foundation for it.</p> <p>Question 1 is what caused the company to pursue entrepreneurial ventures or new innovations?</p>
R1	<p>People do this because they need to grow and they need to make money.</p>
Jason	<p>Has Dow always been doing this, or was it a change?</p>
Dow:	<p>Certainly for the last 25 years.</p>
Jason:	<p>Did something happen at that point, or was it just a decision?</p>
Dow:	<p>It became obvious that our existing businesses were not going to be adequate to take care of our growth fantasy.</p>
Q2:	<p>Describe the key challenge that was faced regarding this venture or innovation?</p>
R2:	<p>I don't know if there is one---you know this is a very program and there are lots of things going on. There isn't any one project, and they are all sort of their own animal, so there isn't a generic answer to that question.</p>
Q3:	<p>This question is kind of similar, but can you describe the barriers that had to be overcome to accomplish the challenge?</p>
R3:	<p>You have to generate more revenue.</p>
Q4:	<p>Would you say the organization as it existed at the time the venture kicked off was well designed, or were changes to the organization design required?</p>
R4:	<p>All of these are works in progress, so they are in a continuous state of flux. The probability that you are going to correctly anticipate all of this at the beginning is zero.</p>

Q5:	What were the expected benefits that compel your company to strive to be more entrepreneurial? You touched on that in the first question. Is there anything else you want to add to that?
R5	No.
Q6	This is going to be a lot shorter than 30 minutes. Does your organization have the reserve of human resources that are available to pursue new opportunities on short notice should they arise?
R6:	No.
Jason:	How does your organization adjust to opportunities that do rise? Do you reprioritize?
Dow:	Yes.
Jason	Does that happen pretty continuously?
Dow:	No, on an as-needed basis.
Q8	Are these people in all types of jobs, or are they specifically research and development, anything like that?
R8:	If you have this activity centered in research and development, you are guaranteed to fail. So the answer to your question is they come from all over.
Jason:	You want to expound on that, I've never heard that?
Dow:	Well, R&D organizations are preoccupied with technology. The development of new businesses may or may not have a technology component. So if you are limiting yourself to technology then you are keying yourself up for disaster.
Q9	That's an answer I haven't heard yet, so I am kind of excited about it. Is the organization centralized or decentralized in the supporting structure? For instance, you kind of inferred earlier that Dow has multiple business units, and I guess the head of each business reports to someone else. Right?
R9:	Yes, the president.
Q9	Does each business unit have a fair amount of latitude to make the decisions? In some organizations they spawn business units, and these business units, for the most part, are a separate entity. Is it that way

	with Dow, or is it more centralized than that?
Q9	No it is not that way. Generally the existing businesses are not a very good place to try to do this, because they will spend all their resources on the existing business. So, if you localize new business growth, other than line extension type stuff in the business, you are guaranteeing nothing is going to happen.
Q11	Can you provide examples of the types of goals that the resources are aimed at achieving, such as process, product improvements, specific markets, anything like that?
R11	We spend about \$300,000,000 a year in trying to develop new businesses. In other words, non-line extension type work.
Q14	Do the people within the firm have an allotted amount of time, or are there specific people who are sat aside to be innovative?
R14	Innovation is a full-time job. If you are trying to innovate with part-timers, you don't understand the issue. There are specific people who are doing this full time.
Jason	Are people who are in support organizations given any kind of leeway to improve the processes that they do from day to day?
Dow:	Yes, but that has nothing to do with innovation. That is in operational, transactional type stuff. Leeway to improve the processes is there all the time, but that has nothing to do with new business development.
Q16	Do you ever hire or contract for additional people? Is it a frequent thing, and is it on an as-needed basis?
R16:	Sure. If you can do this kind of activity outside the company it is always an advantage, at least in the early stages. This is on an as-needed basis.
Q17	Do the stakeholders of Dow ever balk at any of these investments, or do they just accept it as part of the way you do business---these new business ventures?
R17:	We are a publicly owned company with about 100, maybe 70 million shareholders, and for whatever reasons, they vote on whether or not they want to hold our stock every day.
Jason	So there are no instances of having to convince them other than your bottom line, in a further stakeholder, large shareholders, anything like that?

Dow	The biggest shareholder in the company owns maybe 2%. This is a non-issue for big public companies.
Jason	Does your firm ever participate in business process re-engineering, or things like that?
Dow:	Yes, but again, this has nothing to do with new business development. People re-engineer processes because their existing business is in trouble. This is hardly where you go for innovation.
Jason	In the Department of Defense the way we do business, is we need to find deficiencies by doing things in different ways.
Dow	So do we, but in the context of developing new business, that's a separate question. All organizations try to improve their operational efficiency, but you normally do that by slashing cost.
Jason	I would say that concludes it. Do you have any closing thoughts on anything?
Dow	<p>Basically, developing new businesses---which is what I thought the target was---fundamentally the way that process works, basic research is done by taxpayers through things like the NSF, The Department of Defense, NIH, who basically give money to national labs and universities.</p> <p>The next step in that process is to venture capital industry. It basically takes the output of the basic R&D and does reductions to practicing prototypes. Then other people pick that up, and they either buy those companies, or those companies go public and become companies themselves. That is kind of the process.</p>
Jason	One last question, if you don't mind. Within your support organizations, do you strive for 100% efficiency within your processes?
Dow	Yes, I suppose. Again, innovation and efficiency tend not to go into the same sentence.
Jason	Thank you very much. I appreciate this, and good luck with everything next week.
Dow	O.K. Thanks. Bye.

Appendix E: Duke/Fluor Daniel Interview Transcript

Interviewer: Lieutenant Rochelle Smith

Date: 8 November 2002

Rochelle	Hello, this Lieutenant Rochelle Smith. How are you this morning?
Duke	I'm good, how are you?
Rochelle	Doing pretty well. Basically today--I think I sent you a copy of the questions, correct?
Duke	I don't see anything on my e-mail.
Rochelle	<p>No problem. Some people have asked specifically for the questions beforehand. What I have is a total of 18 questions that are guided-answered, and so some of them you might answer three questions at one time, so I won't ask all of them, and if we are running out time, again, I won't ask all of them. If you want a copy I can send it to you. I'm just trying to get you to talk about what your company is doing, and for some people it is more difficult than others.</p> <p>The first question is what is the title or job position of your supervisor?</p>
Duke	President and CEO.
Q1	What caused Duke/Fluor/Daniel to pursue entrepreneur ventures or new innovation?
R1	<p>The short answer is to make money. In the business we are in, which is engineering procurement, and construction, then operation and maintenance, we're a partnership of two parent companies, Duke Energy, and Fluor Corporation. They are both very large companies in their own right, both Fortune-probably 100, and in the list of most admired companies. So we focus strictly on the power business.</p> <p>In DFD, to answer that question, we do entrepreneurial things because, one, we have the capability to do them, where our competition may not, so it provides us a niche in the market. Secondly, it provides us an opportunity to make money, which is what we are in business for. It sounds cold and hard, but that is what we are here for, to return value to out shareholders. Thirdly is, just the definition of entrepreneurial means taking credible risks, and we have the ability to manage risks.</p>
Q2	After your company decided to do that, what were some of the

	challenges faced by Fluor/Daniel or even each of the individual companies, before you became a partnership?
R2	<p>I think the first one has to always be around the area of selectivity. You can be entrepreneurial, and if you're not selective, you are going to get into some deals that will cost you money, and waste certain efforts of the workforce that you are trying to make very efficient. You can't avoid getting into some deals that maybe are less than economically attractive, or less than the risk profile you are looking for, but if you don't have a good screening process, and you don't adhere to a regimen of selectivity, you're going to find yourself in trouble as an entrepreneur.</p> <p>The second part of that is maintaining credibility. If you want to be looked at by, especially in that business, the financial community, investment and commercial, and by other clients or customers that you are serving, you'd best come with a lot of credibility. Don't do deals that don't appear to have good thinking or all of the homework that you are supposed to do in a deal. Don't take those on. If you don't bring credibility, you will never finish the project you are taking on. A lot of people try to be entrepreneurial, and they come in with less than well thought out plans as it regards to the whole life span of the process. If you do that, you may well entrust others to go along with you, and in two years from now, companies have done this and found themselves in chapter eleven and they can't perform, and they take everybody else down with them.</p>
Rochelle	In your company, do you actually have an individual, or group of individuals, that if I have an entrepreneurial plan that I thought would be great for Duke/Fluor/Daniel, would I present it to them, or is it depending on where I had that plan that it would be brought to an individual or to a group?
Duke	Generally, anything like that, whether it is a new opportunity, or new perspective thought process like that and needs to be evaluated, to be honest, that comes through me. I'm Senior Vice President of Sales and Marketing, and as such, it is my job and the responsibility of the people that work for me to screen and manage these opportunities, if we believe it passes the first "sanity", so to speak. Then we would leverage others in the company such as our financial group, and in the parent companies the strategic initiators groups, and those that look at investments or acquisitions.
Rochelle	So there are different levels that you need to go through the plan with?

Duke	There are different levels, but it starts with the sales and marketing function to screen and put some meat around the opportunity to prepare it for the others who need to help in those decisions.
Q3	What were some of the barriers that most of the parent companies have experienced as you've tried to accomplish this change?
R3	<p>I think (and this is one of those maybe related questions) one of the first barriers is that people tend to put entrepreneurial thought in the “too hard” basket. You know it’s more work to think through it and go through all the regimen that is required to qualify it as something you want to do, and with the busyness of everyone’s schedule, just the fact that it is a new thought or an outside-the-box thinking type of approach, it does not get the attention it may deserve. So, just the thought process of not taking the time to quantify and qualify it—that’s one barrier—because of current schedules and workloads.</p> <p>Another is lack of funding in a priority fashion. Today’s corporations have to do several things. They have to protect their credit rating. They have to watch their cash position. They have to balance the amount of debt they are taking on with the cash that they have.</p> <p>Sometimes the barrier is simply “we can’t take on anymore risks at the moment. So it doesn’t get its day in court, if you will.</p> <p>Other barriers just may be not having the right people in the right place at the right time. There is just resource limit. You can’t do everything for everybody.</p> <p>Then I think a final is if you or I, are the one’s initiating an entrepreneurial action, we may think of it as the greatest thing we have ever seen, but it may not fit the strategic plan of the company that it is being served up to. If it doesn’t, if it’s just a little bit too outside the balance in the public sector (people’s credit ratings and balance sheets are valued by Wall Street, and their stock rises and falls accordingly), taking on some things that look like they are out of your core competency, a lot of times will get a negative reaction, no matter how good it may be, so that is obviously a barrier.</p>
Rochelle	Now, when Duke/Flour/Daniel first began becoming entrepreneurial — you could just think of maybe a specific venture that the company took on--what was the mindset of the company at that point—when it moved from not being an entrepreneur to becoming entrepreneurial?
Duke	The mindset was probably that we’d better get some training in place. We don’t want people going off using their own instinct to drive this

	entrepreneurial idea. We want communication to be very focused. We want to make sure everybody understands the task at hand, and more importantly, what is the expected outcome?
Q5	What was an expected outcome at that point? Was it just to make money?
R5	<p>That would certainly be the underpinnings of it, or you wouldn't be getting into it, but the expected outcome was the litigation and management of the risk of the activity to quantify and qualify that, and that doesn't always have to be money. You can quantify and qualify risks in your contractual language, for example. Where you cannot do that, then you have to provide a contingency to make sure that you are going to be able to manage it properly, and bring in all the required associated portions of your company to support it, and make sure it is going to be successful.</p> <p>I think the other thing is you have to have a mindset that this is not a two-month window type of opportunity. You have to give it a fair chance, and you have to make sure you dedicate the resources that are necessary to get it done.</p>
Q6	We have some questions about critical capacity, also known as slack. Does your organization have reserved human resources that are available to pursue new opportunities on short notice?
R6	I'd say the general answer last year would have been absolutely not, because in the power business we were in a peak market. Everybody was fully utilized, and we had more personnel than we have ever had in the history of our company. We are in a down turn market now, and because our business happens to be cyclical, we do tend to have more bench strength, and we have people that can be assigned for these kind of initiatives that are outside the general core competency or adjunct to it. I hate to give you an answer that is not just black and white, but it does depend on a particular cycle of our business that we are in at that moment in time. However, if we think it's a valid enough opportunity, we will create the people to do it. We will borrow them from our parent companies, or we will go hire them if we don't have them. It doesn't become a constraint to say we don't have the people, therefore, we cannot do it.
Q7	Then the nature of reserved resources you have, does it depend, or is there a certain nature that you usually have of these reserve resources?
R7	In our particular business we do things in teams, so you would have project teams for example, or home office engineering design teams, or financial estimating teams. They are all functional responsibility. What we find is when we do have bench strength or reserved resources they

	are across the whole line. We have them because any particular project finished and there is not another one for them to go to, so it would generally be a full-service line from, in our case, design all the way through all the disciplines of the work that we perform that would be available in some form or fashion. We don't have a think-tank group sitting along the sideline that does research, R&D for example--we don't have that.
Q9	Are your reserved people centralized or decentralized? Do they report to one person, or to a wide variety?
R9	Their account responsibility is up through their discipline to one person. They have an immediate supervisor, then that supervisor has an ultimate person that is accountable, such as myself, or the President I report to. We also have a matrix organization where those disciplines work across various lines to support one another. The true accountability is vertical.
Q11	Can you provide examples of types of goals that the company has by maintaining this excess number of people?
R11	Yes. The first one is to maintain core competency. The second one is if and when we have a reserve of these people it is because we want to maintain an ability to address a new strategic initiative, or uptake in the cycle of the work, the industry that we pursue. Uptake is not a very good word, but an increase in the need out there for the services we provide. The third leg of that is just to be able to react to an opportunity that may or may not be core competency, but just by the nature of our business, you can never be 100% utilized. You are always going to have some of that capacity where you can do collateral functions. That's what we find, and I'm forever, when a new opportunity comes in the door, assigning it to someone who, for all intent and purposes, their plate is normally full. We can always seem to stretch to take on one more thing.
Q12	Did you always have extra capacity, or was that something that you intentionally implemented?
R12	Yes, I think it is just the nature of the industries we serve. It creates itself. We do not intentionally ask for the backlog that we have in hand, and the new work prospects that we are pursuing, and say we need "X" people, and "X" people only, then let's go out and hire 50 more. We don't do that. We suitably size ourselves to the projected needs of the work we are pursuing and the backlog we have in hand. Sometimes we

	will miss it, so we normally have a little of bench strength. Unless we get in an all-out peak market like last year's power market, which was just unparalleled. Then we would not find an extra person if we needed them.
Q14	How often are these people that you might have that received a little bit of extra capacity being innovative—one hour a day, or 15% of the time?
R14	That is hard for me to quantify, but it is not anywhere near 50/50 of their time. If you say the one hour a day, that is probably generous, because in our particular industry, there is no R&D department sitting around looking for these kind of opportunities. By their normal research and interrelation with outside entities such as banks and customers and other developers and entrepreneurs, and so and so forth, I would say an hour of their day is probably about right in terms of the interaction they have outside of doing their normal function.
Q20	How often does this change? What measures are you using to determine the effectiveness of the capacity that you have?
R20	We do that on a very routine basis, because if we have too much overhead (I think I just called human resources overhead) if they are not assigned to projects they are overhead, and you have to cover them with dollars, or what drops to the bottom line is less, and you effect co-balance of what you are trying to accomplish, so it is very routine. We have a human resources group and we have our financial or accounting group that looks at the bottom line on a daily basis for accounting purposes, then we report quarterly to the market. That is an ongoing routine function of evaluating our staffing loads.
Rochelle	So you are using number of people to measure that? Each quarter you are measuring it, but what measures are you using?
Duke	<p>The measures are the amount of work in hand versus overhead needed to perform. What is left is the utilization factor. If people are being 90% utilized that means 10% of their time they are flexible enough to do some of these other things. For the most part, we are project specific I most cases. Maybe Microsoft, for example more than likely have a group of people who sit around and do exactly the focus you are talking about. That is their day—that is what they do. The turn rocks and they look for opportunity.</p> <p>We are more opportunistic about that, because we are doing a detailed function most of our day, but we are looking for the opportunity to create new challenges and new ways to stretch our charter, more than adjunct of what we do.</p>

Q21	What has been the primary outcome resulting from the availability of additional resources?
R21	The ability to expand our charter to build more resource capability, because once some of the ideas that come out, and challenges that we take on are adopted, that generally leads you to build on to that function, so by nature you become a larger company and/or you become more thoughtful about how these people can leverage your business. Also, you began to look at capabilities you may have inherently, and you look at the landscape, you say well I'm not participating there, but I have that capability. So you create the opportunity, then go market that so people know you have it, then leverage off of it.
Rochelle	Wonderful! You have been very helpful. We have a few more questions that are just numerical, 1 to 5, and I was going to e-mail those to you. I have your e-mail address. If you can get them back to me by next Friday, that would be wonderful. All of the questions are 1 to 5, and if they don't apply feel free to skip any of them. There are instructions at the top. If you have any questions for me, feel free to call me or e-mail me as well, whatever is easiest. Right now we are still collecting data, and we will be writing starting next month, so if you want to see the final product, or have any questions about how we are using your interview, feel free to contact me.
Duke	I thoroughly trust the government.

Appendix F: GE Capital Interview Transcript

Interviewer: Lieutenant Rochelle Smith

Date: 25 October 2002

Q1:	What caused GE to pursue entrepreneurial ventures or new innovations?
R1:	Because we are a financial company, it's always managing growth with making good risk decisions—you know, for balancing out, trying new ideas without putting the balance sheet, or write-offs or anything at risk. We have to always look at that.
Q3:	For the barriers that the companies had to overcome, is that one of them?
R3	Yes, the risk part is definitely one of them. I think the other is probably pricing—how you price a product. I'm on the financing side, not the new product development side. Our products are really structuring transactions. I would think risks and pricing probably are the two.
Rochelle:	When GE decided to become more entrepreneurial for growth reasons, did they call that something? Most companies call that something, and we refer to it as a venture.
GE:	I don't think GE is a big de novo venturer to start up stuff. I feel if you think of GE for GE, for us entrepreneurial would be creating better products and services—coming up with a new product this year; that kind of entrepreneurship, or possibly buying a company that is synergistic to what we do. I do not think we necessarily just start up new things. Most of our company is 100 years old. We are not creating new software, or something like that. We tend to buy companies that can align with our offerings, and then maybe look at innovation more on a product development side.
Q5	What were some of the expected benefits of being more entrepreneurial—for trying to grow, or trying to buy new companies, what's the end-all benefit that the company is looking for in that?
R5	Bottom line growth. I think from a GE perspective, the company was very much focused on cost, productivity, and things like that traditionally. You know, when Jack came in and restructured the company, he always wanted to be one or two in a product set. So his viewpoint is, you can only take car theft for so long, and then you have to really figure out how you are going to expand you revenue lines. You want to do that through innovation, and innovation can be buying new companies, developing new products, thinking of how to structure deals differently.

	So for us, I think it really is all about how you expand your penetration within a market, and just draw the top line.
Q6:	Does your organization have a reserve of human resources that are available to pursue new opportunities on short notice if a new opportunity arose? Then where would those resources be?
R6:	Yes. They traditionally come out of our program. GE has fairly sophisticated programs, like the audit staff. We have a lot of development programs--we hire externally; so we have an audit staff, we have a financial management program, we have a technical leadership program, a risk management program, an IT leadership development program; there are several of them. Those resources are kind of young, green, energetic people who go through a program, and as they off rotation they are kind of new resources available. But if we ever have something where we are really trying to drive hard, the audit staff is a big organization for us that we'll pull on if we have additional needs.
Q9	Who do these additional resources report to? Is there is one centralized place?
R9	Each one of those programs has program managers, so it is centralized. It is up to HR, except for audit staff. Audit staff is financial, but the FMP program, or some of those other programs are through HR.
Q11	Can you provide examples of the types of goals these resources are aimed at achieving? By maintaining these people, what is the goal for that?
R11	I think the primary goal is creating future leaders for the company. That's the primary goal, with specific skill sets, so by hiring in and training them within certain areas they become the future leaders within those functions, with the exception of Audit Staff, who, if you look at GE, probably more than half of CEOs are former audit staff people.
Q12	Has the firm always had extra capacity? Has GE always tried to maintain this, in the audit staff of elsewhere?
R12	Yes. I've only been here six years, but the audit staff has been around forever—I mean years and years, like over twenty.
Q13	So why did they do that to create that extra capacity?
R13	Originally? I don't know. The audit staff obviously is the audit staff. They look at the financial internal where withal of the company.
Rochelle	Did they get to see the whole company?

GE	Maybe they have some kind of free reign around and we'll throw them up against tough acquisitions, or integrations, or things like that, because of their financial acumen. My sense is that's why they were there, but I think the initial intent was to be sure we're doing all the right things.
Q14	For your creative capacity, when is it that they are being innovative? For instance, one hour a day that you would estimate that they were being innovative, or 15% of their day?
R14	On the product development side, we have a whole couple of centers where that is all the people do—100%, is be innovative. CR&D, which is our global research and development centers, and we have multiple centers where 100% of their job is to think up new ideas. It's a separate team and group that used to be state of the art; we are now enhancing, and making them state of the art facilities. You know, they are kind of think-tank kind of people, and basically it works two ways. They work with individual businesses within GE to come up with new product innovations, software innovations in some cases, maybe risks models or whatever, and there is individual expertise within that center. On the industrial side they will work very closely with the engineering organization and marketing organizations. On the financing side they may work with our risks organization or pricing organization or marketing organization.
Q14	So this is depending on which department it is?
R14	Yes, and depending on what we are developing. Obviously some product development takes years, right? If we are creating a new engine, it takes a long time to create this, but if you are dealing with a new feature on a refrigerator, that might be something different. These guys really do the bigger ideas. That's probably a bad example to use—you know, the refrigerator. These are bigger idea people, thinking of making something different than refrigerators, you know, out-of-the-box kind of thinking, and they are put in an environment where they have the luxury to do that.
Q15	How was standard capacity implemented? Was it incremental, or radical? Was it a long period of time or a short period of time? When you decided to implement these people for instance, did you take them out of one department, your auditing for instance, is that done all at once, or do you take them out one at a time, and place them elsewhere as they are needed?
R15	I think it is more where needed, if we need them.

Q16	Were additional resources hired or obtained, or were efficiencies gained from existing resources?
R16	We never go outside. We always stay internally.
Q17	What about your stakeholders, did they ever question you on the inefficiency of having extra resources at a given point in time? Could you say they are there and they are being fully utilized?
R17	I don't call them extra resources. We don't really have a lot of extra energy. It is kind of a structure that has been put in place that I think we leverage as we need, but their fundamental job is to audit the financial to make sure we are doing our thing. If a new initiative comes out, like when we were making the Honeywell acquisition, I'm sure we had the audit staff helping us on that. I think there is enough of them so that we can get basic day-to-day stuff done, because that we are not going to mess up, but then there is enough within there that we know we are always going to have these different things pop up.
Q19	So then how does GE determine what the optimum amount is? So if everybody is working and something new pops up?
R19	I think they have been pretty consistent on the numbers they have, so they kind of have a rhythm in that I think. I think if there is dire need somewhere, they would pull them no matter what. It's kind of built into the plan that they know some of us will be working on this, and some of us will be working on new things.
Q20	Is there a specific measure that they use to indicate if it's being effective, or if you have people who could be doing more?
R20	The CFO manages most of that on the audit staff side. On the R&D side, I think people look at that all the time; double checking to see if they produced anything, and some have been put against very tight time lines, and then budgeted so they get clear budgets that they need to work within.
Rochelle	Well, that was my last question actually, and you are the most efficient person that answered any of my questions, and I do appreciate it. Did you have any questions for me about our study?
GE	What do you want me to do with this other information?
Rochelle	You could just answer the questions, or we could do it over the phone or you could e-mail it to me.

GE	I'll just e-mail it to you. I have kind of worked on it. What are you doing anyway?
Rochelle	<p>This is a thesis research for my Masters thesis, and I am at that Air Force Institute of Technology in Ohio at Wright-Patterson. Basically what the Air Force and the Department of Defense are trying to do is to become more innovative and more entrepreneurial, but they do not know how to do it. So what they have asked us to do is talk to private sector companies, asking how they became entrepreneurial, what benefits were you looking for and what barriers were encountered. Some of the things will obviously be very different just by the nature.</p> <p>We have tried to get a wide range, and many companies have been very helpful, just talking to us. At this point, however, the Department of Defense is not even sure which organizations they are trying to implement it in. It might just be maybe the Air Force Finance Office would be only one they change, or they are trying to see where they could change it, or when we work with other companies like Boeing or Lockheed and Martin, how we could work with them and be more entrepreneurial with them, since they are entrepreneurial in many ways and we are not. So we are trying to decide, and basically my thesis will be a recommendation for how we should proceed. The next person that follows onto my work will be saying these are some organizations in the Department of Defense that we can look at in hopes of working with.</p> <p>So that's where are right now. We are very much in the infancy, so a lot of the questions we are asking, we're hoping that they are the right questions even. We will see if these are the ones that the Air Force can use.</p>
GE	My reaction to some of this is I do think, the ones that I was looking at was to kind of get a gauge on the company itself. I think there are cultural assets in the company; but just as a thought, like when you do these questions, to take that into account more with the questions. That makes sense too, because I've worked at other companies, and the big thing about GE that I think makes it very different is kind of like the whole structure, and culture of the place. I just don't think you get that everywhere.
Rochelle	That makes sense, especially considering the work we are doing; there is a very strong culture here too. That definitely will play into it and that is the sort of thing that we need to be hearing.
GE	So whoever does the next one should really try to understand the cultural. You ask some of them in here, but even focus more on that, because that is going to be one of the things you might encounter for

	sure.
Rochelle	Thank you very much for your time. Have a good day.

Appendix G: Intel Interview Transcript

Interviewer: Captain Jason Whittle

Date: 22 October 2002

Jason	Good morning! This is Captain Jason Whittle. How are you this morning?
Intel	Hi! I'm pretty good. How are you?
Jason	Good! Do you have about 20 minutes?
Intel	Sure.
Jason	O.K. Great. The questions here are open-ended. Just say whatever comes to mind, even if the questions are not completely clear. First, would I be able to e-mail you a questionnaire that will take about 10-minutes, with scale numbered answers?
Intel:	Sure.
Jason	What is your position within Intel?
Intel:	I am a Strategic Communications Manager, and I have the Technology Press area.
Jason:	Who do you report to?
Intel	I report to the head of the Press Relations Organization. They report into the head of the Corporate Marketing Organization.
Q1:	What caused the company to pursue entrepreneurial ventures or new innovations?
R1:	That was actually in our life, blood. When the company was founded by Bob [redacted] and Gordon Moore, and Andy Grove joined them almost immediately, they all came from Fairchild. Their whole thought was to create a new type of large-scale integrated circuit they had been working on, and developed from the basic transistors and integrated circuits at Fairchild. They came over to Intel to create a semiconductor memory chip, and then things evolved from there. So we have had innovation as our starting point from the beginning of the company, and it is one of the things that has remained with the company every since then. We view ourselves as a company that has innovation as one of its added values.

Q2	Describe the key challenge that was faced regarding this venture or innovation, or ventures and innovations in general.
R2	<p>I think that Intel, like any start-up, (we started up in 1968) you have a set amount of money that you've got, and you've got, hopefully some tricky problems that you are going to try to solve to allow you to bring a product to the market place. In fact, Gordon Moore describes Intel's initial effort as pursuing three problems, and kind of calls it the Goldilocks Theory. They had one problem, which was a bipolar memory device called the bipolar ram, and it was fairly easy to solve. They solved it, got the product out, and it was the first product that Intel made, but it was easy enough that others could also solve that; so consequently they had competitors much larger than them in the marketplace with the same product very quickly.</p> <p>They had another product idea they were pursuing which was multi-chip modules all in the same package. This was a problem that the industry only solved a few years ago, and again we started in 1968. So that was a problem that was too hard, and if that would have been their only avenue of pursuit, we would have run out of money way before they would have ever solved the problem.</p> <p>The third one was just right. It turned out to be a MOS, silicon metal oxide semiconductor, and that was a problem that was technically difficult enough that, by focusing on it, having some very smart people do some clever work, you could solve the problem. It was easy enough to solve, but difficult enough that competitors could not do it casually. They would have had to focus an effort on it, and it took them several years to do so. Fortunately, the company not only solved the problem, but was able to get its products into the market and establish a customer and revenue base before it faced significant competition. So that was kind of how Intel approached the early days.</p>
Q3:	I think you touched on this some, but can you describe the barriers that had to be overcome to accomplish this challenge or these challenges.
R3:	<p>I think that discovery is a fickle thing, so you are going out to solve problems that exists, but there is no known solution yet. So, you are kind of betting on your own skill, your own intuitive innovation, and placing a bet against that versus time and money. Sometimes you don't get there; the inspiration does not happen, the experiment doesn't work, and things don't work out.</p> <p>In Intel's case, they were able to solve some technical problems, create a product that people wanted to buy, successfully get out and communicate that they had this capability for sell, and set up a</p>

	<p>successful sales activity as well. If you make a product in the commercial world but you can't get the word out or can't get it sold, can't get made or distributed, then you still aren't successful as a commercial enterprise. So they had to go through all of that early learning in the very early years of this industry when a lot of things that we would take for granted today didn't exist.</p> <p>The equipment to build the things you are trying to build, when the things you are trying to build are not yet discovered, doesn't exist. So, you have to either make your own, or you have to work with others that create that type of equipment, and convince them to make the equipment that you need to buy. All of these are difficulties.</p> <p>I am often up in the Sierra Nevada here in California, and I look at places that we cross over the mountain range on these large freeways, and try to imagine what it was like for pioneers with wagons trying to get across these mountains with no roads, and physically taking the wagon apart, and piece by piece carrying it over the mountain, and reassembling it on the other side. I think of how many trips back and forth you'd have to make, and how difficult is just to walk without anything impeding your effort, let alone having to transport your worldly goods.</p> <p>So, pioneers, whether it be in technology, in business, or in the classic sense of expansion in our history, they face a tough road. They have to solve many, many problems, some of which are minutia, but critical if you are going to reach the goal.</p>
Q4:	<p>Would you say the organization as it existed at the time of the venture kick-off, or again generally, kick-offs and innovations, that the organization was well designed, or were changes needed?</p>
R4:	<p>I think it was pretty well designed. Our people had been through a start-up of Bob [redacted] and Gordon Moore, then two of eight founders that started Fairchild semiconductor. So they had kind of been through the process at least once before, and had some ideas on how they wanted to run Intel when they created it. So it was a different structure that what was typical of the big companies of the day, and obviously as a start-up you are not a big company. This is a company that was predominantly formed by scientists and engineers.</p> <p>I think a lot of the core structure and organization revolved around a similar structure that you would find in a research lab setting, where you do have a person in charge, but really it is a collaborative effort amongst peers. Everybody on the team has expertise and knowledge that they are expected to bring to the problem, and everybody operates predominantly</p>

	<p>more at an equal level. Then, there is someone that ultimately has to make the final decision.</p> <p>So I think that was the basic structure then, and Intel really had not changed that much over the years, even though we have grown to be a very, very large company.</p>
Q5:	What were the expected benefits that compelled Intel to strive to be more entrepreneurial?
R5:	<p>I don't know that the word "more" fits in there, but the benefits of entrepreneurship were that we were a brand new organization and company. So the biggest motivation is survival. No motivation, in our particular business that we were pursuing, meant no success, and consequently, no company, and meant you would be back on the street looking for a different job. So survival is the first thing.</p> <p>The second thing is do you have a great idea that you think is going to have an impact on the world? Intel's first idea was semiconductor memory, much more cost effective, much more reliable, much lower cost ultimately, than what was the standard of the day, which was a magnetic core memory. Along that road as we went through that path of both discovery and development of that product line, we had smart people who came up with additional ideas such as the microprocessor, such as the erasable read-only, programmable read-only memory that used the same fundamental skill-set that we had developed to create semiconductor memory, but provided completely different attributes--- the microprocessor being the brain of the computer, re-programmable with software. Next was to take these additional discoveries, recognizing the ones that should have great promise, then being able to bring those capabilities to the market place, and be successful in marketing those that allow you to grow from a small, successful start-up to a continually growing, successful large business.</p>
Q6:	Does your organization have a reserve of human resources that are available to pursue new opportunities on short notice, should they arise?
R6:	Not in the way that is described. I think that, like anything, you have the ability to readjust priorities. If you look at Peter Drucker's definition of entrepreneurship, it is taking resources from an area of lower return and moving them into an area of higher return. So, in that sense, as an organization you always have the ability to readjust your priorities and move resources from an area you perceive of lower return on your investment, to an area of higher return on your investment. You don't have a group of people sitting around with nothing to do, waiting for somebody to come up with a grand idea, to jump to it. The reality is that

	<p>most of the ideas come off of the work that you are already doing, and you will want to tap into the thinking and the skills of people that are involved. So people who are sitting, their skill and knowledge is sitting, and that is usually not going to do much for you.</p> <p>If they are involved in developing and refining, and improving a given aspect of your product line of whatever it is that you do, and they come up with a clever idea, an opportunity that off-shoots from that, you will want to take part of that team, and have them pursue that new element. That means that you have a core there that knows what direction you are heading in. You can always hire and supplement and customize some of your skill-set, but you do not want an idle pool sitting around waiting for somebody to walk through the door with a great idea.</p>
Q9	<p>In general, these R&D groups, I guess is a good way to describe it, is it centralized or decentralized, or has it even changed from the start-up when you described the collaborative effort?</p>
R9:	<p>Well, it is actually a very good question with a very broad answer, but I think that Intel—part of the company with the idea of a decentralized research effort, and part of it was because Gordon Moore and Andy Grove ran the Research and Development effort at Fairchild, and they had experienced first hand that often developments that were made in the R&D lab took years and years to transfer to the manufacturing, and consequently to the market place. Often it did not transfer successfully. So their thoughts were from the beginning, to tightly tie Intel’s Research and Development directly with the manufacturing and the marketing of the products, so as not to have that wall between research and development and the rest of the company.</p> <p>We are structured that way today. In fact, I would tend to venture and claim that Intel has a decentralized R&D approach as opposed to more of a classic centralized R&D, like maybe an IBM or a Bell Lab, even Microsoft. They have centralized research efforts.</p> <p>Intel’s is spread out. We work a lot with entities outside the company such as universities, other companies all around the world. We have probably 6,000 researchers within Intel that will blend between research and product development at different points in their career. So I think we are the largest and most successful decentralized R&D effort in the industry that I am aware of.</p>
Q11	<p>Some of this question may not be applicable, but in my past interviews, people have rolled with it. See what come to mind when I read this. Can you provide examples of the types of goals these resources are aimed at achieving? The resources I am talking about are the excess</p>

	capacity or excess human resources, or the people who are pulled into a new venture. It's kind of redundant.
R11:	The first thing you are assuming is that you have excess capacity, excess people, or what was the third category?
Q11.	I am not necessarily assuming that. I understand your answer from the beginning, that when there is no excess capacity, you just readjust priorities. So with that in mind, when people, I guess, are pulled from one project to pursue the new project or venture, are there other types of goals that arise from pursuing this new venture, or is it just a new entity?
R11:	<p>Well, the first and foremost is that Intel is a commercial entity, so ultimately the goal is that you are going to bring a technology through a product into the market place. People are going to buy it, you are going to make money, and that is going to be a benefit to your shareholders. So given that as a general assumption that this is going to be somewhat common for all commercial ventures, or it should be, or they are not going to be making money.</p> <p>The next thing is to try to have chosen something that makes a difference, something that matters, something that will have an impact, and that people are going to want buy, then to have effectively and efficiently as possible refine that technology and bring it to the market place.</p> <p>So we are not an organization that tends to do research and experimentation for research and experimentation sake. We tend to have to have a very specific goal in mind. All of our actions are driven to make that goal a reality, and ultimately that reality comes to the market place.</p> <p>If I can give you an example, the thing that Intel does is make computer chips. In order to make computer chips you have to be able put a pattern down on the surface of the chip, much the way a printer has to put ink of various types down on a piece of paper in order to either have text there or to form photographs, etc. So we put patterns down on silicon and connect them that they ultimately create transistors that allow us to get our work done. We currently use a type of lithography called deep ultraviolet light. Deep ultraviolet light is wavelengths of light that are shorter than the human eye can see. They tend to range from a high of about 253 nanometers and goes down to about 157 nanometers. Our current technology uses the middle spectrum there, which is about 193, and so the next generation 157, and after that spectrum of light runs out of steam there is no more wavelength in it. We as an industry, and we as a company looked many years ago at this, and could extrapolate out</p>

	<p>and see that if we couldn't find something to take the place after the 157 nanometer light source, that our continued rate of progress of shrinking the elements of a chip to finer and finer dimensions was going to hit a wall.</p> <p>We had researchers that recognized that the laser technology that at the time was being developed for the Star Wars Defense initiative to shoot missiles out of the sky might be redirected and used to print pattern on paper. The problem was that the wavelength of light was so tiny that there was no material it could pass through as a lens, so you couldn't focus it, and you couldn't put the pattern on it. So they also figured out that instead of going through a lens and through a pattern called a mask, kind of like a negative on a film, that instead you would have to use reflective technology and reflect off of a pattern, and there the technology that had been created for the Hubble telescope would come in handy. We funded to a tune of a quarter of a million dollars, this idea that we could take these two very different technologies out of the national lab and, in fact, make a commercial lithography machine out of it. That at the time was a glimmer in somebody's eye. This was in 1997. Today that technology is the #1 choice for the industry to adopt after 157, deep ultraviolet light, and we will see chips on the market using that technology probably in 2007.</p> <p>So not research for research sake, but taking ideas, trying to solve a problem, one that was an important problem, and then doing a lot of hard engineering and scientific work to make it happen. That's what our research team does.</p>
Q14	<p>Is there anything in your organization that gives your researchers or employees in general, time to pursue things that have not been adopted by the organization? I don't know if you are familiar with 3M having that 15% rule?</p>
R14:	<p>We do not have a 15% rule. There are skunk work projects that start within the company. The fact is that people here at Intel are not micromanaged. The culture of the company is that you sign up and you have a job to do, and you are obligated to get that job done. If you have extra time, and sometimes that extra time is not 8:00 to 5:00. Intel employees typically are not an 8:00 to 5:00 crowd. They will devote time and energy to pursue something of interest to them, and at a point in time where they think it has possibilities, they will bring it to management to seek resources funding, etc., and maybe they will drive their own job shift from what they doing to pursuing their new idea. We do have some formal programs to encourage internal entrepreneurship, in the sense that, again, somebody has a great idea, and we give them the resources and the time to go pursue it in depth. A lot of those early</p>

	<p>germinations of ideas are done as people catch an extra hour here or there, or they just flat out devote an extra hour here or there until they can develop it into a factor that is worthy of taking and seeking a more formalized kind of backing. So we don't do it as a 15% rule, but we do it as a culture.</p>
Jason	<p>You had alluded earlier to additional people being hired sometimes, experts being hired. Can you elaborate on that some?</p>
Intel:	<p>Yes. If you are pursuing a number of opportunities, there is a certain point in time where you say the amount of work that needs to be done to properly pursue a given activity, is going to require more resources, or more people being pulled away from other important projects than is smart. So, what a company will do is hire.</p> <p>If you are hiring, then what you are looking to do is hire people with the education, the skills set and the experience that will help you achieve your goal. So, like any organization we will hire additional people that either have a skill set that we don't have, or they have a skill set that we have, but we just need more of.</p> <p>If you are trying to design two or three generations of microprocessors and you want to get them to market in a certain time frame, then you can either put enough people on it to get it done, or you are going to fail to hit your market window. So you go out and hire more circuit designers, and more electrical engineers, and more people who have the skills that you need to bring that product to market. That is kind of what companies do.</p>
Q17	<p>The next question is concerning the stakeholders. Do they ever balk at the excess resources that go into the skunk works, or the formal programs---anything like that?</p>
R17:	<p>Not in the way that it is described there. The way that a stakeholder is going to get involved, is if you have a skunk work, by its very nature, that is going to try to steal a little bit of resources below the radar screen to go pursue a different idea, but it means that still the bulk of the resources are tied to a given effort or project that is being done. If at a point in time that resource strain hinders the main project from being done, or being done on schedule, or being done to the quality that it needs to be done, then stakeholders will chime in. They won't chime in, in the sense of saying that skunk works thing, they will chime in saying our project is behind schedule, our project is below its target, our project is not meeting what it is supposed to do. What will happen often, and you will go through phases on a big complex project, you will go through phases where it is ahead of schedule, behind schedule, things</p>

	<p>look great, things don't look so great, etc. Typically when things aren't looking great, the people on the team will refocus their attention and energy to try to bring it back to snuff. That is the responsibility of the management over that project.</p> <p>The stakeholders will observe and complain if necessary. Management and the team will refocus. They may in essence put a skunk works thing on hold a little bit as they go into a very heavy and focused time, and they will try to bring that project back either on schedule, or ahead of schedule, depending on what they need. As long as everything is running smoothly, and your project is doing well, is on schedule, and is meeting all of its specifications, you're are not even going to notice that some little skunk work thing is going on. The very nature of a skunk works is that people outside of the core group that are doing something don't know that it is going on. It is not widely publicized.</p> <p>Gordon Moore has this saying, and it is very true in science. Again, it is a company of scientists and engineers, and the approach is that if you are not failing you are not trying hard enough. So you have to know that for all of the various ideas that you are going to at least pursue, there is a high degree of failure in them, because that is how you learn, then you can improve, and ultimately you will be successful. If these things were obvious that it was needed, and obvious on how to solve the problem, somebody would have done that a long time ago.</p>
Q19	<p>On these projects, any project, research and development, how, and how often does the firm determine the number of resources to devote? You have touched on that some.</p>
R19:	<p>I think there are a couple of answers to that. There is the answer that says you are constantly as a management entity reviewing the amount of resources needed or not needed, and readjusting within a bigger group. So you may have a big engineering group, and readjusting within my group. In running Press Relations, I may take somebody who normally is assigned to a given product line, and for a couple of weeks or a month or something, pull them off and do something else, because I need more done on this other thing and that other project that is kind of in a lull. So that happens on a day-to-day basis.</p> <p>On a formalized basis, you typically go through a formal planning process once a year. It is accumulation of a number of different meetings and plans and such. From that, you will get your broad assignment of resources, your budget, and things like that.</p> <p>Typically what happens on the bigger projects is that when you started out, while it gets refined year to year, the funding and the expectation is</p>

	<p>really a multi-year effort, because that is how long it is going to take to get the work done. So you do not go back to kind of zero-based budgeting each year, but you do adjust and fine tune, again, based on whether the opportunity is growing or shrinking, whether the project is ahead of schedule or behind schedule, kind of you will make adjustment. Then on a day-to-day basis, you will do that based on what the manager needs, and where he thinks the best use of his talent is at any moment in time.</p>
Jason	<p>Then you touched on the measures to determine the effectiveness of the allocation of resources. Is this based on you talking about whether or not it was meeting the time line, and things like that. Is there more?</p>
Intel:	<p>There are a hundred things. It really depends on the project, but if you are talking about something as complex as bringing a new microprocessor to market, or bringing a new factory to bear. We just opened a factory yesterday, \$2,000,000,000 to build this factory. It is about 18 to 24 months just to get the factory ready to open. This thing has to be 100,000 times cleaner than any surgical operating room. It has hundreds of pieces of equipment that are precision down to levels that are several thousands times finer than the thickness of your hair. It has cleanliness in it that is equivalent to one piece of dirt the size of a pea and 3 cubic miles of air. It has 1000-1200 direct employees who are building the most complex devices ever built by mankind. All of that means there is a lot of measurements and a lot of details that have to happen all along the way to get it open, and once it is open, to have it producing the product that we want to, and quality and yield that we want to.</p>
Q22	<p>Is there any incite on projects, skunk work projects, projects in general that have failed, and why they may have failed, concerning things like organizational design or even limited resources?</p>
R22:	<p>Yes. I can give you one that is a good idea, but did not work out for us, which was about five years or so ago when the internet was very hot.</p> <p>We formed a business in web hosting. Web hosting is these big machines called servers that hold all the material, and when you go out to click on a site on the internet, that is were the ultimate query goes, and the response comes from these machines. These machines are typically complex, pretty expensive, and they improve at a fairly rapid rate, so big companies will tend to host their own. Small companies tend to have a problem because the price of the machine is high. They may not be able to afford that. The expertise to keep then running without fail 24 hours a day, every day of the year, may be a level of sophistication that they don't have, and it is not core to their business.</p>

	<p>Maybe they run a car dealership, or they run a retail outlet, or they run flight reservation service. Running a server and keeping that website up to date and online 24 hours a day, 365 days a year, is something that is necessary for their business, but it is not core in terms of their expertise. So often they will hire that out, and we opened the business to have people to hire us to run their IT department.</p> <p>We have a huge complex IT Department within Intel, so we felt we had some expertise. We sell a lot of our products into these servers, so we felt that we not only knew a bit about them, but also that we could learn from running the business, how to make our products better. So there were all kinds of justification to do it, and we built facilities and invested money to do that.</p> <p>What occurred was that the .com boom went bust, and consequently the people who had these ideas and had these monies to in essence hire these services, went bust with it. The companies that were big enough, and for the most part traditional companies, like a Ford Motor Company, were big enough to run their own, so they did not hire it out, and the companies that weren't were small enough that they went belly up. So we, along with other companies that were pursuing that kind of business, found that we had a lot of resources in terms of people talent, a lot of money in terms of capital tied up, and not much business. In that case you either sell off or close that business, and readjust the resources to a place where you think you have a better opportunity.</p>
Jason	Well that concludes the formal questions. Thank you for your flexibility on some of those. Do you have any parting thoughts?
Intel	What is the class?
Jason	Actually this is a thesis effort concerning putting the entrepreneurial mind-set and innovation, that type of culture, into the Department of Defense.
Intel	<p>I think that one of the challenges that you face in that kind of situation (I'm a military brat growing up, so I have a little bit of understanding of the military) is you have a whole string of dichotomies.</p> <p>The effective ways for military to run often are with tremendous precision and discipline without probing or questioning orders, and without straying and free lancing much from what the strategy is. Yet, at the same time, the mere definition of entrepreneurship tends to push at the very core and edges of everything that tells us traditionally, makes a great military operation. So I would look, for example, in business where similar phenomena occurred, especially ones that have been successful, then to see if those structural elements of success are</p>

	<p>applicable to your circumstance or situation.</p> <p>So, as an example, I would tend to say that our factories, the complexity of the product we are building, the volume of the product we are building, the high capital cost of what we are doing—all of these things will tend to be best utilized with a high degree of discipline, with very little variation from the specifications, etc, etc, etc, because you have to build this very complex thing. If you don't, if you screw it up anywhere along the way, as it goes through its hundreds of manufacturing stuff, this doesn't work. So it has an environment that would tend to, I think in general, map closely to what the larger sense of the military and the defense department would require or need, but at the same time, we are changing our core process technology. The recipe we used to build chips—we are changing it every two years, because we are shrinking to finer and finer dimension. We make a billion devices, and thousands of different products over the course of a year, so there has to be a way to institute change, and also to create an atmosphere of discipline, or innovation with discipline, rather than just discipline alone. Those would be the kinds of places where I would look to see where the defense department might learn and adopt some of the techniques and tools from industry to improve their situation.</p>
Jason	<p>Great! Thank you very much for your time. I will send you that stuff on the e-mail. It should only take you about ten minutes to do, and if you can get it to me within the next week or so that would be great. Also, if you have any other thoughts you can just send me e-mail on it. Thank you again.</p>
Intel	<p>O.K. Good luck. Bye</p>

Appendix H: Kone Interview Transcript

Interviewer: Lieutenant Rochelle Smith

Date: 25 October 2002

Rochelle	I appreciate you taking the time to talk to me, and I will try to be quick. First, who is your supervisor and what is his job title?
Kone:	My supervisor is the Director of Corporate Communications and Industrial Relations.
Rochelle:	Wonderful. I was trying to see who the entrepreneurial people are, as for their rank in the company?
Kone	Well he isn't one of them, and neither am I, but I'm supposed to tell you something about them.
Rochelle:	So you're the one who has been chosen for today?
Kone:	Yes. I've been chosen because I've been in the company for 20 years and spent most of my time traveling around it, meeting people and talking to them, in order to report on what they are doing. I have also, in the process, kind of become the Custodian of Corporate History and Culture, but not because I am an entrepreneur.
Q1:	What caused your company Kone to pursue entrepreneurial ventures or new innovations?
R1:	<p>I'll give you two different kinds of answers to that. What I would see as being one of the interesting entrepreneurial natures of the business is that Kone is over 90 years old. It was founded in 1910, and until 1968 it was basically a little domestic Finnish company. From 1968 until the present, it has grown by leaps and bounds through the acquisition of other, basically elevator companies around the world. So we ended up being a global company, but was made up of companies that had originally been small national companies like ourselves, or in some cases we bought, for example, Westinghouse's European elevator business, which was quite large and part of somebody else's large multi-national operation.</p> <p>What happened was that the small Finnish company did not have the resources, the experienced, or even probably the will to try and integrate all those companies into some kind of consistent way of working. For 30 or so years, that multi-national organization ran as a federation of local companies. What that had to do with entrepreneurship is that basically the local managing directors were treated as entrepreneurs within a large company structure.</p>

	<p>So, they had some requirements in common, but for the most part, they were allowed to keep even the old company name, and they were pretty much told, you run the company, and if you make enough profit you will be rewarded. They were rewarded on a bonus system over their salary, depending on how good their financial result was. They were encouraged to act as local entrepreneurs.</p>
Rochelle:	<p>Was that for the first 30 years?</p>
Kone	<p>This was until very recently. Kone's attempt to manage the whole thing centrally as a harmonized global operation, is really about four or five years old.</p>
Rochelle:	<p>So, especially with Kone, what changed the mind set from one of, "we have all these entrepreneurs, and as long as they make a profit they can do what they want to?" Now we are going to try to manage them?"</p>
Kone	<p>A number of things that basically the global environment changed, for example, in Europe where Kone was doing 2/3 to 3/4 of its business, the European union's standardizing of norms and legislation made it possible for companies to sell the same product and the same service across borders, and it became a liability to be doing national-based business against competition that was doing European-wide business. The European-wide product and services were being offered at much greater efficiency and lower cost, than could possibly happen on a country-by-country basis. For example, in the days when I joined Kone we had factories inherited from all these companies that we had bought—in almost every country of any size—because the customers in those countries wanted to be able to go and kick the tires at the factory. They wanted to feel that they could get a local product. That is clearly no longer the case, and in an increasingly global economy, people want a product that they know has proven itself. So many of our customers now are operating across borders; they want the same product, wherever they are ordering it. So, they are not at all interested in all these local differentiation issues that were used as really protectionist measures in the old days.</p> <p>So there have been all these pressures for standardization and globalization, which have undermined the ability of companies such as ours to work as a federation of local entrepreneurs, and they have encouraged the companies to come up with highly streamlined, homogenized approaches to doing business that can be replicated easily, and at low cost, from place to place.</p>
Q2:	<p>So what was the key challenge then for Kone as they moved from one to</p>

	the next?
R2:	How to maintain the spirit and initiative that the entrepreneurship had created among local company leadership, while taking away some of the natural incentives and rewards that made that happen.
Q4:	So would you say that the organization as it existed before you became the new global Kone was designed for that?
R4:	<p>It ended up being that way. I'm not sure it was designed that way, but it was almost by default, because we inherited this company.</p> <p>The elevator business is only now 150 years old. Basically it dates from the time of the civil war when Elisha Graves Otis invented the safety gear and made it possible for people to ride in elevators, because if the cable breaks the elevator does not fall anymore, etc. That was from 1851, I think. So what happened at that point was because the technology was really very simple- just a motor and some buttons, and it went up and down. Engineers in every country could say, "I can do that", and start an elevator company.</p> <p>Then because people were riding in the elevators, the local government began making safety rules. The safety rules became protectionist rules. We find in the states, even from state to state, the norms and standards are different, and it became very, very difficult. Every place that made laws ended up eventually protecting one local elevator company. So it became natural place for young engineer entrepreneurs to get started, and then they handed the company down to their sons or daughters, and maybe to their grandsons or granddaughters.</p> <p>Then this great consolidation process started, where the Otis's and Westinghouse's, and in Europe the Schingler's and the Kone's and the people began buying up all these little companies because by the third generation two things had set in; one is that the third generation, the grandsons and granddaughters and entrepreneurs usually turn out to be spoiled brats, because they have a good time with their grandparents that they inherited. Then number two, we were getting into a completely new era of technology, and the second half of the 20th century computerization came into the elevator business, and companies that did not invest in that early suddenly found themselves way behind, and the investment that it would have taken to catch up would have drained all of the value out of these little, tiny companies, so instead, the grandchildren or great grandchildren said let's take our money and run, and sold out to the Otis's, and the Westinghouse's that were going around with their pockets full were buying them up. So that climate changed completely.</p> <p>On the other hand, there is still a very interesting entrepreneurial part of</p>

	<p>the industry, which probably will never die, and that is, that the really interesting and profitable part of the elevator industry is the service part—the maintenance of equipment. What happens there-- as opposed to this very heavy investment that is required in the manufacture of new equipment, and the investment in the latest technology, and it's how you get your printed circuit boards, and what kind of control system or software you develop, and things like that--the service business was basically fairly uncomplicated.</p> <p>What happens is that an Otis or Kone trains young men mostly to be elevator mechanics, and they learn first how to grease and oil, then how to replace some parts, and eventually how to troubleshoot even the most complicated system. At some point, almost every one of these mechanics admits to himself</p> <p><i>(tape cut off here so question 5 response is based on Rochelle's notes)</i></p>
Q5	What were the expected benefits that compelled your company to strive to be more entrepreneurial?
R5	Kone was the first Finnish company to go international. They were originally not ready to take control of others. Kone had to change its mindset to be a more formal leader. There was no one to tell the company what to do. Kone makes a great deal of its money in service. Kone had loyalty of customers. Their mechanics often become successful entrepreneurs and are bought out by the same company. These mechanics often have little to no formal education.
Correction	<i>(tape was cut off right before this question and Kone had to be called back)</i>
Q6	Does your organization have a reserve of human resources available to pursue new opportunities on short notice should they arise?
R6:	To human resources, maybe that's always the case every place, but right now it certainly feels like a situation where we have too few people doing too many things, and every company seems to be doing that. I mean that's the nature of the competitive environment at the moment.
Rochelle	So you don't really have reserve resources--you're running thin for resources?
Kone	No. It is not one of those questions I'd like to answer yes or no. It depends on how you look at it. As I said, we have a hierarchy of resources. It seems to me that the accurate answer to that question is that, for example, four years ago, before the stock market began going into its nose dive, every single talented young person in any company, any place

	<p>in the world, knew he could walk off the job and get a better job the next day, and people were doing that. Nobody had a reserve of any kind. It simply did not exist in industry as far as I can see.</p> <p>I know in Finland for example, Nokia, the telephone mobile phone company, was able to absorb every single graduate engineer, and every single graduate economist from all the universities in the country every year, so nobody had any reserves. We were all desperately struggling to get good people. The situation has changed a bit today. A number of companies have laid off people, and it is a little bit easier to get people, but nobody is hiring people into reserve, as far as I can see. There are trying to keep it as thin as they can because the profit environment is not very strong.</p>
Q8	So when you do have reserve resources, what type of jobs are those people in?
R8:	<p>Again, I am not sure that such a category exists. I am trying very hard to think of what I would imagine reserved resources look like. I can tell you of a situation where things like that do occur.</p> <p>The elevator industry is by nature quite cyclical, because what we call the new elevator part of the business is the new equipment part of the business, because you can only sell new elevators and escalators if people are building new buildings. Nobody buys them to put in their yard or anything like that. So because the construction industry is cyclical, regarding the installation of new equipment, our cycle is about a year behind the construction industry cycle, because you can't put your elevator in until the building is already going up.</p> <p>What happens is that in boom times you hire as many great installation people as you can, because you can usually get more work than you will actually have resources to do. Then when the bottom falls out of the market, you have all these people with skills that you know you may need in three, four, or five years, but you can't use them right at that time because you have very little new construction. Therefore, you try to put them into parts of the service business, modernization business, where you can keep them going until you need them. The situation is a little bit different than in the states, because in the states you have to hire people out of the union hiring hall. In Europe, the people are on the company's payroll directly. So it is a little bit different, and in Europe it is a little easier to hang on to those people. That's one of the areas where sometimes we will try to keep people on the payroll, although maybe the immediate need for them is not very large.</p>
Q11	If you were to do that, what would be the goal for keeping them? Would

	it be just so they could do construction, or would there be other goals in mind?
R11:	The goal is that these are people with definite skills that are needed both in new elevator installation, and can perhaps be used in things like major modernization projects, and we know that we are going to need them again in a few years, so we are trying to stockpile them in a sense, to have them when the next construction boom comes along, so that we don't find that we are losing jobs because we have no skilled people to do that. You can't just hire somebody off the street and tell him to go and install an elevator. It is a complicated business.
Q14	When is the creative capacity being innovative? If you do have extra people, how much time do they spend being innovative—a percent of their time, like 15%, or one hour a day?
R14	<p>That's the kind of thing that people like to have to put in their research projects, but it doesn't make any sense in real life. It depends an awful lot what we are talking about. If we are talking about people in the research and development part of our business, then presumably you are spending 80% of the time being creative or innovative, and 20% of the time writing reports. If we are talking about people in the installation part of the business, they are probably not spending too much of their time being very innovative at all. They may come up with some things along the way, but certainly in terms of the time they spend being innovative, I would say it is very, very small. But then, there are other parts of the business that require a lot of it. Those are the troubleshooters, and the major modernization people at the technical end, there are sales people, and some of the people in the management positions who are trying to figure out ways to outsmart the competition. So those people are hopefully spending a lot of time that way.</p> <p>Kone does not have lots and lots of manuals that tell you how to run your business. Most of it is going out there and engaging in the work, and trying to do it better than anybody else, so entrepreneurship in that sense is fairly high. Our creative work is fairly high. In a strange way, the elevator business always was a business that attracted fairly entrepreneurial people because, as I said, you would go out by yourself, or with a partner, and would be faced with a new situation in every building you went into. What's wrong, why is it wrong, what can I do to fix it, or nothing is wrong, but I'd better check the system to make sure that nothing is going to happen and break down before I come back again.</p> <p>I have heard time and time again from these people, and they make up more than half of our total workforce of 23,000 people, saying what I</p>

	<p>really like is the job is always different, and there is nothing routine about it. Every time you go into a new job, you've got to listen to what the people tell you, and see what you can figure out. It attracts people who like to do that, rather than be told by someone this is what you have to do now, please go and do it.</p>
Q19	<p>How would Kone determine the optimum amount of creative capacity, so if you do have the amount of people you want, how would you determine that?</p>
R19	<p>I have never heard anybody say the problem here is that we have too much creative capacity—like people are trying too hard to come up with new things, they should all go back and just kill off a few brain cells, and do things that are a little more their way.</p> <p>I said to you that we are moving in a direction of doing much of our business in a more streamlined and harmonized fashion, so we have kind of been looking for optimal ways of doing certain things, then we are asking people to accept those ways of doing them. I guess we are saying that we have reached a limit, in that we don't want people to reinvent the wheel on everything that we are doing.</p> <p>I can't make too much sense out of the question as to what would be the optimal amount of entrepreneurship. I understand entrepreneur to mean a person who says I am treating this as if it were my own individual company—my little piece of the business, whatever it is, whether cleaning the floors in a factory, or being in charge of the sales team for the whole country. I have never heard anybody say (nor do I think anybody would be likely to) that kind of spirit hurts anywhere. I think everybody would like to have an extremely self-motivated workforce from top to bottom. I don't quite understand where they would want to limit it, except to the extent that they probably would not want people to say, if we have a wheel that is a really high performance wheel, we don't somebody taking a huge chunk of stone and spending a lot of time starting to chunk away at it with a hammer and chisel to make a stone wheel that will never be that good.</p> <p>You do need to accept the tools and methods that have shown to work as the basic things we are working with. We have done a very good job of developing those things, but now we would like our people to take them and treat them as their own tools and go out and be very, very motivated to out-perform the competition.</p>
Rochelle	<p>Thank you for your time. I actually don't have anymore guided questions. I did send you e-mail with some questions that can be done</p>

	<p>over e-mail, and they are numerical assessment questions, with a 1 to 5 scale, and you can choose. Some of them may not apply, especially with what you have described for the majority workforce. It sounds like they are doing very hands-on individual activities, as opposed to a team, but in a larger sense. Just leave blank those that do not apply.</p>
Kone	<p>With all these things it would be much easier for me because in a company as large as we are, our service people, in India for example, most of them are illiterate. They are really hands-on people, because they are not even able to take a manual home and read through it. At the other end, we have people doing research in very, very advanced technologies, and creating real breakthroughs, and are about as far away from that profile as you can get. So it obviously would be easiest for me to give useful answers if we were talking about a person in this situation in this environment.</p> <p>It is very difficult if you are asking me, as you have often today, how much time does a person spend being creative, I do not know what that means when I am comparing a Ph.D. sitting at his computer with the most advanced three dimensional designed software, comparing that person to an apprentice on an installation site whose main job is to hold things in place while somebody else bolts them together. It is very hard to give useful answers when you have such a range of activities going on.</p>
Rochelle	<p>I'm sorry about that. That has been true with our study, that depending on the industry and the type of work that people are doing, some of our questions are difficult to answer, and we are trying to refine some of them, but we plan on applying them to the Department of Defense, and that is very varied. There are lots of organizations within that who are similar to what you are describing in Kone, where we have a wide variety of skills and types of jobs that are being done, so we are trying to be broad with it, but at times that makes it confusing and we are working on that.</p>
Kone	<p>I would recommend in some ways your breaking it down, because within our company, as within your activities, you could give much more useful, and get much more useful results, I think. For instance, if you said well, what about the people who are doing the work at this level, what about the people who are doing it at a different level, what about your middle managers-how do they do, what about your top technology thinkers-how do they do it, what about your top business managers-how do they do it, what about your ordinary sales people? So try to determine certain levels, because I think the differences are not so much within companies. Certainly the differences within Kone are bound to be greater than they are among people doing similar types of jobs in the industry from company to company. So if you really want to know, say, how Kone</p>

	does something different or better than the other elevator company, then we would have to get very specific about jobs were are talking about.
Rochelle	Thank you for your input, because for the thesis research that I am doing, I'm hoping to have a follow-on where someone else will be continuing my research. Those are the sorts of things I would want to be able to tell this person these are the things to look out for because some of these questions you need to specify more. Some things I'm afraid we missed in our study because the real world is so complex that as we simplify, we miss things.
Kone	As I said, I know looking at the two examples I just gave you, the entrepreneurial quality of those managing directors and presidents of the companies, the subsidiaries from country to country, that's not very typical of some of our competitors, but the notion of the well-trained mechanic going off and starting his own business is endemic in the industry. Whatever big elevator company you go to, you will find that they will complain that they lose a certain percentage of their best field people to their own startups. That's just the nature of the business.
Rochelle	I thank you very much for all of your help and answers that have been very well thought out, even for some difficult questions as far as the clarity of the questions. I appreciate your time, especially since you are not at work, and still working.

Appendix I: Mobil Interview Transcript

Interviewer: Lieutenant Rochelle Smith

Date: 7 November 2002

Rochelle:	My first question is what is the job title of your supervisor, or their position?
Mobil	Vice President, Business and Product Development.
Q1	What caused your company to pursue entrepreneurial ventures or new innovations?
R1	We made a decision to do that as Mobil Oil, probably six or seven years or so ago now, because we needed to differentiate ourselves to the customers, the customers being the motoring public, to give them a reason to want to shop at Mobil versus other choices they may have. One of the initiatives was this concept of speed, which turned out to be the Speedpass initiative. It was one of a couple of major initiatives, but the primary reason was to differentiate ourselves, and to give customers a reason to want to shop with us versus our competitors.
Q2:	Can you describe the key challenge that was faced regarding this venture or innovation?
R2:	Probably getting the entire organization to buy into it, then to actually go out and implement and execute the entire concept once it was developed, because it was a small group of people who had developed it, and those people really were not going to be responsible for implementing and executing. So you then went down to the field organizations, of which there were several. It became the responsibility of theirs to buy into the concept, sell it to the operators that actually run service stations, and additionally ask them to pay whatever the time and cost was to install certain equipment, and to institute the program.
Rochelle	So they had to pay on their own in order to do that. There was a fee involved to participate?
Mobil	A fee is not the right word. Really, there was an equipment investment to be able to accept Speedpass. It was not an ongoing recurring fee. It was just an equipment investment in order to accept Speedpass.
Q3:	What were the barriers that had to be overcome to accomplish the challenge?

R3	I think I kind of did that in the last answer, and perhaps they can be put together if you can. I think the barriers were, again, convincing everyone that this made good sense, and therefore, their enthusiasm to sell it to the operators of the individual service stations, and the expense barrier.
Q4:	Would you say that Mobil, as it existed at the time the venture kicked off, Speedpass kicked off, was well designed for Speedpass, or were there changes to the organizational design that were required?
R4	There really weren't true changes to the organization in the sense of having to realign the structure of personnel. Clearly there was probably an individual or two in each one of what we call our field business units. One of their primary objectives and goals was managing the Speedpass brand, but they were not major changes to the organization.
Rochelle	There were just small changes that needed to be made for implementation?
Mobil	From an organizational standpoint, that is correct.
Q5:	What were the expected benefits that compelled Mobil to strive to be more entrepreneurial?
R5	<p>The first one was to differentiate ourselves from our customers. There had been many, many years in the oil industry whereby oil companies were kind going at one another in two major ways. The first one was actually putting the price of gasoline on a sign at the curb, if you remember back then, and today, there are no businesses that do that. You don't really think about it until it is actually presented, but no one does that. You don't drive by a fine restaurant and have a price out there for a lobster dinner. So companies would compete from that standpoint.</p> <p>Companies would also tend to advertise and promote all of the additives and ingredients that their fuel had that perhaps others did not. Really what it came down to was the customers really weren't buying into any of those things anymore, and they realized they could get the product anywhere, and I think to some extent, were convinced that gasoline, at least from a major oil company perspective, or a branded perspective—the Exxons, the Mobils, the Amcos, the bigger name ones, were all pretty good gas, or they would not be in business.</p> <p>We determined we needed to do a number of things to differentiate ourselves in the eyes of the consumer in speed and convenience, and</p>

	<p>Speedpass fit the bill for both of those. The other element of Speedpass that was a major benefit to us was the ability to begin to understand who our customers were, and evaluate some of their buying patterns, reward our better customers, and entice them to come back. So Speedpass is much, much more about marketing than it is about technology.</p>
Q6	<p>Does your organization have reserve human resources that are available to pursue new opportunities on short notice, should those opportunities arise?</p>
Mobil	<p>Are you going back now again? We have been kind of talking about how this was deployed as a part of Mobil Oil five or six years ago. Is your question along those same lines, or more in today?</p>
Rochelle	<p>It can be either, whichever one applies to you now. We are basically trying to figure out if entrepreneurship is going to work for us, do we have to have group of people who are sitting around thinking up new ideas, or how have other companies or other places done that?</p>
R6	<p>Today we are structured completely differently than we were when this was launched. We are a small organization called Speedpass Network, and we are wholly owned by Exxon Mobil, although we do operate in a separate functioning unit, and we are growing the Speedpass brand with other retailers. For example, all of the McDonald's restaurants, 440 of them in the Chicago area, have been accepting Speedpass for a year. We will be launching Speedpass at a grocery store chain in New England starting in December or January, and we continue to expand to other retail channels that make good sense, and where customers want to be able to have the convenience of using Speedpass at other retailers. So, we do operate separately today in terms of functioning from that standpoint—that is all we do is focus strictly and specifically on Speedpass.</p> <p>Depending on how you define quickly or rapidly, most of what we do requires us to hopefully have some speed to market with it, although I am not sure it is a type of business where you are managing crisis situations. I would not say it is really that.</p> <p>The other answer to your question, should there be some people whose responsibility it is to be thinking about whether it's building a new rocket, or coming up with a new product idea in our business, whatever it is, clearly,</p> <p>I would say you need some people, probably not too many of those people, but I think someone whose responsibility it is to determine where you are going to take this business over time, and how you are</p>

	going to get there.
Rochelle	So you need them, but you don't necessarily have them right now?
Mobil	We do have individuals who are responsible for shaping the future of Speedpass, what our product line will look like, and strategically where we are going to go. We are clearly staffed today to do that. Our organization, as with all organizations, as we add more retailers such as a McDonald's and a grocery chain who accept Speedpass, we will need more individuals to assist and manage the implementation of that. We probably won't need a significant amount of additional people who are actually developing the ideas of where we are going to take the business.
Q7	So right now, what is the nature of the reserve resources you have right now? Where would they be, and what kind of jobs would they be doing right now?
R7	<p>Within our organization we are structurally in long links against five or six business lines. One is product development, which is developing the future of Speedpass; for example, can I use it over the internet some day? Today it is just a little barrel-shaped transponder—should it be a Mickey Mouse transponder? What is our banking relationship along the product lines with credit card companies, and those things? That would be product.</p> <p>Then there is business development, which is what I am responsible for, and that is determining the strategy and how we want to grow this business with retailers or others.</p> <p>We then have a retail services group, and they support all retailers that accept Speedpass today.</p> <p>We have an operations group that kind of supports a lot of the backend type things—we have a 24/7 customer care center, anything to do with operations, really from assistance and technical standpoint.</p> <p>We have a whole marketing organization which provides best practices and support of retailers that accept Speedpass today.</p> <p>It's kind of how we were aligned, and again, we may tweak or change that over time, but currently that is how we are aligned.</p>
Q11	Can you provide examples of the types of goals these resources, or these people are aimed at achieving?
	I think the biggest one is just to kind of define the vision for Speedpass

R11	<p>in general. Everyone as a team works together to get to that. The major objective is to continue to provide speed and convenience, and a better buying experience for customers. The way in which we do that, by providing products and backend type information to retailers, McDonald's, Exxon, Mobil, can make the buying experience meet those criteria for customers.</p> <p>Let me give you one example. At the grocery store chain that we'll be launching-this will be available to all retailers-you'll be able to wave your wand at the register. Not only will that just have paid for your purchase, that also would have just provided you with any discounts or loyalty points that retailer's program has, in place of, for instance all those cards you carry. Those will be eliminated with Speedpass, multiple credit cards. It will all be embedded for lack of better word, into the wand.</p> <p>Everything we do here is to make the customer's buying experience faster, easier, and better, and to try and increase profits for the retailers that accept Speedpass. Everything, all those business lines that I described to you before, everybody works in unison to meet those two real major objectives.</p>
Rochelle	<p>So for Mobil, you had mentioned that before I was different, so has the firm always had extra people, that if you have a new idea, like Speedpass, you could move them into that.</p>
Mobil	<p>No, and even today, because we are owned by Exxon/Mobil, the organization has just found a way to staff this. We are in the same mode as every corporation in the world, and that is we are reducing the number of people, not increasing them. So no, there are no extra personnel, if you will, lying around. I think it just forces you to determine what's the most important objectives you have as a company, and put the resources behind that, and don't do the other things you are doing that we don't really need to do.</p>
Q14	<p>There are a few more questions that I was going to ask, and some of them might not apply, but I will ask anyway. So when are your creative capacity or your extra people being innovative. This could be in a one hour a day, always, or 10% of their time?</p>
R14	<p>Probably not applicable.</p>
Q16	<p>How was creative capacity or the extra people that you are not sure that you have, but if you didn't have them, how were they brought into the company. For instance if you had hired new people specifically to be</p>

	innovative, or to help with Speedpass, did you hire all of them at once, or did you hire one per year?
R16	It really was on an as-needed basis. I would say we are staffed with about half that are existing employees from Exxon and/or Mobil, and the other half of our staff are from individuals who came from different backgrounds and different organizations. So we actually, in some senses went out and hired the experts, if you will, as opposed to trying to figure it all out on our own.
Q19	How does Mobil determine what the optimum level of people are that you would need in order to have something like Speedpass get off the ground and do well?
R19	That is almost impossible to answer. I think as you put your strategy and vision into place, you then start implementing that strategy and vision, then you clearly have an idea going as to how many people you think you need, and hopefully you are close. We are almost really taking to a new level this whole concept of electronic payments and identification, so there are a lot of parts of our business that we are doing that no one has ever done before. So, I am not sure, in all senses, we know, and I would guess with any other company that you will speak to, particularly like true entrepreneurs who started a business from scratch. We did not really do that. We started a new concept in a new business line, but we did it with the backing and support of a pretty large profitable organization. Some other people you will talk to can probably really give you the blood, sweat, and tears that we would like to say we can, but quite frankly we were backed by a pretty big company.
Rochelle	Actually, that is the last of my questions that I have for interview by phone. I do have a few questions that are numerical assessment with 1 to 5 answering scale, and you would circle one of those. I can e-mail those to you, or we could do them over the phone, whichever you prefer.
Mobil	You can just e-mail them; that would be easier.
Rochelle	O.K., I'll go ahead and do that, then you can send them back to me. If you have any questions or if they don't apply, you can leave those blank, or e-mail me back.
Mobil	O.K. Very good.
Rochelle	Thank you so much for your time. I do expect to finish my thesis in January. If you are interested in seeing my results, or have questions about what I am writing, please feel free to e-mail me, or call—either way. Thank you again.

Mobil	Sure, and good luck.
--------------	----------------------

Appendix J: NCR Interview Transcript

Interviewer: Captain Jason Whittle

Date: 21 November 2002

Q1:	What caused the company to pursue entrepreneurial ventures or new innovations?
NCR	What?
Q1	The first question, what caused the company to pursue entrepreneurial ventures or new innovations?
NCR	Are you referring to procurement or what?
Jason	We are referring to the organization as a whole.
R1	Numerous things. Board of Directors, research on best practices
Jason	All right. What was the goal of these?
NCR	To bring best practices in-house.
Q2	Ok. Describe the key challenge that was faced regarding this venture or innovation.
R2	Overcome the “not invented here” and just organizational inertia.
Q3	Ok. Describe barriers that had to be overcome to accomplish the challenge. You touched on that in the last one. Do you want to elaborate?
R3	You must find resources and time.
Q4	Ok. Would you say the organization as it existed at the time the venture kicked off was well designed for the venture—or were changes to the organization design required?
R4	Changes were required.
Jason	In what way? Or, is that constantly evolving?
R4	Pretty well constantly evolving. To make various roles and responsibilities throughout the company to align with new initiatives.

Jason	All right. New initiatives are the best practices and those kinds of things?
NCR	Yes
Q5	What were the expected benefits that compelled your company to strive to be more entrepreneurial?
R5	Profitability.

Appendix K: Shell Interview Transcript

Interviewer: Captain Jason Whittle

Date: 5 December 2002

Jason	How are you? Do you have about 30 minutes?
Shell	Yes. How are you?
Jason:	I'm good. Do you have an e-mail address where I could the short questionnaire to you later, and what is the position and job title of your supervisor?
Shell:	My supervisor's title is Technology Manager.
Q1:	These questions may not be directly applicable, but if you need to qualify them in any way, just verbalize that if you could. Some of the stuff comes from wanting to know about the game changer, but some of them are also general questions. What caused Shell to pursue entrepreneurial ventures or new innovations?
R1:	It's the recognition that innovation is one of the important characteristics of growth in top line, and growth into markets where you are already playing, and growth into markets where you may begin to play, and growth into markets where you may just like to play. Lets say it is the recognition of the need to intend further growth.
Q2:	Describe the key challenge that was faced regarding this venture, or ventures in general, or innovation.
R2	The key challenge is what is called the innovator's dilemma. I think we buy the basic idea that Christenson has that in innovation you are generally dealing with acceptability criteria, and those criteria being based upon support of existing modes of operation. Perhaps existing business models and so the difficulty is to be able to maintain the output from the innovators into commercial practice. That's the major total owing innovators and . It is called the value of death, and the value of death is one of the terms used in the literature now. It is one that we do quite a bit of work around.
Q3:	O.K. I'll look into that. Describe the barriers that had to be overcome to accomplish the challenge.
R3:	Thought barriers involve communication. Communication assessing what the political landscape is, assessing what the barriers for nurturing

	<p>might be; in other words, if you have something which cannot be articulated immediately, as bringing value within the current strategic constraints, then you might find that the way to go is to build a kind of a nurturing environment. That is sort of one of the ideas in game changes. We provide a sort of nurturing environment, and we help to provide the basics for political mapping. In other words, to help identify those constituencies which should be brought on board to either address their concerns, or to get their support to address the concerns of others. Then beyond that it is to maintain the energy of innovators even with these barriers. So I would say political mapping and early communication are important ways that we overcome our valley of death barrier.</p>
Q4	<p>Would you say the organization, as it existed at the time the venture kicked off, or the general recognition of the need for innovation, was well designed for that, or were changes to the organization design required?</p>
R4	<p>It is very difficult to generalize about Shell, so I'll just keep my comments to Shell Chemicals. Shell Chemicals is a part of Shell that is about 10% of the revenue stream. It is essentially by-products to hydrocarbons used in fuel. It is fuel's by-product, so that's the reason I have a petrochemicals operation.</p> <p>Just before the design and implementation, of our GameChanger effort, there had been significant divestitures for Shell Chemicals. We chopped off about 40% of our portfolio—those that we call further downstream, and with those product lines that are not fairly close to the oil well, or the refinery, or the refinery equipment called the cracker that produces ethylene to make polyethylene, which is plastics, and things like that. So the environment was in need of nurturing very much, having gone through that somewhat traumatic divestiture exercise.</p>
Q5:	<p>What were the expected benefits that compelled your company to strive to be more entrepreneurial?</p>
R5:	<p>Well, the expected benefits are just a more productive use of your technical and intellectual property development resources towards the end of Donner and foot hydrome for innovation to produce viable growth opportunities. By the way, will you send me a draft of your interview?</p>
Q6:	<p>Sure. I'll make a note of that. Got it. Next question is does your organization have a reserve of human resources that are available to pursue new opportunities on short notice, should arise?</p>

R6:	To some extent yes.
Jason:	Do you care to elaborate on the nature of those resources?
Shell:	Well, the way that we operate is to fund in a sort of venture capital, or even angel funding manner. The development of innovative ideas is on the part of both technical and business people who have day jobs, so it is a little like the 3M model of a 15% allowance to all of the finest engineers to pursue innovative projects. The GameChanger approach in Shell allows that, but it knows if we have fought the people who can come to GameChangers for example, for a full year's support. No, we will support various stages. We have a stage gate process of an idea to either fruition, or to the waste bin.
Jason	So these people, is it GameChanger is the excess of the reserve resources?
Shell:	<p>No. What our GameChanger budget supports is some management. We have various parts of the program. We have a manager for the pipeline, which is taking ideas and setting up various stage gates to examine those ideas. We have a way to generate ideas, which is through workshops and through various communications, and that budget is managed. We have the process that I look after, which is externalization, which is looking to identify trends and discontinuities, and things that are going on in the external environment, which could be providing either significant opportunity for us, or significant disrepute threat.</p> <p>Then we have new program called Advance Technology, which is managed, and looks in more detail at a portfolio in emerging technologies for example, nano technology or particular ionic INX solvents, or things that are being discussed widely in universities, and at conferences. We would try to examine what the potential is for those to provide some means for commercial ideas into our GameChanger portfolio.</p>
Jason	So the game-changer--kind of like you were talking about the 3M 15% model--is an enabler for the existing people within the organization?
Shell	Yes. It is, but the budget is to support the design and efficient deployment of programs, and then for the nurturing of particular projects.
Q8	So the people that you earlier described as excess or reserve human resources, are they in all types of jobs then?
R8	Yes, we get ideas from all over the place.

Q9	The organization, is it a centralized or decentralized organization?
R9:	It is centralized.
Q9	And these people, when they are doing their innovation, their ideas, do they have a separate reporting structure? Do they come to the GameChanger?
R9:	They come to GameChanger for budget support. We have budgets and we have project numbers, and we have ways in which they can tie into our project numbers.
Q11	These people, or the innovation, are they aimed at achieving process or product improvements, new markets, existing markets, or all of that?
Q11:	All of that.
Jason	So everything is fair game?
Shell:	Yes.
Q17	Has Shell always had this GameChanger or 15% type model?
Shell	<p>No. The GameChanging model really was introduced by our exploration and production sector, E&P as we call it, in the middle 1995, 1996. E&P is about 60 or 70% of the firm's revenue, so it is a fairly big budget that they have. That was in recognition of the fact that in some areas of E&P, even though Shell is regarded as a technology leader, we were beginning to lose some of that leadership position. So, it was seen somewhat defensively, but also, in terms of an offensive, the bases of innovation for growth. So it was in the middle 90s where the GameChanger came to being.</p> <p>We have always had very strong technology innovation going on with different models, you know, go away from a very academic model to a purely applications and market-driven model.</p> <p>I would say that our bent is towards technology. We're really a technology and engineering company, and I think what game-changers does, is it provides a little bit more of a grass-roots approach to linking with higher level strategy, so it allows—its like the internet---just one more way that you can bring ideas to market.</p>
Q13	Why or when did the firm implement the creative capacity, or this excess capacity, you said 1995, 1996, and it was to defend market

	position?
R13:	Well yes, it's a number of different reasons. I think it is just a recognition of its need, defending market position, the recognition within a large company that you would need to put in place a way to more rapidly examine emerging ideas, and provide for a channel in which support can rapidly brought to bear on attractive opportunities.
Q14	When are the creative capacity, or these people being innovative, and you talked about the 15%. Is it 15% as 3M does it?
R14:	It varies. We support some people, and 50% is probably the maximum we would support anybody for. It can be as little as 5%. We might support somebody for less than a month, then a year, just to write a proposal, or to visit equitable trade shows and give us a report on some emerging technology. It does vary.
Jason	You had earlier spoken about the innovative ideas coming throughout the company. Does the allocation of how much time they are allowed to be innovative depend on where they are within the organization, or is it based on the idea?
Shell:	It is essentially based on the idea, and our job as program managers is to promote the availability of this channel.
Q15	How was this GameChanger implemented? Was it incrementally or radically, or how was it done, or is it still being done?
R15	It is still being done; in fact, just next week we will be having a coalition meeting which brings together GameChangers from various sectors within the organization, E&P, we have a gas and power area, we have a fuels area, we have our chemicals area. We will all be meeting together in Houston as it turns out. Normally we meet in Europe, but we are meeting in Houston this time. Part of our discussion will be looking at the vision for what is next, what should we be doing differently, and indeed part of the change that we are continually looking at is the fact that the most important innovations that we see in our industry are across sectors; for example, chemicals linking with fuels, fuels linking with E&P, or all three linking together, to bring together some technical where withal to solve a particular technical problem, and perhaps even create a new market.
Q16	With this innovation that is taking place, it is taking people away from the efficiency, or from the day-to-day operations of the organization, so as a result, were additional people hired or obtained? How was that

	compensated?
R16:	No, we don't hire people in specifically for GameChanger. The energy and the petrochemicals business is a pretty competitive business, so you really are making staff additions on the basis of your assets or sales position. It turns out that the barriers to admitting ideas are workload # 1, so people are still having to do their day jobs, and the other one it turns out, is linkage with strategy. So we spend some time with the various business units in our sector. We have product business units, so we try to make sure that we can link up to what their needs are, so indeed, we don't hire new people for this. As they become familiar with the issues faced by the petrochemical industry, there are groups to innovate, we find it enhanced.
Q17	Have the stakeholders balked at this inefficiency or the perceived inefficiency of this innovative time?
R17:	It is a continuous struggle, especially in a business like petrochemicals, which is a very competitive business. It is one in which all of the major players are involved, its very capital intensive, so just looking after the assets in the ground takes a lot of people's attention, and as a innovated dilemma its hard to introduce some new stuff into a game that is already hard to play, is attention that we continually face, and will continue to face I would say.
Jason	How do you go against that—on a case-by-case basis?
Shell	Well, we just try to articulate our successes. We try to articulate what value we are creating here, and remind the company about that.
Q18	Has the firm ever—this is kind of a redundant question after you talked about not hiring and the workload-- but does the firm ever participate in business process re-engineering, or contracted experts, anything like that?
R18	Yes. Shell has a continuous stream of vulture-like consultants circling all of our buildings every day of the year. We've done every type of re-engineering you can think of.
Jason	Has it been successful?
Shell:	Not always. It's expensive. I guess those people find less business here, but yes, we've done re-engineering, we've done quality, we've done managing objectives, we do the lot. We've got diversity till the cows come home.

Q19	How has the firm determined the optimum amount of this innovative capacity?
R19:	I don't think we have.
Jason	So it's a constant?
Shell:	Yes. You know, it depends on what are your aspirations for growth. This is a large global company and even the proposition of growth is viewed differently at different parts of the world. It is viewed differently in Europe than it is here, and is viewed differently in Asia than viewed here, and is viewed differently between different sectors, and it is viewed differently at different times in the economic cycle. So, I don't think you can, in fact, optimize, you've just got to keep that tension going. As long as you have the recognition that innovation is an important driver for growth, and growth at some level is required in order to give you a decent share of the returns, then we are going to continue to do it, but as far as going optimum, I don't think so.
Q20	What measures are used to determine the amount of innovation that is going to take place?
R20	We are still working on this and if we know how to do that, we would probably keep it secret. You know, in some companies you've got fairly straightforward measures, and it depends on how your business plays. Like the drugs companies can spend 15 to 20% sales because they get a patent position, which allows them to have a virtual monopoly for a good number of years. Or in the case of Intel, they spend about the same time, and have been able to gain about an 80% share in some of the microprocessor markets. The oil and petrochemical business has already gone. You know, we were the initial ones in the antitrust deals, so there is not way that we are going to want to get any monopoly position; there is lots of laws against that. So, that's why I say growth is not so easy to articulate in these types of markets, because of the three international oil majors as BP, Shell, and Exxon, we already work in very harsh competition with each other, but by the same token, in many of our businesses we work quite closely together.
Q21	This may be a silly question, but what has been the primary outcome resulting from the additional innovative capacity?
R21:	The primary outcome, I think, is a continued and growing awareness of the value of developing an innovative entrepreneurial culture. That is based on the fact that we do have some successes that we can point to. I cannot tell you about them because our hand of point, we're essentially in angel funding of energy capital, so we hand stuff off to a business

	<p>unit, who then takes the responsibility to commercialize that. We have been able to do that several times now. I think that's the value that is recognized here in terms of, or in the face of very difficult market conditions, in the face of a fairly interesting demographic we tend to be rather more skewed toward the 40 and 50-year-old demographic, than the 20 and 30 year-old demographic in our industry. We have still been able to maintain some output in terms of new ideas for new revenue streams.</p>
Q22	<p>What were some attempts at this innovative capacity that have failed, and why?</p>
R22:	<p>Well, there is several. We do a lot. The idea of stage-gate is one of the best practices in innovation. The idea is that you have a funnel with a wide-open front end where ideas go in, and it very rapidly narrows down.</p> <p>So, you might take 100 ideas to produce one commercial revenue stream. So we do a lot of things. Remember the reasons will generally be technically it doesn't work. Economically you can't get the margins out of this. It is not a good strategic fit. Somebody else has done this, we've found our patent position that you know you are going against. All of those things are part of the innovation process. It is part of the nurturing innovation process to find out if this great idea that you've got is going help you make any money.</p>
Jason	<p>All right, that concludes the phone portion. I will e-mail you a written portion. It just requires you to put in numbers, and it is typically taking people five minutes. If you could get that back to me by sometime early next week that would be great. There is one portion where the thing was designed where you were to circle a number 1 through 5, on your e-mail or on you word document, just bold your choice, unless you choose to print it out and just mail it to me, whatever is easier for you.</p>
Shell:	<p>I'll e-mail it.</p>
Jason	<p>Do you have any parting thoughts or comments?</p>
Shell:	<p>Well, as I say, I am surprised that you are not familiar with stage-gates, because that is the recognized best practice in innovation, seeing that it appears in several different forms. Basically it's the fact that you have various measures to encourage ideas, to generate ideas, to evaluate ideas; then you have a fairly aggressive stage gate whereby you allow some work to be going on at a small scale. It might just a paper project to begin with. It might be just some calculations to begin with, and it might be just writing a proposal to begin with. Then it gets through a</p>

	<p>second stage gate, which might involve buying some equipment, doing some experimental work, doing some market studies, what have you. Then you get to a third stage gate, which is the final stage gate, which is where we would hand this off to a commercial business for commercialization. In the literature, you will see various forms of that. So that is sort of the backbone of our program here, that we find ways to encourage the generation and submission of ideas, then we subject these ideas to a fairly rigorous stage gate process.</p>
Jason	<p>Thank you so much for your help, and I will be sure to get you a draft of this once it comes together in the next couple of months.</p>
Shell	<p>Will it take a couple of months to do it?</p>
Jason	<p>I don't know. I actually have to gather all this information, get everything put together, then analyze it. Then I will give it to you. Do you want a draft of my final thesis effort? I will get this to you. This is the first crack at this kind of thing in the Department of Defense. It is pretty bread and butter foundation.</p>
Shell	<p>What is the objective of doing this in the DOD?</p>
Jason	<p>The DOD is trying to transform and is trying to do things better with less resources, so we are trying to investigate the use of the entrepreneurial mind-set in the Department of Defense, and the use of giving people time to, above and beyond their daily work, be innovative. So, we are asking industry leaders such as Shell what they are doing to overcome these barriers. So we will see how it comes together.</p>
Shell	<p>O.K. Thank you very much.</p>
Jason	<p>Thank you, and have a good day. Bye.</p>

Appendix L: Xerox Interview Transcript

Interviewer: Captain Jason Whittle

Date: 21 October 2002

Q1:	What caused the company to pursue entrepreneurial ventures or new innovations?
R1:	Xerox itself was created for new innovations. The whole basis for the corporation was an innovative process that left its mark on virtually the world. Process work is different because of what Xerox invented a long time ago. Xerox sees its mission, if you like, as continually reinventing how people work, the kinds of tools people work with. We are definitely an innovation driven company.
Jason	Ok
Xerox	Is that enough or do you want me to go on?
Q2	That's a good start. Question 2, Describe the key challenge that was faced regarding this venture or innovation? Or, in light of you answer to question 1, if there are challenges any time you guys step out to reinvent something.
R2:	Well, I think the world has changed. Lots of other companies have been formed and are in direct competition with Xerox. We are not alone. We have a lot of competitors, very competent competitors. I would say that we are in a technological crunch, always to identify what new technologies you need for the future and be the first to market with theses. I would say time to market; speed to marketplace.
Q3:	Ok, and are there any barriers to overcome that challenge, the time to market?
R3:	Pretty open ended question. There are always limitations. You never have enough money. So I would say sometimes you have a strong core business and you want to keep pumping money in that but at the same time you want to invest in the new thing that will transform your business. Finding that balance is hard because really your making money that will allow you to fund new business. I don't know if it is a barrier or a challenge; finding the right mix between investing in core versus creating new things. We spent over \$1billion in R&D last year and will spend over \$1billion this year. Core businesses demand a lot of R&D. It's a technology driven business.
Q4	Ok. Question 4, Would you say the organization as it existed at the time the venture kicked off was well designed for the venture—or were changes to the organization design required?

R4	That question suggests you are talking about a specific venture. Xerox has formed many companies. In all times companies and subsidiaries and spin-offs have been formed with a specific purpose or objective. I'm not sure I can answer that. Say the question again.
Q4	Would you say the organization as it existed at the time the venture kicked off was well designed for the venture—or were changes to the organization design required?
R4	Well, most of our ventures, our true ventures, have been set up as separate, independent companies. In some ways that implies change because you nurture them outside the core business, outside the core processes. You make them compete with kinds of businesses they will compete with versus the kinds of business we have today. If you are going to start startup companies in silicon valley, you want to set up those firms, the incentives, the structure, then be competitive with Silicon Valley startups. They are going to attract different kinds of people; they are going to have different compensation plans. You want to be relevant to the kinds of business they are in. In some ways, they are very different. For example, if you start up these ventures, you want to motivate employees with a higher component of compensation due to future value of the firm. Option in new companies. Stock options are a component of executive compensation of Xerox. It's not like if I do my job really well I'm going to own 10% of Xerox.
Q5	Ok. Q5, What were the expected benefits that compelled your company to strive to be entrepreneurial?
R5:	Well, I think by forming ventures and spin-offs we hope to move into some areas, faster growth areas. We are looking for getting significant multiples in value if you like. There are certain areas that are hot always in terms of external valuations; they are much higher than traditional companies like Xerox and many of our competition. It's basically to get a higher return. Speed and execution. We expect to be able to move faster, again through ventures. Can I think of anything else? Those are the first two that come to mind.
Jason	If we need more, we can call you back
R5	Oh, there is one more. New ventures, spin-offs, can attract external investment. It helps Xerox, the parent company, balance the risk and return. You obviously give up something when you sell partial ownership, but they also assume some of the risk too. So it's balancing risk and attracting external investment. Leveraging other people's money

Q6	Great. Question 6, Does your organization have a reserve of human resources that are available to pursue new opportunities on short notice, should they arise?
R6:	We demonstrated some agility. There is no formalized structure per se. We have been able to in some cases to rally resources around a new venture but there isn't a formal structure. We do have experts in corporate who are experts in negotiation, finance, legal matters; they are resources that help out. But they don't become dedicated, they are just consultants.
Q7	Ok. So would you say, the next question says, Describe the nature of the reserve resources.
R7	Business development, finance
Jason	So they are experts?
Xerox	Yeah and we have people who specialize in alliances and legal support
Q9 & Q10	Ok. And who do these people report to? Are they centralized, decentralized?
R9 & R10	We have a services department. Not a department. It's quite a hefty group. A business group. Corporate operations group, I think it's called.
Jason	All right. So these, just to reiterate, these specialist or experts are centralized?
Xerox	Yes.
Q1	The next question is concerned at the goals these specialists are aimed at achieving. Is there anything above the obvious? The specialists for finance, or any of these?
R11	They are not dedicated to helping with new ventures. They are there in the overall governance of the business. But they have expertise that is useful in the other areas. Xerox has acquired other companies. We purchased the printing division from Techtronics a few years ago, for example. These internal resources served to help with every aspect, particularly the due diligence when you are spending a billion dollars on an acquisition.
Q12	Ok. This setup with the corporate governance, has it always been in

	place?
R12	No, it is relatively new. No, it hasn't always been in place. The way it is organized now is relatively recent. Some of the groups have been in other areas in the past. They've been around for a couple of years anyways.
Q14	Ok. I'm skipping questions you've already answered. Within the firm, it's probably hard because you are diversified, but do the personnel, the worker bees, do they have time to be innovative?
R14	It means different things to different people. Certainly in research and development community, it's an expected outcome. Xerox has consistently been in the top 10 US companies in getting patents. If you use patents as a measure of innovation output of our company, I'd say we're pretty good at it. But I think innovation can occur in business process, how you approach customers, how you serve the marketplace. It can occur in many different ways, not just the product side. I think it is encouraged. Difficult to measure. That's why I throw in the patents because that's something I can go look up and track for. People associate patent with innovation. It's hard to nail it down.
Jason	Yes sir. When you say it is encouraged, I assume that means ever since Xerox's inception?
Xerox	I would say that doing things differently is something that management encourages. We are not in the business as usual mode. Xerox has had its share of financial difficulties in the past few years, and competitive pressures, so we are constantly challenged to find better ways to do things. Maybe its pressure. It's not always enough to get 5% improvement on stuff. Sometimes you have to think of an entirely new way of doing something. When the gap to where you want to be is so big.
Q17	The stakeholders within Xerox, do they ever balk at the perceived inefficiency? Maybe in the R&D or the excess capacity in the other organizations that's built in. Is there ever a challenge with that?
R17	Not that I'm aware of. I think the stakeholders, represented by the board, look at our operation and I don't see that as a particular area. The last few years we've focused on becoming leaner and meaner, I think we've put a lot of that behind us.
Q19	Does your firm have a way to determine the optimum amount of creative capacity?
R19	We set the overall R&D level at the top of the company. There are a lot of factors that go into that. It's kinda complex. You look at the type of

	business you are in, the cadence you need, how much you chose to do in house versus acquire externally. It's a very complex process. We do set our overall R&D level which does affect our capacity. Not a simple algorithm. Obviously you look at your competitors, you capabilities, and efficiencies. Two organizations could spend the same amount on R&D and get very different output from that.
Q20	Is this a continuing process?
R20	We revisit annually. We set targets. For all the R&D sub organizations, we set targets. We understand their needs. They always ask for more than we want to give them. Obviously we want to get max profit too. We challenge people to do more with less all the time. But obviously you don't want to damage the business either. We do this annually. It's a rigorous process
Jason	Ok. You alluded to profit. Are there other measures to determine the effectiveness?
Xerox	Of R&D?
Jason	Yes
Q20	Absolutely. But profit is a good one. The amount of profit per R&D dollar. Revenue isn't a good one because you can generate a lot of revenue and lose money. So you want to have profitable revenue or profit per R&D dollar. What companies like to look at is how much revenue is coming from new products versus legacy products. It tells you how fast you are innovating; how fast you are turning over the base. It's not something you always want to do. You also want to get the max value from previous investment too. So simply creating new products for the sake of new products is not the right answer. Effective reuse of technology is something you want to take a look at. That can be measured too.
Q21	Ok. The next question is kind of redundant. It says "What has been the primary outcome resulting from the availability of the additional resources?" I imaging you've alluded to that just saying the R&D.
Xerox	Additional resources, you referring to excess support resources in ventures?
Jason	Generally in this field it's talking about excess human resources that I believe Xerox has in R&D. Mainly in the R&D sector. Is that correct?
R21	In business development in general, I think but you know the benefit

	from having that is that you have experts to go to and get quick response rather than going out and hiring a firm, and qualify them, disclose them etc etc.
Q22	What are, were, some attempts at creative capacity that failed? I guess that doesn't fit in light of your other answers.
Xerox	Creative capacity, you mean adding...
Jason	Excess human resources.
R22	Well, not all projects we've started we've completed. We've gone certain ways and decided to stop something. There are lots of examples like that. I don't know if that's a failure. I think making the decision early enough to quite is a success rather than spending a lot of money on it then deciding to quit. I don't think we've ever created capacity that sat around and didn't get used.
Jason	Do you have any paring thoughts?
Xerox	I've worked in private sector and public sector, like utilities. I think you see a common pattern. People get scared of stepping out and doing something different. Organizations typically get good at something and there are endless numbers of originations that have trouble moving on to other things. Utility companies tried to be more than utility companies. They thought, "well, we have certain infrastructure and we can become something else." It never worked. And I think it never worked because they always failed to look at the outside, who they were going to compete with and what it takes to be competitive. They've always had a very introspective view of things. Looked at what they know well and tried to do that somewhere else. It's not always possible. If you are in business and you want to expand, you need to acquire new capability. In fact, I had many interactions with the national labs several years ago when they were under pressure to find civilian applications for technology developed for other purposes than originally developed. And that really didn't yield to the extent people would have liked. Kind of a National labs mentality trying to compete with agile high tech companies. They had good capabilities; their technology was very good. But it takes more than that to succeed. They failed to round up the resources they needed. And they never found them in their organizations. They really have to go outside. Eternal cultures can defeat dramatic departures from the norm.

Appendix M: Numerical Assessment Responses (Part 1)

Firm	A1	A2	A3	A4	A5	A6	A7	A8	A9	A10	A11	A12	A13	A14	A15	A16
3M	4	5	5	5	5	5	5	5	5	2	1	1	1	5	5	5
AT&T	2	4	4	3	3	3	2	4	4	2	2	4	3	2	2	4
Canon	1	2	2	2	2	1	3	3	2	4	3	5	5	1	1	3
Dow	2	1	4	2	2	2	4	3	2	5	1	5	5	2	1	2
DFD	2	4	4	3	4	3	4	5	5	2	1	3	3	4	4	3
GE	5	5	4	2	4	4	4	3	4	2	1	4	1	4	5	5
Intel**	3	5	5	4	5	5	4	4	4	4	2	2	2	4	4	5
Kone	2	4	4	4	2	3	4	4	4	2	2	3	2	3	3	4
Mobil	2	2	2	2	2	1	2	3	2	4	3	2	3	2	2	2
Shell	2	3	5	3	3	2	4	4	3	3	3	3	3	4	4	3
Xerox	4	3	3	3	3	3	4	4	3	2	1	1	3	3	3	4
Aver	2.64	3.45	3.82	3.00	3.18	2.91	3.64	3.82	3.45	2.91	1.82	3.00	2.82	3.09	3.09	3.64
Median	2	4	4	3	3	3	4	4	4	2	2	3	3	3	3	4
SD	1.21	1.37	1.08	1.00	1.17	1.38	0.92	0.75	1.13	1.14	0.87	1.41	1.33	1.22	1.45	1.12
Min	1	1	2	2	2	1	2	3	2	2	1	1	1	1	1	2
Max	5	5	5	5	5	5	5	5	5	5	3	5	5	5	5	5

Appendix N: Numerical Assessment Responses (Part 2)

Firm	A1.1	A1.2	A1.3	A1.4	A1.5	A1.6	A2.1	A2.2	A2.3	A2.4	A2.5	A2.6	A2.7	A2.8	A2.9	A2.10	A2.11
3M	5	5	5	5	1	1	4	3	4	4	2	3	4	5	3	3	4
AT&T	2	3	1	4	4	4	4	4	4	4	3	4	5	5	4	3	4
Canon	3	2	4	2	3	4	5	3	2	5	4	1	2	3	5	4	3
Dow	1	1	1	2	3	5	3	2	3	5	4	3	2	4	1	1	3
DFD	4	5	3	4	2	2	4	4	4	5	3	5	4	4	2	2	3
GE	4	4	3	4	5	3	1	5	5	3	5	5	5	5	2	2	5
Intel**																	
Kone	4	4	3	2	2	2	4	3	4	4	4	2	5	5	2	2	4
Mobil	3	3	3	2	3	2	3	3	3	4	4	2	3	3	2	3	2
Shell	1	3	1	3	5	4	3	1	2	3	2	2	1	2	2	2	2
Xerox	4	4	2	2	1	3	4	4	4	4	5	3	3	4	3	3	4
Aver	3.10	3.40	2.60	3.00	2.90	3.00	3.50	3.20	3.50	4.10	3.60	3.00	3.40	4.00	2.60	2.50	3.40
Median	3.5	3.5	3	2.5	3	3	4	3	4	4	4	3	3.5	4	2	2.5	3.5
SD	1.37	1.26	1.35	1.15	1.45	1.25	1.08	1.14	0.97	0.74	1.07	1.33	1.43	1.05	1.17	0.85	0.97
Min	1	1	1	2	1	1	1	1	2	3	2	1	1	2	1	1	2
Max	5	5	5	5	5	5	5	5	5	5	5	5	5	5	5	4	5

**Firm's strategic leader did not respond to these questions

Appendix O: Numerical Assessment Responses (Part 3)

Firm	A3.1	A3.2	A3.3	A3.4	A3.5	A4.1	A4.2	A4.3	A4.4
3M	3	4	3	4	3	4	4	5	5
AT&T	2	4	3	2	3	3	1	2	4
Canon	2	4	3	1	1	1	4	4	2
Dow	2	2	2	4	3	3	1	2	1
DFD	4	3	1	4	5	4	2	4	3
GE	5	5	5	3	5	5	3	5	5
Intel**									
Kone	2	5	2	3	3	4	3	2	5
Mobil	3	3	1	2	3	3	2	3	2
Shell	2	3	2	3	2	2	1	1	2
Xerox	3	4	2	4	4	4	3	4	4

Aver	2.80	3.70	2.40	3.00	3.20	3.30	2.40	3.20	3.30
Median	2.5	4	2	3	3	3.5	2.5	3.5	3.5
SD	1.03	0.95	1.17	1.05	1.23	1.16	1.17	1.40	1.49
Min	2	2	1	1	1	1	1	1	1
Max	5	5	5	4	5	5	4	5	5

**Firm's strategic leader did not respond to these questions

Appendix P: Numeric Assessment Questionnaire

Please assign a numerical rating to each of the following observations on a scale of 1 to 5 with 1 being “The observation is not at all descriptive of our organization” and 5 being “The observation is very descriptive of our organization.”

Question	Mean	SD
1. Senior managers encourage the ending of existing rules.	2.63	1.20
2. Top management has experience with innovation.	3.0	1.00
3. There is top management sponsorship of innovative pursuits.	4.0	1.00
4. Individual risk-takers are often recognized whether eventually successful or not.	3.0	1.00
5. There is encouragement for calculated risks	3.0	1.00
6. ‘Risk taker’ is considered a positive attribute.	3.0	1.00
7. Small and experimental projects are supported.	4.0	1.00
8. People get second chances after mistakes.	4.0	1.00
9. Mistakes are seen as learning experiences.	3.0	1.00
10. It is important to look busy in our organization.	2.9	1.10
11. It is difficult to form teams in our organization.	1.8	.9
12. There is a concern for job descriptions.	3.0	1.4
13. Defining turf is important.	2.8	1.3
14. Funds are readily available for the pursuit of innovative ideas.	3.1	1.2
15. The organization’s budgeting process facilitates funding innovative ideas.	3.1	1.4
16. There are additional rewards/compensation for successful innovation.	3.6	1.1

For this section the scale extremes are presented in the description on opposite sides of the scale. Note that there are no right or wrong answers to the questions below, and that each question is independent of the others. Please indicate by circling the appropriate number the extent to which the following statements reflect your opinion:

	1 strongly disagree 5 strongly agree		Mean	SD
1.1) There is wide variation in opinion about what innovation ideas will be acceptable to our company	1 2 3 4 5	Most people understand exactly what innovation ideas are considered desirable by this company	3.1	1.37
1.2) It isn't clear why many innovation ideas are approved	1 2 3 4 5	It is always crystal clear why innovation ideas are approved	3.4	1.26
1.3) Our formal reward systems are focused mostly on excellence in running our existing lines of business	1 2 3 4 5	Our formal reward systems are focused mostly on new business development	2.6	1.35
1.4) The goals for new innovation projects are generally very ambitious, home-run type plays	1 2 3 4 5	The goals for new innovation projects are generally not too ambitious, more "doubles and triples" plays	3.0	1.15
1.5) Our firm does not have a problem with making significant investment in a business before it shows returns	1 2 3 4 5	Senior managers in our firm resist making significant investment in new business prior to the commencement of a revenue stream	2.9	1.45
1.6) The approach when it comes to funding is to invest as many funds as are needed ahead of time to get the project	1 2 3 4 5	The approach when it comes to funding is to try to postpone investments and expenditures for as long as possible	3.0	1.25

started				
---------	--	--	--	--

For this section please note your agreement from 1 (strongly disagree) to 5 (strongly agree). Note that there are no right or wrong answers to the questions below, and that each question is independent of the others. Please indicate the extent to which you agree or disagree with the following statements:

	1 strongly disagree 5 strongly agree	Mean	SD
2.1) People are not rigidly held to plan but are encouraged to adapt to unfolding circumstances	1 2 3 4 5	3.5	1.08
2.2) We can rely on timely intervention from senior management when it is required to move a project forward	1 2 3 4 5	3.2	1.14
2.3) We are able to identify ahead of time ways to make effective use of our reputation as a lever in our negotiations with stakeholders	1 2 3 4 5	3.5	.97
2.4) In gathering support for innovative ventures internally, we tend to focus on creation of commitment from needed supporters rather than pursuing rational arguments to justify the project	1 2 3 4 5	4.1	.74
2.5) We are able to identify those places where inertia or disinterest are likely to impede progress	1 2 3 4 5	3.6	1.07
2.6) Our approach to opposition which refuses to be persuaded is to confront them directly	1 2 3 4 5	3.0	1.33
2.7) We are able to proactively take actions to cope with growth	1 2 3 4 5	3.4	1.43
2.8) We are increasingly improving our efficiency	1 2 3 4 5	4.0	1.05

2.9) Our attention is focused primarily on external rather than internal issues	1	2	3	4	5	2.6	1.17
2.10) Our communications are primarily with outsiders rather than internal	1	2	3	4	5	2.5	.85
2.11) We have plans to and are able to train our customers, suppliers, and /or the branches in order to help them cope with our rapid growth	1	2	3	4	5	3.4	.96
	1 strongly disagree 5 strongly agree					Mean	SD
3.1) We have reserves set aside to allow us to cope with budget and staffing needs	1	2	3	4	5	2.8	1.04
3.2) People working on new ventures make decisions on the basis of a few core values rather than a large number of rules	1	2	3	4	5	3.7	.95
3.3) Our human resource function is focused on developing new talent rather than administering existing personnel	1	2	3	4	5	2.4	1.17
3.4) New people that come on board are easily assimilated and feel that they can cope very early on	1	2	3	4	5	3.0	1.05
3.5) We are able to anticipate and staff up with sufficient new people to support the evolution of a new project or venture	1	2	3	4	5	3.2	1.23

	1 strongly disagree 5 strongly agree	Mean	SD
4.1) There is a firm policy to frequently revisit the basic assumptions of the business and question their future validity	1 2 3 4 5	3.3	1.16
4.2) We assume that a significant percentage of our existing business will become obsolete each year	1 2 3 4 5	2.4	1.17
4.3) New business development occupies a high position in the agenda of the managers	1 2 3 4 5	3.2	1.4
4.4) Our mindset is one of creative discontent with the status quo	1 2 3 4 5	3.3	1.49

Appendix Q: Notes Developed During the Pattern Matching Process

Response 1

(What caused the company to pursue entrepreneurial ventures or new innovations?)

Themes that Came Up More than Once:

- Demand for service/or goods being created (Canon & Mobil)
- Firm is capable of being entrepreneurial (DFD & Canon)
- Firm is capable of managing risk (DFD & GE)
- Firm is focused on innovation (Canon & Xerox)
- Wanted to improve/reinvent processes (AT&T, 3M, & Xerox)
- Nature of business (Canon, Intel, & Xerox)
- Firm history of entrepreneurship (Dow, Intel, & Kone)
- Desire to increase profitability/make money (DFD & Dow)
- Needed to change business practices to reach “growth fantasy” (Dow & Shell)

Themes that Only One Firm Mentioned:

- Staying competitive (Shell)
- Large firm trying to work simply (AT&T)
- Innovation is one of firm’s “added values” (Intel)
- Entering new product markets (Shell)
- Balancing out (GE)
- Company Structure (Kone)
- Changing (more global) environment (Kone)
- Gain customer loyalty (Mobil)
- Address issues of customer “speed” and “convenience” (Mobil)
- Board of Directors (NCR)
- Bring out best practices in house (NCR)

Response 2

(Describe the key challenge that was faced regarding this venture or innovation)

Themes that Came Up More than Once:

- Selectivity and/or being able to identify worthy concepts (AT&T, DFD, Canon, Shell, & Xerox)
- Execution (Mobil & Shell)
- Buy in within the firm (Mobil & NCR)
- Maintaining the spirit/initiative the entrepreneurship created (Kone & NCR)
- Giving project time and resources to succeed (DFD & Dow)
- Funding (3M, AT&T, Intel, Mobil)

Themes that Only One Firm Mentioned:

- Communication between US subsidiary and Japanese parent company (Canon)
- Maintaining credibility (DFD)

- Monitoring the number of small entrepreneurial projects going on simultaneously (AT&T)
- Lack of funding (3M)
- Controlling costs (AT&T)
- Thinking about the whole life span of the process (DFD)
- Competition (i.e. firm has very competent competition) (Xerox)
- Speed to marketplace (Xerox)
- Small group develops the concept but a different group implements/executes so the first group has to convince the second that this is a worthwhile idea (Mobil)
- There is no “generic” answer to this question (Dow)
- “Innovation is a full-time job.” Can’t use part-timers to innovate (Dow)
- “Innovator’s dilemma” (Shell)

Response 3

(Describe the barriers that had to be overcome to accomplish the challenge)

Themes that Came Up More than Once:

- Competition for resources—often between small entrepreneurial projects and big projects that entail a more familiar concept (AT&T, DFD, NCR, Xerox & Dow)
- Finding time to make it work (DFD & NCR)
- Buy in (AT&T, DFD, Mobil, Shell, Dow, & Intel)
- Risk (DFD, GE, & Dow)
- Defining the new process/product (AT&T, Shell, & Intel)
- Cultural differences (Canon, Kone)
- Communication (Intel, DFD, Mobil & Shell)

Themes that Only One Firm Mentioned:

- Creating a new faster moving process (AT&T)
- Company culture (AT&T)
- “have to generate more revenue” (Dow)
- “innovation and efficiency tend not to go into the same sentence” (Dow)
- Language barrier (Canon)
- Distribution (Intel)
- Make or convince others to make the equipment that you need if it does not already exist (Intel)
- Communication (Shell)
- “thought barriers” (Shell)
- Being able to assess the political landscape (Shell)
- Finding out “what customers need” (3M)
- Developing products to meet customers’ needs (3M)
- Change in focus to take into account feedback from subsidiaries (Canon)
- Accurately pricing a product (GE)
- Accepting the leadership role (Kone)
- Balancing time versus money (Intel)

- Giving potential entrepreneurs/innovators a nurturing environment where they are unafraid to come forward with even their unfinished ideas (Shell)
- Need to create a product people want to buy (Intel)
- Communicate new capability to potential customers (Intel)
- Amount of R&D required for core businesses (Xerox)
- Technology driven business/must solve technical problems (Xerox & Intel)
- “discovery is a fickle thing” (Intel)
- Having the right people in the right place at the right time (DFD)
- More work required to qualify something new (DFD)
- Trying to solve problems that have “no known solution” (Intel)
- Betting on your own “skill/intuitive innovation” (Intel)
- Maintaining the “energy of innovators” despite barriers (Shell)
- Potential for bankruptcy for failure (DFD)
- Difference in ideology between entrepreneur(s) and the strategic plan of firm (DFD)

Response 4

(Would you say the organization as it existed at the time the venture kicked off was well designed for the venture—or were changes to the organization design required?)

Themes that Came Up More than Once:

- Firm has changed a great deal (AT&T, Canon, Intel, Dow, Shell, & Kone)
- Changes were needed for better communication within the firm (Canon, DFD)
- Had separate venture fund (AT&T, Xerox)

Themes that Only One Firm Mentioned:

- “All of these are works in progress”...“constant state of flux” (Dow)
- Varies depending on which part of the firm is being referenced (Shell)
- Different levels entrepreneurial plan must go through (DFD)
- “Company was predominately formed by scientists and engineers: (Intel)
- “The probability that you are going to correctly anticipate all of this at the beginning is zero” (Dow)
- Started as Fairchild Semiconductor and then branched off as a start-up, many of the original workers transferred to the new firm (Intel)
- Recently made many changes in Shell Chemicals department, needed a lot of nurturing after a “somewhat traumatic divestiture exercise” (Shell)
- Started out as a mining company and “turned into an R&D company” (3M)
- Similar to research lab setup, with equitable teams but one person who ultimately makes the final decision (Intel)
- “Everybody on the team has expertise and knowledge that they are expected to bring to the problem, and everybody operates predominately more at an equal level” (Intel)
- Needed to set up training (DFD)
- Changes were more bottom level (Mobil)
- Needed to realign roles/responsibilities to match new initiatives (NCR)

Response 5

(What were the expected benefits that compelled your company to strive to be more entrepreneurial?)

Themes that Came Up More than Once:

- Profitability/increased value (AT&T, Canon, GE, Kone, 3M, Intel & Xerox)
- Balance risk (DFD, Xerox)
- Customer satisfaction (Canon, Mobil, & Intel)
- Growth (GE, Xerox, Shell, 3M)

Themes that Only One Firm Mentioned:

- “Biggest motivation is survival” since the firm is relatively new (Intel)
- That a useful new and different technology be developed (AT&T)
- Coming up with new products or better products than what was currently available (Intel)
- “more productive use of ...technical and intellectual property development resources” (Shell)
- sales (3M)
- Lifetime employment in Japan (Canon)
- Differentiate firm to customers (Mobil)
- Employee loyalty (Canon)
- Producing quality products (Canon)
- Want to recognize discoveries with great promise, be able to bring those capabilities to the market place and successfully market those to allow your firm to grow from small successful startup to “continually growing successful large business” (Intel)
- More cohesive business unit (Kone)
- Better understand who firm’s customers really were and their spending patterns (Mobil)
- Reward good customers and entice them back (Mobil)
- Firm expects to move faster through the execution of new ventures/spin-offs which result in more external investment (Xerox)

Appendix R: Additional Questions Asked During Telephone Interviews

Entrepreneurial Mindset/Creative Capacity Questionnaire

Name of Company:

Name of Participant:

Phone:

Email:

Position/Job Title of Your Supervisor:

Q6 Does your organization have a reserve of human resources that are available to pursue new opportunities on short notice should they arise? (If necessary explain that we are particularly interested in the capability over and above the resources necessary to meet everyday work requirements).

Q7 Describe the nature of the reserve resources

Q8 What type of jobs are the people in?

Q9 Who do they report to? (centralized/decentralized)

Q10 Is it a separate group, or is the extra capacity imbedded throughout the organization in all work groups?

Q11 Can you provide examples of the types of goals these resources are aimed at achieving? (process/product improvements, specific markets, anything)

Q12 Has the firm always had an extra capacity?

Q13 When/Why did the firm implement creative capacity? (crisis, need to diversify)

Q14 When is the creative capacity being innovative? (1 hr/day, always, anytime, 15% of the time)

Q15 How was creative capacity implemented? (Incrementally, radically, long period of time, short period of time)

Q16 Were additional resources hired/obtained, or were efficiencies gained from existing resources to provide the reserve?

Q17 Did stakeholders balk at perceived inefficiency? (Of having more capability than day to day operations required)

Q18 How did the firm create creative capacity? Where did the excess capacity come from? (BPR, additional hires, contracted experts)

Q19 How did or does the firm determine the optimum amount of creative capacity?

Q20 How often does it change? What are the measures used to determine effectiveness?

Q21 What has been the primary outcome resulting from the availability of the additional resources?

Q22 What are/were some attempts at creative capacity that failed? Why?

Note: The numbering on the original qualitative and quantitative survey instruments conflicted with one another. This was corrected as much of possible in my thesis proper. In the transcripts the open-ended interview questions are listed as Q1-Q5 rather than Q21-Q25 as they are within the thesis itself. This renumbering was so that the quantitative survey questions would not be confused in the analysis with their similarly numbered qualitative survey questions. The questions themselves were not altered in the analysis only their numbering was changed when necessary.

Appendix S: Notes Regarding the Joint Nature of Data Collection

While analysis of the data collected in this thesis effort focused on characteristics of the entrepreneurial mindset in private sector firms, the data was also used to address issues of creative capacity (i.e. slack in human resources) and how those issues may effect the implementation of the entrepreneurial mindset. Myself and Captain Jason Whittle combined our research effort by creating a joint survey instrument that addressed each of our concerns as they related to implementing the entrepreneurial mindset in organizations. We used this collaborative survey instrument and each of us interviewed a strategic leader from the twelve firms. Capt. Whittle interviewed 7 of the strategic leaders and I interviewed the remaining 5 leaders.

Based on these dual purpose telephone interviews the typed transcripts were created. Throughout the bulk of my thesis research I address only the data collected that pertains to my research questions. At times the strategic leaders would give a response to one of Capt. Whittle's questions that actually related to my research. In those instances data which related to my research focus was gleaned from the responses that related to Capt. Whittle's research focus.

Bibliography

- 3M. Interview with strategic leader, 21 November 2002, interviewed by Capt. Jason Whittle.
- 3M Worldwide. "History: Foundations for the Future." Excerpts from timeline. n. pag. <http://www.3m.com/about3M/history/2000.jhtml>. 24 January 2003.
- Adams, Robert. "Intrapreneurship Right for the Industry," in *Electronic Engineering Times*, 6/12/91995, Issue 852, 31.
- Aldrich, Howard E. "Entrepreneurial Strategies in New Organizational Populations," in *Entrepreneurship: The Social View*. Ed. Richard Swedberg. Oxford University Press (2000).
- Aldrich, Howard E. and Martha Argelia Martinez. "Many Are Called, but Few are Chosen: An Evolutionary Perspective for the Study of Entrepreneurship," in *Entrepreneurship Theory and Practice*, 25: 41 (Summer 2001).
- AT & T. Interview with strategic leader 6 November 2002, interviewed by 2Lt. Rochelle Smith.
- Arrow, Kenneth J. "Innovation in Large and Small Firms," in *Entrepreneurship: The Social Science View*, Ed. Richard Swedberg. Oxford University Press, 2000.
- Baden-Fuller, Charles. "Strategic Innovation, Corporate Entrepreneurship and Matching Outside-in to Inside-out Approaches to Strategy Research," *British Journal of Management*, 6:S3-S16 (December 1995).
- Borins, Sanford. "Loose Cannons and Rule Breakers, or Enterprising Leaders? Some Evidence about Innovative Public Managers," *Public Administration Review*, 60: 498 (November 2000).
- Canon. Interview with a strategic leader, 22 October 2002, interviewed by Capt. Jason Whittle.
- Canon. "History of Canon." Excerpts from timeline. n. pag. <http://canon.com/about/history/index.html>. 24 January 2003.
- Chandler, Gaylen N.; Douglas W. Lyon. "Issues of Research Design and Construct Management in Entrepreneurship Research: Past Decade." *Entrepreneurship: Theory and Practice*, 25:101 (Summer 2001).
- Chelf, Kurt A. *Beyond A-76: How to Achieve the Goals Without the Pain*. MS thesis, AFIT/GAQ/ENV/02M-02. Air Force Institute of Technology (AU), Wright-Patterson AFB OH (March 2002).

- Christensen, Clayton M. *The Innovator's Dilemma*. Harper Business (2000).
- "Community Capitalism: Building Corporate Alliances for Community Development," *Economic Development Review*, 17:17 (Summer 2000)
- Conceicao, Pedro; Dennis Hamil and Pedro Pinheiro. "Innovative Science and Technology Commercialization Strategies at 3M: A Case Study," *Journal of Engineering and Technology Management*, 19: 25-38 (2002).
- Cooper, Arnold C. and Louis A. Weil. "Entrepreneurship: The Past, the Present, the Future." White Paper, 7/22/02. colemanchairs.org/whitepaper.asp.
- Covin, Jeffrey G. and Dennis P. Slevin. "The Influence of Organization Structure on the Utility of an Entrepreneurial Top Management Style," *Journal of Management Studies*, 25:3 (May 1988).
- Covin, Jeffrey G. and Dennis P. Slevin. "Strategic Management of Small Firms in Hostile and Benign Environments," *Strategic Management Journal*, 10:75-37 (1989).
- Covin, Jeffrey G. and Dennis P. Slevin. "A Conceptual Model of Entrepreneurship as Firm Behavior," *Entrepreneurship: Theory and Practice*, 16:7 (Fall 1991).
- Covin, Jeffrey G. and Morgan P. Miles. "Corporate Entrepreneurship and the Pursuit of Competitive Advantage," *Entrepreneurship Theory and Practice*, 23: 47-63 (Spring 1999).
- Cringley, Robert X. *Accidental Empires*. Harper Business, 1996.
- Criswell, John W. *Research Design*. Sage (1994).
- Damanpour, Fariborz. "The Adoption of Technological, Administrative, and Ancillary Innovations: Impact of Organizational Factors," *Journal of Management*, 13:675-688 (1987).
- Damanpour, Fariborz. "Organizational Complexity and Innovation: Developing and Testing Multiple Contingency Models," in *Management Science*, 42:693 (May 1996).
- David, Jaffee. *Organization Theory: Tension and Change*. McGraw Hill, 2001.
- Davidsson, Per; Murray B. Low and Mike Wright. "Low and MacMillan Years On: Achievements and Future Directions for Entrepreneurship Research," in *Entrepreneurship Theory and Practice*, 25: 5 (Summer 2001).

- Dertouzos, Michael. "Four Pillars of Innovation," *Technology Review*, 102 (November/December 1999).
- Dess, Gregory D. "Linking Corporate Entrepreneurship to Strategy, Structure, and Process: Suggested Research Directions," *Entrepreneurship: Theory and Practice*, 23:85 (Spring 1999).
- Dooley, David. *Social Research Methods* (4th Edition). New Jersey: Prentice-Hall, Inc., 2001.
- Dow. Interview with strategic leader, 22 November 2002, interviewed by Capt. Jason Whittle.
- Dow. "This is Dow." March 2003. www.dow.com.
- Drayer, Dennis. "Performance-Based Business Environment," *Program Manager*, 27:57 (January/February 1998).
- Duke/Fluor Daniel. Interview with a strategic leader, 8 November 2002, interviewed by 2Lt. Rochelle Smith.
- Duke Energy. "About Duke Energy." March 2003.
www.duke-energy.com/decorp/content/AboutUs/deip9.asp?RBU=1.
- Edwards, Owen. "That Giant Sucking Sound," *Forbes*, 165:156 (February 21, 2000).
- Ellram, Lisa M. "The Use of Case Study Method in Logistics Research," *Journal of Business Logistics*, 17:93-138 (1996).
- Enbar, Nadav. "Where Big Shots Learn to Think Like Hotshots." *Business Week*, 10/18/99, Issue 3651, 85.
- Fiore, Robert A. and Robert N. Lussier. "A Classification Systems for Entrepreneurship." White Paper, 7/22/02. colemanchairs.org/whitepaper.asp
- Fluor Corporation. "About Fluor Corporation." March 2003. www.fluor.com
- Fortune Magazine Online*. "Fortune 500 Rankings." March 2003. www.fortune.com
- Garamone, Jim. "Bush Touts Military Innovation, Entrepreneurship," *Government Executive Magazine*, 29 May 2001.
- General Electric Company. "Company Information." March 2003. www.ge.com
- GE Capital. Interview with a strategic leader, 25 October 2002, interviewed by 2Lt. Rochelle Smith.

- Goetz, Stephan J.; Freshwater, David. "State-Level Determinants of Entrepreneurship and a Preliminary Measure of Entrepreneurial Climate," *Economic Development Quarterly*, 15: 58, (February 2001).
- Gompers, Paul A. and Josh Lerner. *The Money of Invention*. Harvard Business School Press, 2001.
- Hafemeister, Rod. "Where Bright Ideas Go Demo," in *Air Force Times*, 12/9/02, 12-13.
- Hamel, Gary. "Bringing Silicon Valley Inside," in *Harvard Business Review*, 71-84 (September-October 1999).
- Hammer, Michael; James Champy. "Reengineering the Corporation: A manifesto for business revolution." *Harper Business*, 2001
- Higdon Jr., Leo I. "Leading Innovation," *Executive Excellence*, 17 (August 2000).
- Hitt M.A. and B Bartkus in J.A. Katz and R.H. Brockhaus, Sr. (Eds) *Advances in Entrepreneurship, Firm Emergence and Growth*, Greenwich, CT: JAI Press, (1997), 7-30.
- Hitt, Michael. "Corporate Entrepreneurship and Cross-Functional Fertilization: Activation, Process and Disintegration of a New Product Design Team," *Entrepreneurship: Theory and Practice*, 23: 145 (Spring 1999).
- Hitt, Michael A. and Timothy S. Reed. "Entrepreneurship in the New Competitive Landscape," in *Entrepreneurship as Strategy*. Ed. D. Meyer and K. Heppard. Sage: Thousand Oaks, 2000, 23-47.
- Hochheiser, Sheldon. "AT&T History: The New AT&T." Excerpt from unpublished article. n. pag. <http://192.20.5.56/history/>. 24 January 2003.
- Hopkins, Shirley A; Willie E. Hopkins and Billy Thornton. "Transforming Low-Tech Environments Into High-Tech Environments: Strategies and Developmental Barriers," *SAM Advanced Management Journal*, 14-21 (Winter 2002).
- Hoovers Online*. "The Business Information Authority." March 2003. www.hoovers.com
- Intel. Interview with a strategic leader, 22 October 2002, interviewed by Capt. Jason Whittle.
- Jenson, Jason L. and Robert Rodgers. "Cumulating the Intellectual Gold of Case Study

- Research,” in *Public Administration Review*, 61:235-246 (March/April 2001).
- Kassicieh, Suleiman K. and Radosevich, Raymond. “A Comparative Study of Entrepreneurship Incidence among Inventors in National Laboratories,” *Entrepreneurship: Theory and Practice*, 20: 33, (Spring 1996).
- Katz, Jerome A. Volume Introduction, in *Advances in Entrepreneurship, Firm Emergence and Growth*. Ed. Jerome A. Katz and Robert H. Brockhaus, Sr. Vol.1. JAI Press Inc.: Greenwich, Connecticut, 1993, 7-10.
- Kobrak, Peter. “The Social Responsibilities of a Public Entrepreneur,” *Administration and Society*, 28: 205, (August 1996).
- Kone. Interview with a strategic leader, 25 October 2002, interviewed by 2Lt. Rochelle Smith.
- Kone Inc. “Kone in the USA.” March 2003. www.kone.com/en_US/main.
- Kouriloff, Michail. “Exploring Perceptions of A Priori Barriers to Entrepreneurship: A Multidisciplinary Approach.” *Entrepreneurship: Theory and Practice*, 25: 59 (Winter 2000).
- Kreiser, Patrick M.; Louis D. Marino and K. Mark Weaver. “Assessing the Psychometric Properties of the Entrepreneurial Orientation Scale: A Multi-Country Analysis,” *Entrepreneurship: Theory and Practice*, 26:71 (Summer 2002).
- Kuratko, Donald F., Ray V. Montagno and Jeffrey S. Hornsby. “Developing an Intrapreneurial Assessment Instrument for an Effective Corporate Entrepreneurial Environment,” *Strategic Management Journal*, 11:49-58 (1990).
- Kuratko, Donald F., Jeffrey S. Hornsby, Douglas W. Naffziger and Ray V. Montagno. “Implement Entrepreneurial Thinking in Established Organizations,” *SAM Advanced Management Journal*, 58:28-39 (1993).
- Kuratko, Donald F. and Jeffrey S. Hornsby. “Developing an Entrepreneurial Perspective in Contemporary Organizations,” www.sbaer.uca.edu/Research/1996/USASBE/96usa147.txt (1996).
- Kuratko, Donald F.; Duane R. Ireland and Jeffrey S. Hornsby. “Improving Firm Performance Through Entrepreneurial Actions: Acordia’s Corporate Entrepreneurship Strategy,” *Academy of Management Executive*, vol.15 (November 2001).
- Lee, Sang M. and Suzanne J. Peterson. “Culture, Entrepreneurial Orientation, and Global Competitiveness,” *Journal of World Business*, 35:401 (Winter 2000).

- Luchsinger, Vince and D. Ray Bagby. "Entrepreneurship and Intrapreneurship: Behaviors, Comparisons, and Contrasts." *S.A.M. Advanced Management Journal*, 52:10 (Summer 1987).
- Lumpkin, G.T. and Gregory G. Dess. "Clarifying the Entrepreneurial Orientation Construct and Linking it to Performance," *Academy of Management Review*, 21:135 (January 1996).
- Lumpkin, G.T., Gerald E. Hills, and Rodney C. Shrader. "Opportunity Recognition," *White Paper Commissioned by the Coleman Council for Entrepreneurship Education*, Summer 2002. www.colemanchairs.org.
- Lyon, Douglas W.; G.T. Lumpkin and Gregory G. Dess. "Enhancing Entrepreneurial Orientation Research: Operationalizing and Measuring a Key Strategic Decision Making Process," *Journal of Management*, 26 (2000).
- Markman, Gideon. Survey Instrument. Personal Correspondence. 22 April 2002.
- McGrath, Rita Gunther and Ian MacMillan. *The Entrepreneurial Mindset*. Harvard Business School Press, 2000.
- McGrath, Rita Gunther. Survey Instrument. Personal Correspondence. 31 July 2002.
- Mobil. Interview with a strategic leader, 7 November 2002, interviewed by 2Lt. Rochelle Smith.
- Mobil. "Our Company." March 2003. www.mobil.com/USA-English/gFM/home_contact_US/homepage.asp.
- Morris, Michael H. and Foard F. Jones. "Entrepreneurship in Established Organizations: The Case of the Public Sector," *Entrepreneurship Theory and Practice*, 24: 71 (Fall 1999).
- NCR. "About NCR." March 2003. ncr.com/index3.htm.
- NCR. Interview with a strategic leader, 21 November 2002, interviewed by Capt. Jason Whittle.
- Pramodita, Sharma and James J. Chrisman. "Toward a Reconciliation of the Definitional Issues of Corporate Entrepreneurship," *Entrepreneurship: Theory and Practice*, 23:11-27, (Spring 1999).
- Pryor, Austin K. and Michael E. Shays. "Growing the Business With Intrapreneurs," *Business Quarterly*, 57:42 (Spring 1993).

- Reed, Tim S., Rochelle Smith and Daniel T. Holt. "Making Government More Entrepreneurial: Is It Possible?" Paper for the Academy of Management, Seattle WA, 2003.
- Reilly, Bernard J., and Joseph A. DiAngelo, Jr. "Entrepreneurial Behavior in Large Organizations," *SAM Advanced Management Journal*, 24-31, (1984).
- Reilly, Bernard J. and Joseph A. DiAngelo, Jr. "Traditional Decision-Making Questioned: It's Time for New Thinking for a New Age," *Business Forum*, 18:25 (Winter/Spring 1993).
- Rogers, Everett M. *Diffusion of Innovations* (4th Edition). New York: The Free Press, 1995.
- Rumsfield, Donald. "Transforming the Military," *Foreign Affairs*, May/June 20-32. (2002)
- Shane, Scott. "The Promise of Entrepreneurship as a Field of Research," *Academy of Management Review*, 25: 210 (January 2000).
- Sharma, Pramodita and James J. Chrisman. "Toward a Reconciliation of the Definitional Issues in the Field of Corporate Entrepreneurship," *Entrepreneurship Theory and Practice*, 23:11-27 (Spring 1999).
- Shell. Interview with a strategic leader, 5 December, 2002, interviewed by Capt. Jason Whittle.
- Shell. "About Shell." March 2003. www.shell.com.
- Slevin, Dennis P. and Jeffrey G. Covin. "Juggling Entrepreneurial Style and Organizational Structure--How to Get Your Act Together," *Sloan Management Review*, 31: 43 (Winter 1990).
- Stearns, Tim M. "Turning Ideas into Viable Businesses Takes Action, Not Wishful Thinking," *Business Journal Serving Fresno & the Central San Joaquin Valley*, 19 July 1999, p 6.
- Stevenson, Howard. "Why Entrepreneurship Has Won!" *White Paper Commissioned by the Coleman Council for Entrepreneurship Education*, Summer 2002. www.colemanchairs.org.
- Tuggle, Chris. "Encouraging Entrepreneurial Endeavors in Established Enterprise," Texas A&M University, Department of Management, Summer 2002.

- Vesper, Karl H. "Unfinished Business (Entrepreneurship) of the 20th Century," White Paper Commissioned by the Coleman Council for Entrepreneurship Education, Summer 2002. www.colemanchairs.org.
- Weinstock, Matthew. "Building Entrepreneurs," *Government Executive*, 34: 55 (June 2002).
- Xerox. "Company Information." March 2003. www.xerox.com.
- Xerox. Interview with strategic leader, 21 October 2002, interviewed by Capt. Jason Whittle.
- Yin, Robert K. *Case Study Research: Design and Methods* (2nd Edition). Sage Publications, 1994.
- Young, Jeffrey. "R and Deal." *Forbes*, 3/11/96, Volume 157, Issue 5, 160.
- Zahra, Shaker A. "A Conceptual Model of Entrepreneurship as Firm Behavior: A Critique and Extension," *Entrepreneurship: Theory & Practice*, 17: 5 (Summer 1993).
- Zahra, Shaker A. and John A. Pearce II. "Corporate Entrepreneurship in Smaller Firms: The Role of Environment, Strategy, and Organization," *Entrepreneurship, Innovation, and Change*, 3: 31-44 (1994).
- Zahra, Shaker A. and Jeffrey G. Covin. "Contextual Influences on the Corporate Entrepreneurship-Performance Relationship," in *Journal of Business Venturing*, 10:43 (January 1995).
- Zahra, Shaker A., Jeffrey G. Covin and Patricia H. Zahra. "Organizational Structure, Corporate Entrepreneurship and Performance," *Journal of Enterprising Culture*, 6:111-146 (March 1998).
- Zahra, Shaker A.; Daniel F. Jennings and Donald F. Kuratko. "Corporate Entrepreneurship in a Global Economy," in *Entrepreneurship Theory and Practice*, 24:5 (Fall 1999).
- Zahra, Shaker A.; Donald O. Neubaum and Morten Huse. "Entrepreneurship in Medium-Size Companies: Exploring the Efforts of Ownership and Governance Systems," *Journal of Management*, 26:947-976 (2000).

Vita

Second lieutenant Rochelle D. Smith was born in Seattle, Washington. After graduating from Woodrow Wilson High School in Tacoma, Washington in 1997, she attended Scripps College in Claremont, California. In 2001, she received both her Bachelor's degree in Environmental Science and her commission in the United States Air Force. Upon commissioning, 2Lt Smith was selected to attend the School of Engineering and Management at the Air Force Institute of Technology, Wright-Patterson AFB, Ohio, in August of 2001.

REPORT DOCUMENTATION PAGE				<i>Form Approved OMB No. 074-0188</i>	
<p>The public reporting burden for this collection of information is estimated to average 1 hour per response, including the time for reviewing instructions, searching existing data sources, gathering and maintaining the data needed, and completing and reviewing the collection of information. Send comments regarding this burden estimate or any other aspect of the collection of information, including suggestions for reducing this burden to Department of Defense, Washington Headquarters Services, Directorate for Information Operations and Reports (0704-0188), 1215 Jefferson Davis Highway, Suite 1204, Arlington, VA 22202-4302. Respondents should be aware that notwithstanding any other provision of law, no person shall be subject to a penalty for failing to comply with a collection of information if it does not display a currently valid OMB control number.</p> <p>PLEASE DO NOT RETURN YOUR FORM TO THE ABOVE ADDRESS.</p>					
1. REPORT DATE (DD-MM-YYYY) 25-03-2003		2. REPORT TYPE Master's Thesis		3. DATES COVERED (From – To) Aug 2001 – Mar 2003	
4. TITLE AND SUBTITLE INSTILLING AN ENTREPRENEURIAL MINDSET IN DEPARTMENT OF DEFENSE (DoD) ORGANIZATIONS: EVIDENCE FROM ENTREPRENEURIAL ORGANIZATIONS IN THE PRIVATE SECTOR				5a. CONTRACT NUMBER	
				5b. GRANT NUMBER	
				5c. PROGRAM ELEMENT NUMBER	
6. AUTHOR(S) Smith, Rochelle D., Second Lieutenant, USAF				5d. PROJECT NUMBER	
				5e. TASK NUMBER	
				5f. WORK UNIT NUMBER	
7. PERFORMING ORGANIZATION NAMES(S) AND ADDRESS(S) Air Force Institute of Technology Graduate School of Engineering and Management (AFIT/EN) 2950 Hobson Way, Building 640 WPAFB OH 45433-7765				8. PERFORMING ORGANIZATION REPORT NUMBER AFIT/GAQ/ENV/03-07	
9. SPONSORING/MONITORING AGENCY NAME(S) AND ADDRESS(ES) OSD/FTD Attn: Captain Linda M. Lewandowski 1000 Defense Pentagon Room 3D 980 Washington DC 20301-1000 Phone: 703-696-4240				10. SPONSOR/MONITOR'S ACRONYM(S)	
				11. SPONSOR/MONITOR'S REPORT NUMBER(S)	
12. DISTRIBUTION/AVAILABILITY STATEMENT APPROVED FOR PUBLIC RELEASE; DISTRIBUTION UNLIMITED.					
13. SUPPLEMENTARY NOTES					
14. ABSTRACT Calls for transforming government and creating entrepreneurial cultures in non-profit motivated organizations are everywhere today. The primary method proposed for instilling an entrepreneurial mindset is to institute “best practices” or “lessons learned” from commercial firms that have characteristics similar to those of large government organizations. While the similarities between the private and public sector organizations are many, the differences (e.g. legal restrictions, missions, and motivation of members of the organization) are also notable. This exploratory study seeks to more clearly define the commonalities between the experiences of private sector firms and how those experiences can be captured to help DoD organizations to transform themselves to better execute their mission. The gathered data is analyzed for potential antecedents for, barriers to, and outcomes of the implementation of an entrepreneurial mindset in large, global, highly structured commercial firms that have instituted an entrepreneurial culture. It then analyzes the findings to determine the potential applicability of the guidance for actual implementation in government organizations.					
15. SUBJECT TERMS Corporate Entrepreneurship, Intrapreneurship, Corporate Renewal Entrepreneurship, Entrepreneurial Orientation, Entrepreneurial Mindset, Government					
16. SECURITY CLASSIFICATION OF:			17. LIMITATION OF ABSTRACT	18. NUMBER OF PAGES	19a. NAME OF RESPONSIBLE PERSON
a. REPORT	b. ABSTRACT	c. THIS PAGE			Timothy S. Reed, Major, USAF (AFIT/ENV)
U	U	U	UU	195	19b. TELEPHONE NUMBER (Include area code) (937) 255-3636, ext 4799; e-mail: Timothy.Reed@afit.edu

