

Air Force Institute of Technology

AFIT Scholar

Theses and Dissertations

Student Graduate Works

3-20-2008

Selecting the Best Thermal Building Insulation Using a Multi-Attribute Decision Model

Theodore J. Sotoropolis

Follow this and additional works at: <https://scholar.afit.edu/etd>



Part of the [Construction Engineering and Management Commons](#), and the [Environmental Design Commons](#)

Recommended Citation

Sotoropolis, Theodore J., "Selecting the Best Thermal Building Insulation Using a Multi-Attribute Decision Model" (2008). *Theses and Dissertations*. 2838.

<https://scholar.afit.edu/etd/2838>

This Thesis is brought to you for free and open access by the Student Graduate Works at AFIT Scholar. It has been accepted for inclusion in Theses and Dissertations by an authorized administrator of AFIT Scholar. For more information, please contact AFIT.ENWL.Repository@us.af.mil.



**SELECTING THE BEST THERMAL BUILDING INSULATION USING A
MULTI-ATTRIBUTE DECISION MODEL**

THESIS

Theodore J. Sotoropolis, Captain, USAF

AFIT/GEM/ENV/08-M17

**DEPARTMENT OF THE AIR FORCE
AIR UNIVERSITY**

AIR FORCE INSTITUTE OF TECHNOLOGY

Wright-Patterson Air Force Base, Ohio

APPROVED FOR PUBLIC RELEASE; DISTRIBUTION UNLIMITED

The views expressed in this thesis are those of the author and do not reflect the official policy or position of the United States Air Force, Department of Defense, or the United States Government.

AFIT/GEM/ENV/08-M17

**SELECTING THE BEST THERMAL BUILDING INSULATION USING A
MULTI-ATTRIBUTE DECISION MODEL**

THESIS

Presented to the Faculty

Department of Engineering

Graduate School of Engineering and Management

Air Force Institute of Technology

Air University

Air Education and Training Command

In Partial Fulfillment of the Requirements for the
Degree of Master of Science in Engineering Management

Theodore J. Sotoropolis

Captain, USAF

March 2008

APPROVED FOR PUBLIC RELEASE; DISTRIBUTION UNLIMITED

**SELECTING THE BEST THERMAL BUILDING INSULATION USING A
MULTI-ATTRIBUTE DECISION MODEL**

Theodore J. Sotoropolis

Captain, USAF

Approved:

//SIGNED//

Alfred E. Thal, Jr., PhD (Chairman)

20 March 2008
Date

//SIGNED//

Shane A. Knighton, Major, USAF, Ph.D. (Member)

20 March 2008
Date

//SIGNED//

John R. Volcheck, Captain, USAF (Member)

20 March 2008
Date

Abstract

Thermal building insulation has traditionally been viewed as a means to reduce thermal conductivity through the building envelope. Builders typically choose the least expensive material which meets the specifications in order to remain competitive. Other factors regarding long term health and environmental consequences are typically dismissed. However, a recent shift toward sustainability requires that architects and engineers take a more environmentally conscious approach to building design. This research used a holistic approach to selecting thermal building insulation by developing a multi-attribute decision model.

Several types of insulating products from a variety of manufacturers were investigated in order to determine the best insulation alternative for a new Air Force Institute of Technology (AFIT) academic facility at Wright-Patterson Air Force Base based upon the objectives of an Air Force decision-maker. Human health and environmental impacts were considered in addition to those traditionally associated with thermal building insulation. A multi-attribute decision model was chosen for this research because of the numerous alternatives and competing objectives.

The results show that polystyrene ranks highest according to value; however, polystyrene has the highest upfront cost. Wet spray cellulose ranks lower according to value, but its low upfront cost gives it the highest value per cost ratio in climate zone 3.

Acknowledgments

I would like to thank my committee chair, Dr. Al Thal, and committee members Major Shane Knighton, and Captain John Volcheck for their support and guidance in this research effort. Dr. Thal introduced me to the topic of holistic thinking, which led me to this thesis topic. Major Knighton provided extensive knowledge on the theory of decision analysis. Captain Volcheck provided the much needed assistance on mechanical engineering issues. Additionally, I would like to thank Mr. Bradley Gale for his assistance as the decision-maker.

I would be remiss if I did not mention my deep appreciation for the love and support I received from my children. I could not have accomplished this endeavor without their support.

Table of Contents

	Page
Abstract.....	iv
Acknowledgments.....	v
Table of Contents.....	vi
List of Figures.....	ix
List of Tables.....	xii
Chapter 1 - Introduction.....	1
1.1 Background.....	2
1.2 Problem Statement.....	7
1.3 Research Objective.....	7
1.4 Research Approach.....	8
1.5 Scope.....	8
1.6 Significance.....	8
1.7 Summary.....	9
Chapter 2 - Literature Review.....	10
2.1 Modes of Heat Transfer.....	10
2.2 R-Value.....	12
2.3 Climate and Energy Consumption.....	16
2.4 Insulation Materials.....	17
2.5 Fundamentals of Life Cycle Analysis.....	21
2.6 Decision Analysis.....	24
2.7 Decision Support Model Framework.....	26
Chapter 3 - Methodology.....	35

	Page
3.1 Problem Identification	35
3.2 Objective Hierarchy.....	36
3.3 Evaluation Measures	44
3.4 Creating Value Functions	52
3.5 Weighting the Hierarchy	56
3.6 Alternative Identification.....	59
Chapter 4 – Results and Analysis	60
4.1 Alternative Scoring.....	60
4.2 Deterministic Analysis	62
4.3 Sensitivity Analysis	69
4.4 Material Cost Per Value Analysis	78
4.5 Comparison of Total Value and Cost per Value.	80
Chapter 5 – Findings and Conclusions	81
5.1 Answer to Research Questions.....	81
5.2 Model Strengths.....	82
5.3 Model Weaknesses	83
5.4 Areas for Future Research	83
5.5 Final Conclusions	84
Appendix A: Monthly Average Temperature	85
Appendix B: Single Dimensional Value Functions	86
Appendix C: Global Weights for Climate Zones 1 and 5.....	92
Appendix D: Sensitivity Analysis of Non-Sensitive Measures	93
Appendix E: Effective R-values for Climate Zones 1 and 5	99

	Page
Bibliography	100

List of Figures

	Page
Figure 1.1. Costs of LEED certification	4
Figure 1.2. Energy savings for LEED certified buildings	4
Figure 1.3. Relationship between sustainability factors	6
Figure 2.1. 200mm Guarded Hot Box Apparatus	13
Figure 2.2. Impact of temperature gradient on thermal resistance of loose-fill fiberglass	14
Figure 2.3. Sensitivity of thermal conductivity with respect to temperature differential	15
Figure 2.4. Number of cooling degree days and heating degree days for climate zones.	16
Figure 2.5. Relationship between energy consumption and heating degree days/day.....	17
Figure 2.6. Horizontal Section of a Typical Brick Wall	19
Figure 2.7. Life Cycle Assessment Summary.....	23
Figure 2.8. Decision model framework	27
Figure 2.9. Job selection value hierarchy.....	29
Figure 2.10. Generic monotonically increasing value function.....	30
Figure 2.11. Generic monotonically decreasing value function	31
Figure 3.1. Insulation Performance Hierarchy.....	38
Figure 3.2. Objective Hierarchy with Evaluation Measures.....	46
Figure 3.3. Effective R-value SDVF.....	53
Figure 3.4. Sound Transmission Class SDVF	54
Figure 3.5. Resistance to Infiltration SDVF	55

	Page
Figure 3.6. Flame Spread SDVF	56
Figure 3.7. Hierarchy with Local Weights (Global Weights).....	58
Figure 4.1. Climate Zone 1 Rankings – Second Tier (Minot, North Dakota)	63
Figure 4.2. Climate Zone 1 Rankings – Measures (Minot, North Dakota)	64
Figure 4.3. Climate Zone 3 Rankings – Second Tier (Dayton, Ohio)	65
Figure 4.4. Climate Zone 3 Rankings – Measures (Dayton, Ohio)	66
Figure 4.5. Climate Zone 5 Rankings – Second Tier (Niceville, Florida).....	67
Figure 4.6. Climate Zone 5 Rankings – Measures (Niceville, Florida).....	68
Figure 4.7. Sensitivity of Material Properties (Climate Zone 3)	71
Figure 4.8. Sensitivity of Environmental Impact (Climate Zone 3)	72
Figure 4.9. Sensitivity of Impact to Human Health (Climate Zone 3)	73
Figure 4.10. Sensitivity of Smoke Generation (Climate Zone 3)	74
Figure 4.11. Sensitivity of Percent Recycled Material (Climate Zone 3).....	75
Figure 4.12. Sensitivity of Percent Hazardous Material (Climate Zone 3)	76
Figure 4.13. Sensitivity of Permeability (Climate Zone 3).....	77
Figure B.1. Smoke Generation SDVF	86
Figure B.2. Embodied Energy SDVF	87
Figure B.3. Percent Recycled Material SDVF.....	88
Figure B.4. Percent Hazardous Material SDVF.....	89
Figure B.5. Permeability SDVF.....	90
Figure B.6. MSDS Health Rating SDVF	91

	Page
Figure D.1. Sensitivity of Effective R-Value (Climate Zone 3).....	93
Figure D.2. Sensitivity of Sound Transmission Class (Climate Zone 3).....	94
Figure D.3. Sensitivity of Resistance to Infiltration (Climate Zone 3).....	95
Figure D.4. Sensitivity of Flame Spread (Climate Zone 3).....	96
Figure D.5. Sensitivity of Embodied Energy (Climate Zone 3).....	97
Figure D.6. Sensitivity of MSDS Health Rating (Climate Zone 3).....	98

List of Tables

	Page
Table 2.1. Properties of insulating materials	21
Table 2.2. Types of approaches to decision problems (Bouyssou et. al., 2006).....	25
Table 2.3. List of Measures in Order from Most Important to Least Important.....	32
Table 3.1. Evaluation measures	45
Table 3.2. Weights for Climate Zone 3 (Dayton Ohio).....	57
Table 4.1. Matrix of hierarchy measure scores (Dayton, Ohio)	61
Table 4.2. Cost per Value of Alternatives – Minot, North Dakota (RSMMeans, 2005).....	78
Table 4.3. Cost Per Value of Alternatives – Dayton, Ohio.....	79
Table 4.4. Cost Per Value of Alternatives – Niceville, Florida	79
Table A1: Average Monthly Temperatures – Minot, North Dakota	85
Table A2: Average Monthly Temperatures – Dayton, Ohio	85
Table A3: Average Monthly Temperatures – Niceville, Florida.....	85
Table C.1. Weights for Climate Zone 1 (Minot North Dakota).....	92
Table C.2. Weights for Climate Zone 5 (Niceville Florida).....	92
Table E.1. Effective R-values for Climate Zones 1 and 3	99

SELECTING THE BEST THERMAL BUILDING INSULATION USING A MULTI-ATTRIBUTE DECISION MODEL

Chapter 1 - Introduction

Although the United States has less than 5 percent of the world's population, Americans consume 22 percent of the world's energy production (DOE, 2007; DOC, 2007). U.S. energy consumption is led by the federal government, which consumed 1,067 trillion British Thermal Units (BTUs) in fiscal year 2006. This is largely due to the activities of the Department of Defense (DoD), which consumed 844 trillion BTUs in fiscal year 2006 (DOE, 2007).

On a global scale, 50 percent of the world's energy consumption is attributed to buildings (Filippin and Beascochea, 2007). In the United States, heating and cooling of commercial and residential buildings accounted for 32 percent of the total energy consumption of those buildings in 2005 (DOE, 2007). While high-efficiency heating and cooling systems are designed to reduce energy consumption, these systems will not achieve the desired goals if the building envelope does not effectively reduce heat transfer. The building envelope consists of the windows, wall systems, doors, insulation, foundation, and roofing (DOE, 2007); it is the combination of building materials which separate the inside of the building from the outside. While all building envelope components provide some thermal resistance, thermal insulation is typically the largest contributor to the total thermal resistance of a building envelope. Yet, selections of the appropriate type of insulation to install are rarely given much thought.

1.1 Background

Before presenting the formal problem statement and research questions for this effort, it is important to have a good understanding of some of the key issues. Therefore, the remainder of this section will briefly discuss energy reduction efforts, sustainability, and life-cycle concepts.

1.1.1 Energy Consumption Reduction Initiatives

In January 2007, President George Bush signed Executive Order 13423, which requires federal agencies to reduce energy consumption by three percent per year for the next ten years to reduce greenhouse gas (GHG) emissions. In order to comply with the order, agencies within the federal government signed the Federal Leadership in High Performance and Sustainable Buildings Memorandum of Understanding (MOU). The purpose of the MOU (2006) was to establish a common set of principles for sustainable building design. This will have a significant impact on the nation's energy consumption because the federal government owns 445,000 buildings with over three billion square feet (MOU, 2006).

Additionally, the United States Department of Energy (DOE) has partnered with the private sector and local governments to improve building efficiency through the creation of the National Institute of Building Sciences (NIBS) (U.S. Congress, 1974). NIBS oversees the Whole Building Design Guide (WBDG), which is a web-based guide that provides the government and private sector access to current information regarding new building technologies. A key aspect of the WBDG is improving the performance of the building envelope, which is measured by numerous criteria that include structural

aspects, climate control, energy conservation, sound attenuation, fire safety, security, maintainability, constructability, durability, aesthetics, and economy (NIBS, 2007).

Many of the design recommendations of the WBDG have been included in the Unified Facilities Criteria (UFC) which outlines DoD facility design requirements.

Energy consumption reducing initiatives are not limited to the federal government. The United States Green Building Council (USGBC), which is a non-profit organization, has developed the Leadership in Energy and Environmental Design (LEED) program. LEED is the nationally accepted benchmark of efficient building design and encourages businesses and individuals to construct buildings in a more environmentally responsible manner. The program is based on the whole building design concept. There are four levels of LEED certification which are differentiated by the number of points attained in various categories.

LEED certification comes at a small premium when compared to the long-term benefits which include reduced energy and water consumption, reduced waste, improved indoor air quality, and lower maintenance costs. The average upfront cost of LEED certification is presented in Figure 1.1 and energy savings are presented in Figure 1.2. Although beneficial, the program has received criticism because the point-based rating system lacks a measure for long-term performance (Bowen, 2007).

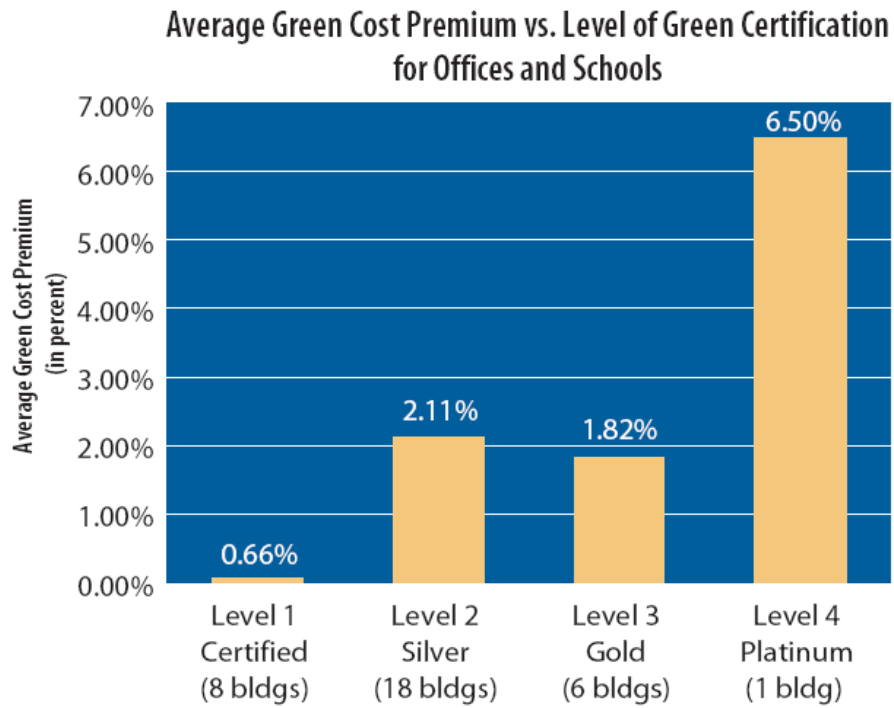

Figure 1.1. Costs of LEED certification (Katz, 2003)

Reduced Energy Use in Green Buildings as Compared with Conventional Buildings

	Certified	Silver	Gold	Average
Energy Efficiency (above standard code)	18%	30%	37%	28%
On-Site Renewable Energy	0%	0%	4%	2%
Green Power	10%	0%	7%	6%
Total	28%	30%	48%	36%

Figure 1.2. Energy savings for LEED certified buildings (Katz, 2003)

1.1.2 Sustainability

The concept of sustainability is not new. Perhaps the most notable reference to unsustainable societies is Thomas Malthus' article titled, "An Essay on the Principle of Population." Written in 1798, the essay proclaimed that unchecked population growth would outpace food supply increases, thereby resulting in widespread famine. Another prominent article regarding unsustainable growth was written in 1968 by Garret Hardin called "The Tragedy of the Commons." The article illustrates the need to limit access to, and the consumption of, natural resources in order to protect them. Based on the claims of Malthus (1798) and Hardin (1968), the current path of technology driven population growth is unsustainable unless there is a conscious shift toward holistic thinking. The concept of sustainability, illustrated in Figure 1.3, is a balance of social, environmental, and economic needs.

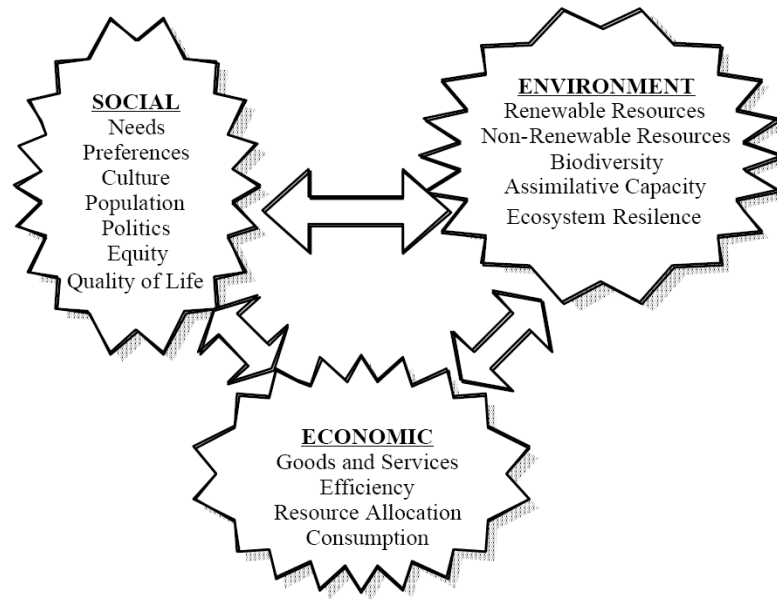

Figure 1.3. Relationship between sustainability factors (Vanegas et al., 1996)

1.1.3 Life-Cycle Analysis

From an environmental standpoint, energy consumption is an important factor; however, there are additional factors which affect the environment and the health of individuals which must be considered in order to reach sustainability. One such factor is insulation, which is the focus of this thesis effort. Life-cycle studies found in the literature involving insulating materials have included factors such as energy consumption, solid waste, GHG emissions, toxicity, and air pollutants. The values for these categories include input from acquiring and processing the raw materials as well as transporting the product.

Life-cycle analysis is defined by the International Organization for Standardization (ISO) 14000 family of international standards on environmental management as a systematic tool for assessing the environmental impacts associated with

a product or service (ISO 140341, 1998). A life-cycle analysis typically consists of taking an inventory of contributing factors and then converting the data into common units. Quantifying the overall impact provides a holistic view of a product or service. This holistic approach allows a decision-maker to make more informed decisions as well as evaluate and improve processes.

1.2 Problem Statement

Selecting the best thermal building insulation is a complex decision. Recent research indicates that the R-value is not an accurate measure of thermal performance in all climates (Budaiwi, Abdou, and Al-Homoud, 2002). Additionally, a shift toward sustainability requires that engineers approach design from a holistic perspective. Unfortunately, the decision regarding which type of insulating material to use is often based on the upfront cost and past practice (Gale, 2007).

1.3 Research Objective

The objective of this research was to determine the best thermal building insulation for a new Air Force Institute of Technology academic building by constructing a decision model which incorporates the decision-maker's values. Specifically, this research attempted to answer the following questions:

1. What insulation alternatives are available?
2. What decision criteria are important to the decision-maker for the focus facility?
3. What is the best insulation alternative for the AFIT academic building in its current location?

4. What insulation alternative provides the highest value per dollar for the AFIT academic building in its current location?
5. What is the best alternative for the academic building in other climates?
6. What insulation alternative provides the highest value per dollar for the AFIT academic building in other climates?

1.4 Research Approach

Complex decisions are best made using a structured approach (Kirkwood, 1997). Furthermore, decision analysis provides the necessary structure to objectively compare alternatives based on important criteria. Therefore, a decision model was developed to evaluate various alternatives against the decision-maker's known criteria. Decision analysis will be described in greater detail in Chapters 2.

1.5 Scope

This research is limited to readily available insulation materials which have published data for the measures identified in the model. Weights and value functions of the decision criteria are a subjective measure based on the decision-maker's knowledge, personal preferences, and background. As such, a professionally licensed mechanical engineer was chosen to evaluate the criteria in this research. The model may yield differing results with an alternate decision-maker.

1.6 Significance

This research provides a strategic decision model which includes all of the decision criteria related to thermal building insulation as provided by the decision-maker.

The results provide a holistic evaluation of the alternatives. Therefore, this research can be utilized by design engineers as demonstration of a repeatable methodology to select the best thermal building insulation for a given facility.

1.7 Summary

The type of thermal building insulation an engineer selects will have a significant impact on the environment, construction workers, and the occupants. An increasing number of alternatives, each with advantages and disadvantages, have complicated the issue. A structured hierarchical approach will enable decision-makers to evaluate and compare alternatives in order to select the alternative which best meets their overall objectives.

Chapter 2 - Literature Review

The purpose of this chapter is to briefly provide relevant background material regarding the research. The chapter will initially cover fundamental concepts of heat transfer; this will include the modes of heat transfer and the concept of the rated thermal conductivity (R-value). The next section will briefly review the impact of climate on energy consumption. This will be followed by a section on insulation materials which will cover types, properties, and performance. The fourth section provides a little more information about life-cycle analysis. Finally, the last two sections review material related to decision analysis.

2.1 Modes of Heat Transfer

Heat transfer is the movement of energy, by way of conduction, convection, and radiation, as a result of a temperature differential in a medium or between media (Incropera and Dewitt, 1996). Furthermore, the rate of energy transfer is directly proportional to the temperature difference across the medium as shown in Equation 2.1 (Turner, 1997),

$$Q = \frac{\Delta t}{Rvalue} \quad (2.1)$$

where Q = energy transfer rate (BTU/hr), Δt = difference in temperature (°F), and $Rvalue$ = thermal resistance (hr·ft²·°F/BTU). Additionally, Equation 2.2 shows that the total energy flow across a medium is equal to the sum of the energy flow of each heat transfer mode (Turner, 1997).

$$Q_{total} = Q_{convection} + Q_{Conduction} + Q_{Radiation} \quad (2.2)$$

2.1.1 Natural Convection

Natural convective heat transfer occurs as a result of temperature differentials within a fluid which causes density variations. Higher density fluids are pulled downward by gravitational forces which displaces lower density fluids. The velocity of natural convection is relatively slow because the forces which act on the fluid are small (Burmeister, 1993). Heat transfer due to natural convection is impeded through the use of building insulation which has tiny air pockets that have small temperature gradients. The small temperature gradients within the cells further reduce the velocity of natural convection (Turner, 1997). Convective heat transfer is described by Equation 2.3,

$$q = h(T - T_{\infty}) \quad (2.3)$$

where q = heat flow rate (BTU/hr), h = convective heat transfer coefficient, T = Temperature (°F), and T_{∞} = Reference temperature (°F).

2.1.2 Conduction

Conduction is the heat transfer through a material without the movement of mass. Conductive heat transfer generally increases as the density of the medium increases. Fourier's law describes the rate at which a material will conduct heat and is shown in Equation 2.4 (Myers, 1971),

$$q_x = -k \frac{dt}{dx} \quad (2.4)$$

where q_x = heat flow rate in the direction of x (BTU/hr), k = thermal conductivity (BTU/hr/ft/°F), t = temperature (°F), and x = length variable (ft).

2.1.3 Radiation

Radiative heat transfer is the exchange of thermal energy caused by electromagnetic waves. Furthermore, a medium does not need to exist for radiative heat transfer to occur (Siegel and Howell, 1992). Radiation can penetrate insulation which can increase the temperature gradient across the building envelope and speed the overall heat transfer (Siegel and Howell, 1992). Wavelengths between 10^{-7} m and 10^{-3} m, which include ultraviolet, visible, and infrared electromagnetic waves, are of the greatest importance to heat transfer. Additionally, the wave strength of the emitting material is dependent on its temperature (Modest, 1993).

The combination of radiant heat flux, conduction, and convection leads to nonlinear differential equations that are difficult to solve (Siegel and Howell, 1992). Reflective properties of the receiving material further complicate the quantification of radiative heat transfer. Radiative heat transfer is calculated using Equation 2.5 (Siegel and Howell, 1992),

$$q_r = \int_S q_s dS + \int_V q_v dV \quad (2.5)$$

where S = surface type, V = volume of radiative material, q_s = radiant energy arriving at surface element, and q_v = radiant energy arriving from unit volume element.

2.2 R-Value

The R-value of an insulating material is measured by American Standards of Testing and Materials (ASTM) test method C236-89. The test is conducted by placing a specimen in a guarded hot box, shown in Figure. 2.1, and heating it until it reaches a

steady-state temperature of 24 degrees Celsius. The amount of energy required to keep the material at steady-state is used to calculate the thermal conductivity.

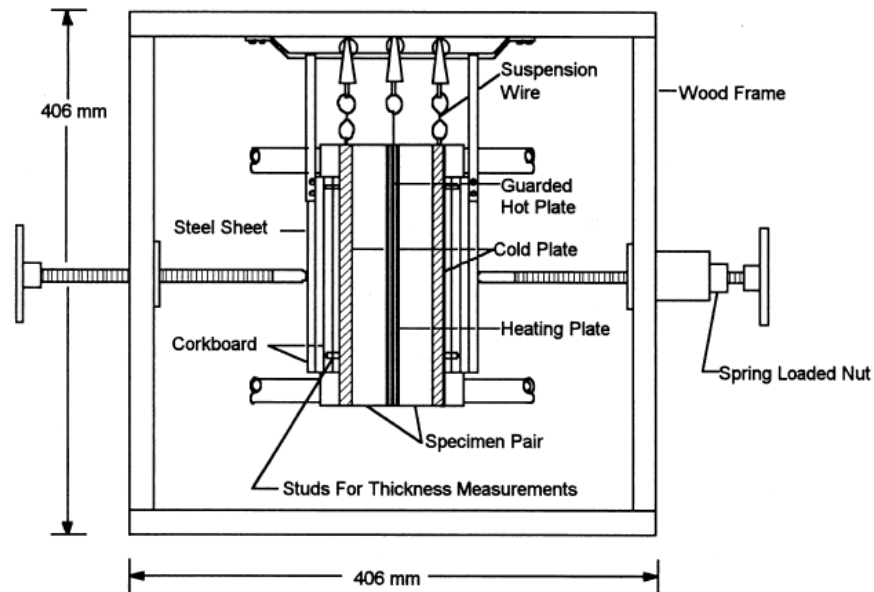

Figure 2.1. 200mm Guarded Hot Box Apparatus (Zarr, 2001)

According to Equation 2.3, the amount of energy which is transferred through convection is directly proportional to the difference in temperature across the sample. As previously mentioned, the velocity of the energy transfer increases as the temperature gradient increases. Therefore, a steady-state test ignores the impact of the increasing velocity, and the resulting heat transfer, under extreme conditions. In addition, the sun is a significant source of thermal radiation. The sun emits electromagnetic waves in ultraviolet radiation, visible light, and infrared radiation (WHO, 1999). The guarded hot box does not duplicate the radiation of the sun. Therefore, the steady-state test is not an accurate measure of an insulating material's thermal conductivity in realistic conditions.

In fact, recent research reveals the inaccuracies of the ASTM test. The Oak Ridge National Laboratory tested loose-fill attic insulations under simulated winter conditions and found that the R-value of loose-fill fiberglass was consistent with the rated R-value in the presence of a 22 degree Fahrenheit differential. However, a 53 degree Fahrenheit temperature differential resulted in a 28 percent decrease in R-value and a 62 degree Fahrenheit gradient resulted in a 51 percent lower R-value. Additional data points were taken for 2 samples and are shown in Figure 2.2 (Graves, Wilkes, and McElroy, 1994). The samples were installed to ASTM standards and tested in a large scale climate simulator. The density of the samples was approximately 8.7 kg/m^3 .

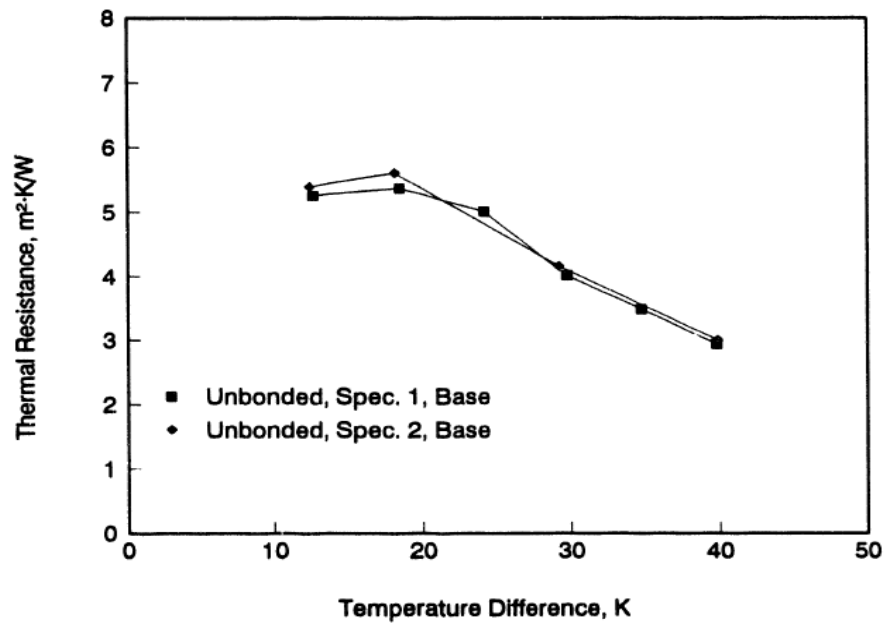

Figure 2.2. Impact of temperature gradient on thermal resistance of loose-fill fiberglass (Graves, Wilkes, and McElroy, 1994)

The results of the Oak Ridge research were supported by experiments conducted using a guarded hot plate apparatus and included a wide range of insulating materials from various manufacturers with varied densities (Graves, Wilkes, and McElroy, 1994). However, the experiment simulated an extremely hot climate rather than winter conditions. The researchers concluded that thermal conductivity varies with operating temperature for all materials tested and that a larger temperature gradient results in higher thermal conductivity. The results, shown in Figure 2.3, are summarized based on the variation of thermal conductivity per degree Celsius. Polyurethane and polystyrene had the lowest rate of change while polyethylene and wood wool had much greater rates of change (Budaiwi, Abdou, and Al-Homoud, 2002).

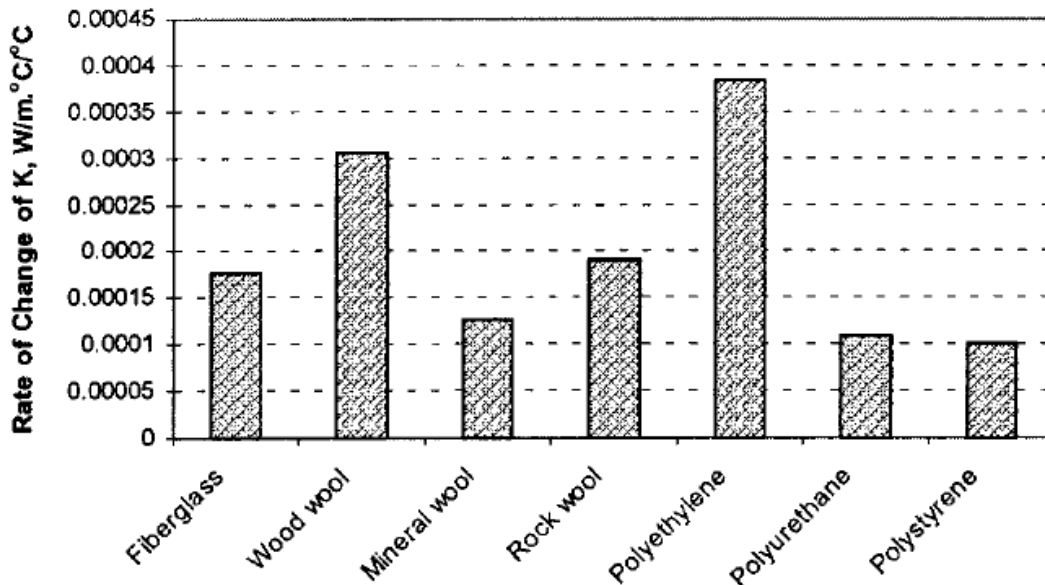

Figure 2.3. Sensitivity of thermal conductivity with respect to temperature differential (Budaiwi et al., 2002)

2.3 Climate and Energy Consumption

Climate has a substantial impact on a building's energy consumption. According to the Department of Energy (DOE), the United States has 5 climate zones, shown in Figure 2.4, which are differentiated by heating degree days and cooling degree days (DOE, 2007). A heating degree day is the difference between the expected average daily temperature and 65 degrees Fahrenheit. For example, given an average temperature of 40 degrees Fahrenheit, the heating degree day value for that day is 25; cooling degree days are calculated similarly. These daily values are often summed to provide a yearly value. Furthermore, the correlation between heating degree days and energy consumption is 0.97 and is shown in Figure 2.5. The AFIT academic building used in this research is located in climate zone 3 (DOC, 2002).

Climate Zone	Cooling Degree Days	Heating Degree Days
1	Fewer than 2,000	More than 7,000
2	Fewer than 2,000	5,500 to 7,000
3	Fewer than 2,000	4,000 to 5,499
4	Fewer than 2,000	Fewer than 4,000
5	2,000 or More	Fewer than 4,000

Figure 2.4. Number of cooling degree days and heating degree days for climate zones (DOE, 2007)

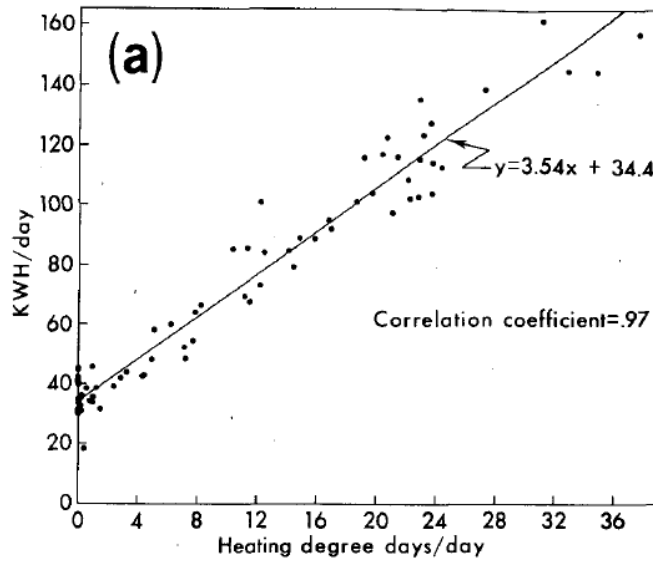

Figure 2.5. Relationship between energy consumption and heating degree days/day (Quayle and Diaz, 1979)

2.4 Insulation Materials

There are a variety of thermal building insulation materials which come in various forms. Rock wool, also called mineral wool, is made from natural minerals and was developed in the mid-1800s (NAIMA, 2008). Fiberglass is a form of mineral wool and accounts for approximately 85% of the market for residential insulation. Synthetic insulating materials include expanded polyurethane and polystyrene foam. In addition to these alternatives, there are natural fiber products which include cotton and cellulose. Cotton insulation products are typically manufactured using the scraps from the textile industry and cellulose is manufactured from recycled paper. Natural and synthetic materials are treated to improve fire resistance. These alternatives are available in various forms for a variety of applications. Aside from thermal resistance, insulating materials have various properties which can have a substantial impact on long-term operating costs, noise transmission, occupant, and worker safety.

2.4.1 Infiltration

Infiltration is the uncontrolled process of air and water vapor traveling through the building envelope (Chebil, Galanix, and Zmeureanu, 2002). Air exiting the building is sometimes called exfiltration; however, the terms are used interchangeably in the literature. Unrelated to the direction of infiltration, there are two types of infiltration. The first form is when air bypasses the building envelope through gaps between building materials. Figure 2.6 shows the cavities within the wall system by which air leakage can bypass insulation. The second form of infiltration is water vapor which travels through building materials as a result of slight differences in vapor pressure. Regardless of the type, infiltration has a significant impact on the operating cost of a building (Morgan, 2006). Additionally, construction quality and material selection has a considerable impact on the quantity of infiltration. Insulation is of particular interest because an estimated 20 percent to 50 percent of air leakage is through walls (PCI, 2005).

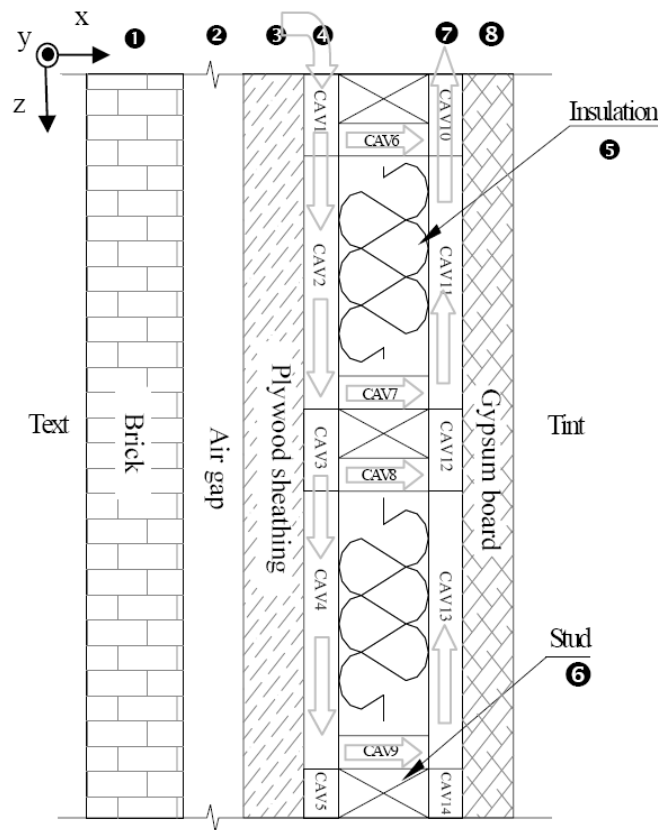

Figure 2.6. Horizontal Section of a Typical Brick Wall (Chebil, et. al., 2002)

2.4.2 Sound Attenuation

Insulation reduces sound transmittance by breaking the path of sound waves. Excessive noise transmittance can negatively impact worker productivity and quality of life. Sound attenuation is of particular importance in an academic setting because excessive noise reduces learning ability (CHPS, 2006). An un-insulated standard wood stud wall with half inch drywall on both sides will have an STC rating of approximately 33. The same wall system with insulation will have a STC rating of 39 or higher.

2.4.3 Fire Resistance

Fire poses a considerable risk to the building occupants. According to the National Fire Protection Association (NFPA), there were 511,000 structure fires reported in 2005 which resulted in 17,925 injuries and 3,105 deaths (NFPA, 2006). The type of materials used to construct a building can have a significant impact on the occupants in the event of a fire. There are two main concerns with respect to the burn characteristics of a building material: the speed at which a flame will spread and the density of the resulting smoke.

2.4.4 Risk to Human Health

In addition to fire, there are risks to human health as a result of exposure during construction. Fibrous materials can become airborne during handling. While protective equipment can be worn to mitigate the risk, studies indicate that people who manufacture fiberglass have 60% more fiberglass material in their lungs than those who had not been exposed (McDonald et al., 1990). The Material Safety Data Sheet categorizes the risks associated with handling of materials. The performance characteristics for fire rating, infiltration, and sound attenuation are shown in Table 2.1 (Al-Homoud, 2005).

Table 2.1. Properties of insulating materials (Al-Homoud, 2004)

Material	Form	Fire Rating	Infiltration	Sound Attenuation
Fiberglass	Batt/Roll	Good	Poor/Fair	High
Rock Wool	Batt/Roll	Excellent	Poor/Fair	Very High
Polyethylene	Batt/Roll	Poor	Good	N/A
Fiberglass	Loose-Fill	Very Good	Poor	High
Rock Wool	Loose-Fill	Excellent	Poor	Very High
Cellulose	Loose-Fill	Very Good	Poor	Low
Perlite	Loose-Fill	Excellent	Poor	Low
Vermiculite	Loose-Fill	Very Good	Good	Low
Fiberglass	Rigid Board	Good	Good	Medium
Expanded Polystyrene	Rigid Board	Poor	Good	Low
Extruded Polystyrene	Rigid Board	Poor	Very Good	Low
Polyurethane	Rigid Board	Poor	Excellent	Low
Perlite	Rigid Board	Excellent	Excellent	Low
Vermiculite	Rigid Board	Excellent	Excellent	Low
Cellulose	Sprayed in Place	Very Good	Excellent	Low
Polyurethane	Foamed in Place	Poor	Excellent	Low

2.5 Fundamentals of Life Cycle Analysis

Life cycle analysis (LCA) uses a systems approach to identify the cradle-to-grave environmental impact of a material (Bishop, 2004). These studies provide a holistic view of the alternatives in terms of the overall impact each material has on the environment. A typical LCA may include following life cycle stages:

1. Raw materials and energy acquisition.

2. Manufacturing, including intermediate materials, transportation, fabrication, packaging, and distribution.
3. Use/reuse/maintenance by the consumer during the product's useful life.
4. Recycle/waste management after use.

These studies are valuable in order to make quantitative comparisons between materials which in turn can be utilized to identify areas in which the manufacturing techniques could be modified to reduce the overall environmental burden (Bishop, 2004). An LCA can also be utilized by designers in selecting materials which best meet design criteria. According to the Society of Environmental Toxicology and Chemistry (SETAC), the principle components of an LCA are life cycle inventory assessment, impact assessment, and improvement assessment. A fourth component which is interrelated to these is goal definition and scoping.

Inventory analysis quantifies energy and raw material requirements, atmospheric emissions, waterborne emissions, solid wastes, and other releases for the entire life cycle of a product, package, process, material or activity (Curran, 1996). The inventory analysis consists of defining the scope, data gathering, creating a computer model, impact analysis, and interpretation of the results (Bishop, 2004). Defining the scope is a continuation of the fourth component of the LCA. Data gathering requires collecting comprehensive information which can be problematic because of resource constraints such as proprietary information. Additionally, manufacturing processes can vary greatly which can result in inaccuracies. An LCA is only as good as the data. The lack of a complete data set may result in a faulty analysis. Once the data is gathered and put into equivalent units, computer programs and spreadsheets can be utilized to determine the overall environmental impact. Reports should focus on essential information to avoid

confusion. Graphical representations are extremely beneficial. Interpretation of the results should focus on ways to reduce resources and energy use.

Impact analysis is either a quantitative or qualitative examination of potential impact on humans or the environment (Bishop, 2004). This stage can be problematic as well because of a lack of understanding regarding the specific impact associated with some values. Researchers should consider a system to convert the data to a structure which can be adjusted for a variety of production techniques. Finally, the purpose of interpreting the results is to ascertain areas to reduce energy, raw materials, and emissions, which can then be used to develop strategies for minimizing impact (Bishop, 2004).

Researchers who conducted an LCA on fiberglass, cotton, and blown cellulose separated information into categories which included energy requirements, solid waste, global warming potential, carbon dioxide emissions, acidification, eco-toxicity, and criteria air pollutants (Chang, Scheuer, and Swenson, 2001). The results of the study are summarized in Figure 2.7.

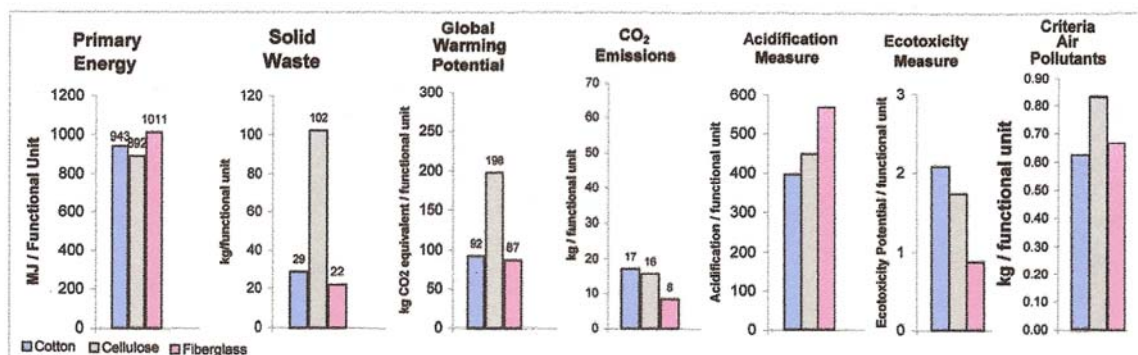

Figure 2.7. Life Cycle Assessment Summary (Chang, et. al., 2001)

2.6 Decision Analysis

Determining the best insulation using a holistic approach is more difficult than simply selecting an insulating material which meets code and budget requirements. In fact, there are trade-offs that must be considered because the decision problem has multiple competing objectives. Therefore, multiple-objective decision analysis is the most appropriate method to solve this decision problem. The rationale for selecting multiple-objective decision analysis is best explained by describing the theory of decision analysis as well as the other methods that are used to solve the various types of decision problems. Consequently, the following sections begin with an overview of the various approaches to decision analysis and the applicability of decision analysis in selecting an insulating material. This is followed by a summary of the technique utilized in this research, multiple-objective decision analysis. The decision support model for the insulation decision problem will also be discussed in this section.

2.6.1 Introduction to Decision Analysis

Complex decisions should be analyzed strategically in order to maximize the probability of a favorable outcome (Bouyssou, Marchant, Pirlot, Tsoukias, and Philippe, 2006). A strategic or structured approach ensures that all important aspects regarding the decision have been considered. However, the rationale behind a decision varies depending on the preferences of the decision-maker and the type of available information. Based on the characteristics of the decision problem, four distinct approaches are available which are called normative, descriptive, prescriptive, and constructive. The differences between these approaches are shown in Table 2.2.

Table 2.2. Types of approaches to decision problems (Bouyssou et. al., 2006)

Approach	Characteristics	Process to obtain the model
Normative	Exogenous rationality, ideal economic behaviour	To postulate
Descriptive	Exogenous rationality, empirical behaviour models	To observe
Prescriptive	Endogenous rationality, coherence with the decision situation	To unveil
Constructive	Learning process, coherence with the decision process	To reach a consensus

2.6.2 Applicability of the Prescriptive Approach

New technologies have resulted in an increase in building material alternatives. Additionally, recent shifts to holistic thinking have increased the amount of available information regarding these alternatives. Consequently, selecting building materials has become increasingly complicated because of multiple competing objectives which require a more structured approach to ensure the best alternative is selected. The prescriptive approach is well suited for this research because a structured model will unveil the decision-maker's preferences.

Variations of the prescriptive approach include Value Focused Thinking (VFT) and Alternative Focused Thinking (AFT). The first step in VFT is to determine the goal and then to determine how to achieve the goal (Keeney, 1992), whereas AFT centers on the alternatives and then the criteria by which the alternatives are to be evaluated are considered. The difference between AFT and VFT is subtle. However, if the alternatives are unknown, the decision-maker and the analyst must focus on the overall objective. This is not necessarily the case if the alternatives are fixed. By focusing on the overall

goal, more attention may be given to identifying means objectives which will help reach the overall goal (Keeney, 1992). However, it should be possible for the decision-maker and analyst to disregard the alternatives while determining the means objectives.

Multiple-objective decision analysis has been applied to recent research on building design and material selection because decisions have become more complex. Models to optimize energy efficient building renovations and roofs are just a couple of recent examples (Pratt, 2006; McCourt, 2007). Pratt (2006) evaluated a variety of retrofits to existing buildings based on the impact to the building envelope. The model illustrates the advantages of various types of windows, roofs, and walls, and roofs. Furthermore, the model allows a decision-maker to compare alternatives under various climate conditions. McCourt (2007) developed a model which focused specifically on energy efficient technologies for low-sloped roofs. A variety of types of roofing materials under various climate conditions were considered. This research has similar characteristics, such as a wide variety of materials for which differing climate conditions will have varied impact on building efficiency.

2.7 Decision Support Model Framework

Value Focused Thinking consists of a ten-step process which is shown in Figure 2.8. A general overview of these steps is provided in the remainder of this section; the execution of these steps for this research effort will be presented in Chapters 3 and 4.

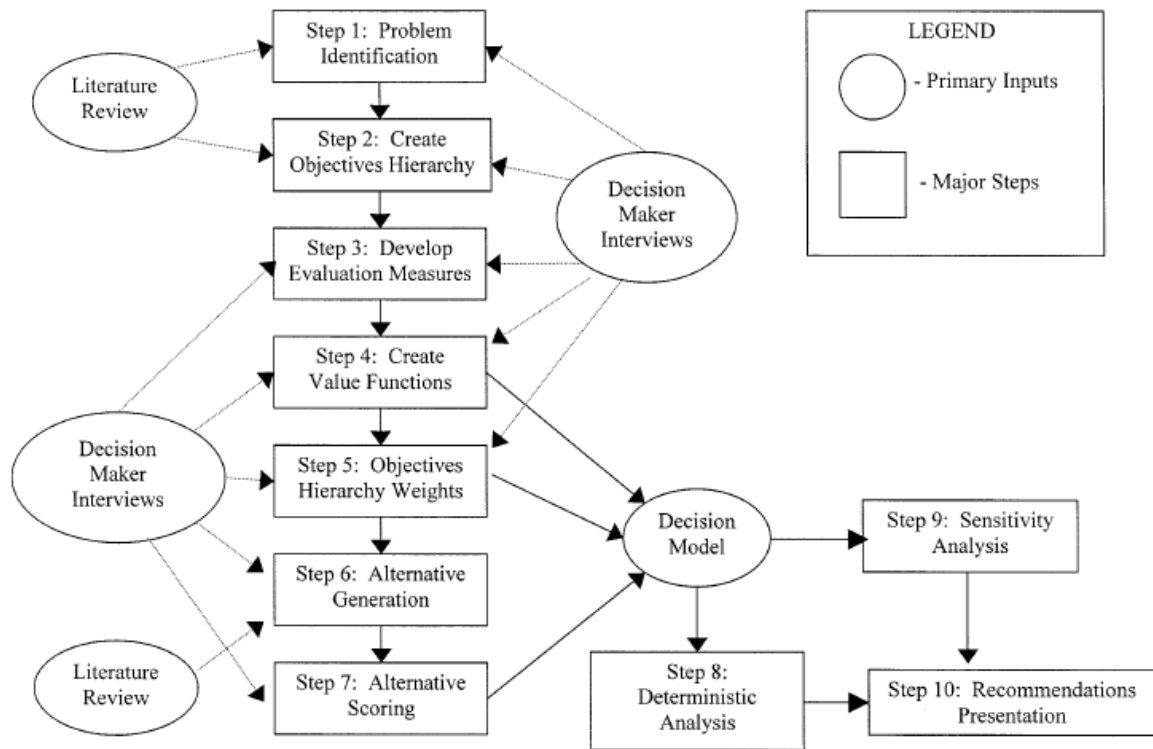

Figure 2.8. Decision model framework (Shoviak, 2001)

2.7.1 Identify the Problem

Step one, recognizing the problem, is a fundamental part of solving any decision problem (Kirkwood, 1997). Otherwise, the decision-maker will not be able to determine the objectives necessary to build an accurate model. Solving the wrong problem serves only to address the symptoms of the problem which wastes time and money.

2.7.2 Create Objective Hierarchy

The next step in VFT is the creation of a hierarchy of objectives (Kirkwood, 1997). This is accomplished by determining the overall goal and identifying objectives which are important to meeting that goal. The objectives are arranged in a hierarchy to

allow the decision-maker and other interested parties to visualize the organizational structure of the model. It is important to note that the properties of the values in the hierarchy must be complete, non-redundant, independent, operable, and are of small size (Kirkwood, 1997). Completeness requires that the values include all the criteria which are important to the decision-maker. Additionally, the values within the same layer of the hierarchy must not overlap. Otherwise, the value will be given a disproportionate amount of consideration. Values which are independent are not only non-redundant but do not influence the other objectives. An operable hierarchy is easily understood by those who must use it. Hierarchies should also be as small as possible. Communication is easier with a smaller hierarchy than one which is large. An example of a hierarchy is shown in Figure 2.9.

2.7.3 Develop Evaluation Measures

The next step is to develop evaluation measures for each value objective in the lowest tier of the hierarchy (Kirkwood, 1997: 24). The method for assigning an evaluation measure can be through a natural or constructed scale. Evaluation measures which have a quantitative value associated with it will have a natural scale. However, constructed scales must be developed for measures that have qualitative properties. Additionally, scales of evaluation measures are either direct or proxy. “A direct scale directly measures the degree of attainment of an objective, while a proxy scale reflects the degree of attainment of its associated objective, but does not directly measure this” (Kirkwood, 1997).

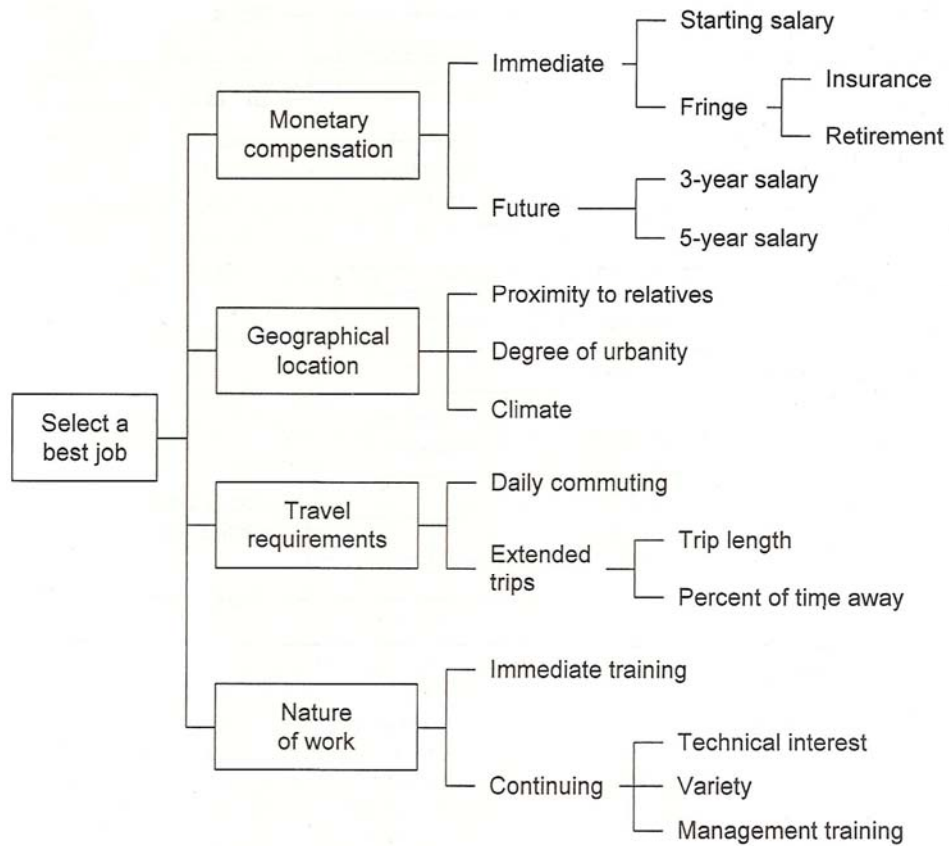

Figure 2.9. Job selection value hierarchy (Kirkwood, 1997)

2.7.4 Create Value Functions

Now that the evaluation measures have been developed, one must create a value function for each measure (Kirkwood, 1997). The value function provides a means to evaluate each measure on a scale from 0 to 1 with 0 being the worst and 1 being the best. This allows all measures to be evaluated on the same unitless scale. An additional step allows the decision-maker to place differing values for various increments within the range. For instance, referencing the job selection hierarchy, salary might range from \$70,000 to \$120,000 which can be easily divided into five \$10,000 increments. The

decision-maker may feel that the difference between \$70,000 and \$80,000 is more valuable than the difference between \$80,000 and \$90,000 because the decision-maker's lifestyle can be maintained with an income of \$80,000. Therefore, additional income is not necessary. Examples of generic value functions can be found in Figures 2.10 and 2.11. Figure 2.10 represents value functions which are marginally increasing, while Figure 2.11 shows value functions which are marginally decreasing. Piecewise linear value functions, not shown, are connected line segments with varied slopes. It should be noted that value functions must be continuously increasing or continuously decreasing throughout the evaluation measure's entire range.

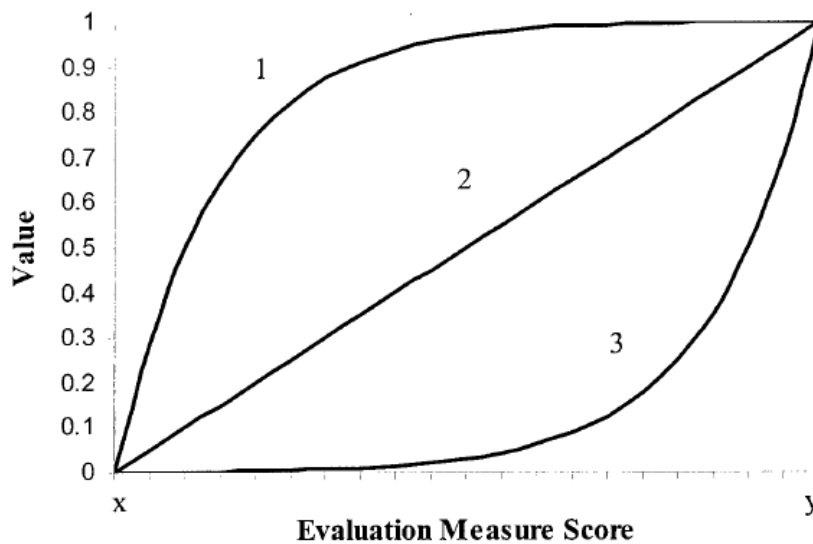

Figure 2.10. Generic monotonically increasing value function (Kirkwood, 1997)

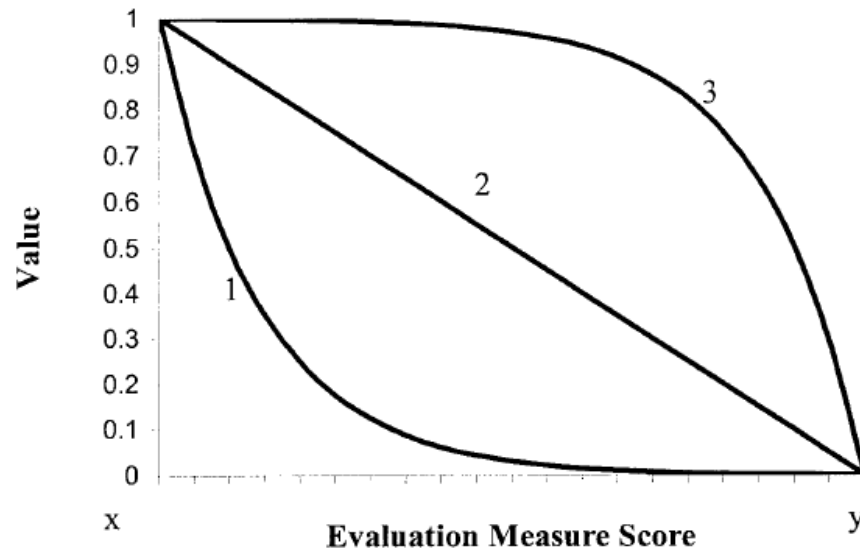

Figure 2.11. Generic monotonically decreasing value function (Kirkwood, 1997)

2.7.5 Weights for Objectives

In addition to applying value functions, the evaluation measures must be weighted (Kirkwood, 1997). Weighting allows the decision-maker to compensate for the inequities of importance between the objectives. According to Kirkwood (1997), the primary method of determining the weights is to consider the impact of changing the value of each evaluation measure from best to worst. The evaluation measures are then listed in order of greatest impact to least impact. The least important measure is in essence the lowest common denominator and all others are quantitatively scaled as a multiple of the lowest common denominator. An example based on the hierarchy in Table 2.2 may yield the following list:

Table 2.3. List of Measures in Order from Most Important to Least Important

10x	Starting Salary – Most important
8x	3-Year Salary
7x	5-Year Salary
5x	Insurance
5x	Retirement
5x	Proximity to Relatives
4x	Climate
4x	Daily Commuting
3x	Trip Length
2x	Percent of Time Away
2x	Management Training
2x	Variety
2x	Immediate Training
2x	Technical Interest
1x	Degree of Urbanity – Least important

The degree of urbanity is the lowest common denominator and is assigned a value of x . Suppose technical interest, which is the next highest measure, is twice as important to the decision-maker as degree of urbanity. Technical interest would therefore be assigned a value of $2x$. This process is continued with the remaining measures. The value for each of the measures are then summed and set equal to one. For the purposes of this example, values have been applied to each measure and the series of equations below show the steps to calculate the value of x .

$$1x+2x+2x+2x+2x+2x+3x+4x+4x+5x+5x+5x+7x+8x+10x = 62x \quad (2.6a)$$

$$62x = 1 \quad (2.6b)$$

$$x \approx .0161 \quad (2.6c)$$

Solving for x reveals the relative importance of the least important measure. The relative importance of the remaining measures is calculated by multiplying x with the corresponding multiple which was assigned to the measure.

2.7.6 Generate Alternatives

The alternatives used in this research are insulation materials which are commercially available. However, sufficient time should be allocated for determining the available alternatives. Decision problems with alternatives which consist of a combination of options can result in hundreds, or even thousands, of alternatives (Kirkwood, 1997). Additionally, it is not always practical or feasible to evaluate each alternative. In such cases, the analyst may be able to eliminate many of the alternatives based on operational constraints with the use of optimization software.

2.7.7 Scoring the Alternatives

Scoring the alternatives is a matter of collecting the data required by the model for each alternative (Kirkwood, 1997). This can be problematic depending on the number of alternatives and value measures. Time limitations and data availability may further complicate the data gathering process. An alternative does not necessarily have to be discarded if certain data is unavailable if the data can be estimated.

2.7.8 Perform Deterministic Analysis

Now that the model is complete, deterministic analysis can begin by inputting the data into the overall value function (Kirkwood, 1997). Several methods have been developed for calculating the overall value of alternatives and vary depending on a multitude of problem properties. The most appropriate method for this research is the additive value function because the evaluation measures are preferentially independent. The additive value function is shown in Equation 2.7,

$$v(x) = \sum_{i=1}^n \lambda_i v_i(x_i) \quad (2.7)$$

where λ_i = weight of evaluation measure i and $v_i(x_i)$ = value of evaluation measure i .

2.7.9 Perform Sensitivity Analysis

Calculating the value of each alternative does not conclude the process of analyzing the alternatives (Kirkwood, 1997). One must accomplish a sensitivity analysis to illustrate the impact of changes in the weights. A lower ranked alternative, as valued by the model, which is sensitive to one or more values, could become the highest ranked alternative if the weights were slightly modified. In this case, the initial weights should be re-evaluated.

2.7.10 Provide Recommendations

At this point, the analysis is complete and the analyst can present the results and provide recommendations to the decision-maker. The format will depend on the audience, decision-maker, and the content derived from the model.

Chapter 3 - Methodology

Alternative focused thinking (AFT) utilizes multi-attribute preference theory and has been selected as an appropriate method for creating a deterministic decision analysis model for selecting the highest performing thermal building insulation. Chapter 2 discussed the steps of Value Focused Thinking (VFT); however, the process for VFT is substantially similar to that of AFT. Additionally, following the VFT methodology is beneficial because the decision-maker and analyst are more likely to focus on the objective rather than the alternatives. The purpose of this chapter is to identify the decision-maker's overall objective as well as the lower tiered objectives. This chapter also provides the decision-maker's preferences for the weights and value functions assigned to the evaluation measures. Additionally, this chapter describes the method for incorporating the climate zones with the variations measured in thermal conductivity research. Finally, this chapter identifies the alternatives which were considered.

3.1 Problem Identification

Identifying the problem is the first step in decision making. The problem presented in this research is selecting the best thermal building insulation for the new AFIT academic facility currently under construction in Area B of Wright-Patterson Air Force Base, Ohio (USACOE, 2007). The decision-maker for this research is a licensed professional mechanical engineer from the 88th Civil Engineer Directorate. This person was selected because of the educational and professional background.

A series of interviews were conducted with the decision-maker in order to construct the model. During the initial interview the decision-maker identified the overall objective as well as lowered tiered objectives. The decision-maker initially discounted thermal performance as an objective because it was thought to be a constant among all the alternatives. The decision-maker was unaware of the variability of insulation's thermal conductivity as a result of large temperature gradients. The discussion included an explanation of the impact of the variability based on climate and the existing research. The range between the highest and lowest performing materials is approximately 10 percent. From this discussion, the problem statement was identified as:

Which insulating material provides the highest overall value in various climates according to the decision-maker's objectives and concerns and which alternative offers the highest value per dollar of upfront cost?

3.2 Objective Hierarchy

The objective hierarchy is developed from the objectives that are important to the decision-maker. These objectives are then organized in a hierarchy with the overall objective at the top. Specific questions during discussions with the decision-maker included: What is the overall objective? What are the fundamental properties of thermal building insulation that will add to the overall objective? What are the benefits of insulation? What are the adverse effects of insulation? What are a perfect alternative, a terrible alternative, and a typical alternative? The decision-maker identified typical attributes of insulation such as sound attenuation, fire rating, and infiltration. These were placed in a single category which was named material properties. Further discussion led

to the identification of health and environmental objectives. As the meeting progressed, third and fourth tiered objectives were identified and placed under the appropriate higher tier objective. Subsequent meetings were held to identify methods to measure the objectives. The objective hierarchy is shown in Figure 3.1.

The hierarchy is considered complete because it incorporates all of the properties which are important to the decision-maker. Additionally, the hierarchy is non-redundant because none of the values in any tier overlap. Therefore, the hierarchy is mutually exclusive and collectively exhaustive. The hierarchy is also decomposable because none of the values are influenced by each other. The hierarchy is operable because it is understood by those who will use it. Each value and the organization of the structure will be discussed at length in the remainder of this section. It should be noted that the model will have three sets of weights to accommodate differing climate conditions.

The decision-maker's fundamental objective is to determine the insulating material which has the highest value. A secondary goal is to determine the alternative with the greatest value per cost. Therefore, the hierarchy does not include an upfront cost objective. The term value is a description based on the degree of attainment of the decision-maker's objectives. The insulation value, according to the decision-maker, is a function of material properties, the impact to the environment, and the impact on human health. These second-tier objectives were selected because collectively they provide a holistic illustration of the impact insulation has on the world.

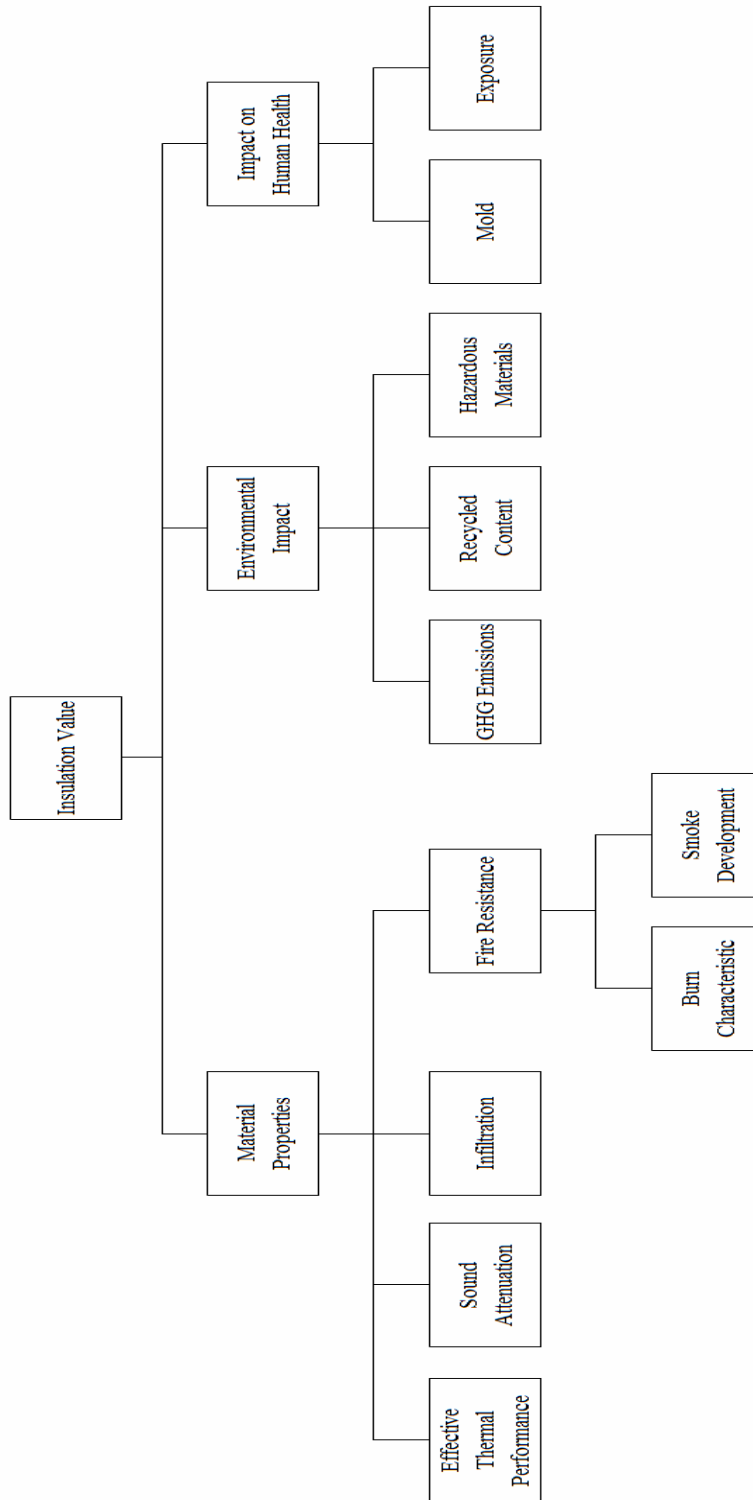

Figure 3.1. Insulation Performance Hierarchy

3.2.1 Material Properties

This second-tier objective includes all of the properties of a material which are traditionally associated with insulation. However, the objective “Material Properties” must be broken down further because there is no single measure that incorporates all of the traditional properties. Third tier values include effective thermal performance, sound attenuation, infiltration, and fire resistance.

3.2.1.1 Effective Thermal Performance

The decision-maker valued effective thermal performance because higher thermal performance will reduce the energy consumption of a building. The standard measure of thermal resistance is in the form of a material’s R-value which is inaccurate and misleading. Effective thermal performance takes into account the effect climate has on a material’s R-value. A material which is sensitive to large temperature gradients will have a lower effective R-value than the R-value attained by the American Society for Testing and Materials (ASTM) test. Therefore, insulating materials which are more stable are preferred over materials which are sensitive. This value is of particular importance in extreme climates.

3.2.1.2 Sound Attenuation

Insulation reduces the amount of outside noise that is transmitted through the building envelope by breaking the path of vibrations. According to the decision-maker, a quiet environment is beneficial to the building occupants, especially in a classroom setting. The structure of the wall will have a significant impact on the amount of sound

which is transmitted. The measure of sound attenuation is called Sound Transmission Class (STC) and is measured using ASTM E90. However, the availability of data for some materials is limited to that of standard wall systems. Therefore, a standard wall system was selected to illustrate the variance between the materials. The standard wall has wood studs, sixteen inches on center, with a single sheet of 5/8 inch drywall on either side. Materials that have higher sound absorption are preferred.

3.2.1.3 Infiltration

Infiltration effectively short circuits the building envelope by allowing air and moisture to enter and exit the building, thereby carrying with it the energy spent for conditioning. Insulation materials vary greatly in their ability to prevent infiltration. For the purposes of this research, air infiltration which bypasses the insulating material through gaps located between the insulating material and the structural members will be the only type of infiltration under consideration. Test methods for determining air leakage include ASTM E799. However, very little research has been conducted on the comparison between insulating materials. Therefore, certain assumptions regarding the various types of materials must be made. Materials which must be cut-to-fit will not fill the wall cavity as well as blown-in or foamed-in-place alternatives. The decision-maker prefers materials which completely fill cavities, thus preventing air from flowing around the insulation.

3.2.1.4 Fire Resistance

The safety of the building occupants is an obvious concern for the decision-maker and fire represents a risk in any facility. This risk is mitigated by building codes which require fire notification and suppression systems. However, building materials have an impact on how hot a fire will burn and how fast it will spread. Some insulating materials are naturally resistant to fire while others must be treated to improve fire resistance. Still others tend to burn readily once ignited and must be covered with drywall to meet code requirements. In addition to the actual fire, smoke can be harmful if not deadly. Therefore, both burn and smoke characteristics of insulating materials are important in the event of a fire. Clearly, the decision-maker prefers materials with greater ability to resist fire and the release of smoke.

3.2.1.4.1 Burn Characteristic. The burn characteristics of building materials are measured by the ASTM E84. The method measures the spread of a flame on the surface of the material as compared to that of select grade red oak which has a flame spread rating of 100 and a smoke development rating of 100. The test is conducted by supporting a specimen above a flame so that the speed of the flame can be observed from below. The units of measure are in inch pounds. The decision-maker prefers materials with lower flame spread ratings.

3.2.1.4.2 Smoke Development. In addition to flame spread, smoke development is also measured by ASTM E84. The density of the smoke is determined by the percent of light transmittance through the smoke that is generated during the flame spread test. The smoke development rating is an index developed for this test. The decision-maker prefers materials which generate less smoke.

3.2.2 Environmental Impact

The next second-tier objective encompasses the life-cycle environmental impact of the alternatives. As discussed in Chapter Two, life-cycle analysis quantifies the environmental impact of the raw materials and manufacturing processes. However, some categories of a typical life-cycle study are not independent of each other. For example, global warming potential and criteria air pollutants are typically included in life-cycle studies. Criteria air pollutants can include gases which are considered GHGs. Therefore, the decision-maker selected relevant life-cycle information which was independent from other information contained in the study. The decision-maker chose GHG emissions generated during production, the percent of recycled material included in the product, and the percent of hazardous material required for production.

3.2.2.1 Greenhouse Gas Emissions

The issue of global climate change is beyond the scope of this research; however, Executive Order 13423 requires that all federal agencies reduce energy consumption by 3 percent per year for the next ten years in order to reduce GHG emissions. Energy consumption directly translates into GHG emissions because approximately 85% of the energy generated in the United States is from burning fossil fuels. Even though the energy consumption from the production process would not be associated to a federal agency, Executive Order 13423 indicates the significance of GHGs.

3.2.2.2 Recycled Content

Sustainability requires that materials which are no longer useful in their current form be collected and utilized as raw materials for other products. Several insulation alternatives, including glass, paper, and cotton cloth, are made from raw materials that have been recycled. Removing material from waste streams not only reduces the burden on landfills but also reduces the impact on the environment from obtaining new materials. Furthermore, recycled materials are usually less expensive to process than new raw materials. The decision-maker prefers alternatives with recycled content.

3.2.2.3 Hazardous Materials

The amount of hazardous materials required for the manufacturing process can have a negative impact on the environment. This objective takes into account the raw, hazardous materials required for the manufacturing process. Non-hazardous materials are inert and do not pose a risk to the environment. This value considers the raw materials only and not the finished product itself. The decision-maker prefers non-hazardous materials.

3.2.3 Impact on Human Health

Depending on the type of material, the manufacturing and installation of insulation can have negative impact on the health of those who are subjected to long-term exposure. Additionally, the type of insulation material in a building can have a dramatic affect on the health of the building's occupants because moisture can accumulate within the wall cavity and insulation can provide the surface area for mold spores to grow.

3.2.3.1 Mold

The building envelope provides occupants protection from airborne insulation particles; however, the occupants are not without risk of health problems. Mold is a major contributor to poor indoor air quality and can cause a variety of breathing problems for building occupants ranging from minor to severe depending on the sensitivity of the occupants. According to the EPA, mold growth is best controlled by controlling moisture (EPA, 2007). The decision-maker prefers materials which will not accumulate moisture.

3.2.3.2 Exposure

Some insulating products are not durable and can breakdown during handling. Additionally, the light fibers that serve to reduce thermal conductivity can become airborne during handling from manufacturing and installation processes. As a result, workers associated with manufacturing and installation have an increased risk to adverse health effects due to long term exposure to air with high concentrations of particulates. The building envelope serves to protect the material from being disturbed and therefore the building occupants are not exposed after the building is complete.

3.3 Evaluation Measures

Once the objectives have been identified and arranged in a hierarchy, a method of measurement must be determined for all objectives in the lowest tier. The evaluation measures provide a means to assess how well an alternative meets the objective. The decision-maker has determined appropriate methods and units to measure the lowest tier objectives, a summary of which is provided in Table 3.1; additionally, the hierarchy with

measures is presented in Figure 3.2. The rationale for each of the evaluation measures is explained in the remainder of this section.

Table 3.1. Evaluation measures

Objective	Unit of Measure	Scale Type	Measure Type	Lower Bound	Upper Bound
Effective Thermal Performance	Effective R-Value	Natural ^a Direct ^b	Continuous	87.3%	98.2%
Sound Attenuation	Sound Transmission Class (STC)	Natural Direct	Discrete	0 dB	56 dB
Burn Characteristic	Flame Spread	Natural Direct	Discrete	0	75
Smoke Development	Smoke Generation	Natural Direct	Discrete	0	450
Infiltration	Resistance to Infiltration	Constructed ^c Direct	Discrete/ Categorical	Poor	Excellent
Hazardous Materials	Percent of Hazardous Material	Natural Direct	Continuous	0%	100%
GHG Emissions	Embodied Energy	Natural Proxy ^d	Continuous	0.5 MJ/M ² /RUnit	34.4 MJ/M ² /RUnit
Recycled Content	Percent of Recycled Material	Natural Direct	Continuous	0%	100%
Mold	Permeability	Natural Proxy	Discrete/ Binary	Non- Permeable	Permeable
Exposure	MSDS Health Rating	Natural Direct	Discrete/ Categorical	0	4

^a A natural scale is a common measure and generally accepted by everyone.

^b A direct scale is a direct measure of the degree of attainment.

^c A constructed scale is developed for lack of a natural measure.

^d A proxy scale indicates the degree of attainment and is not a direct measure.

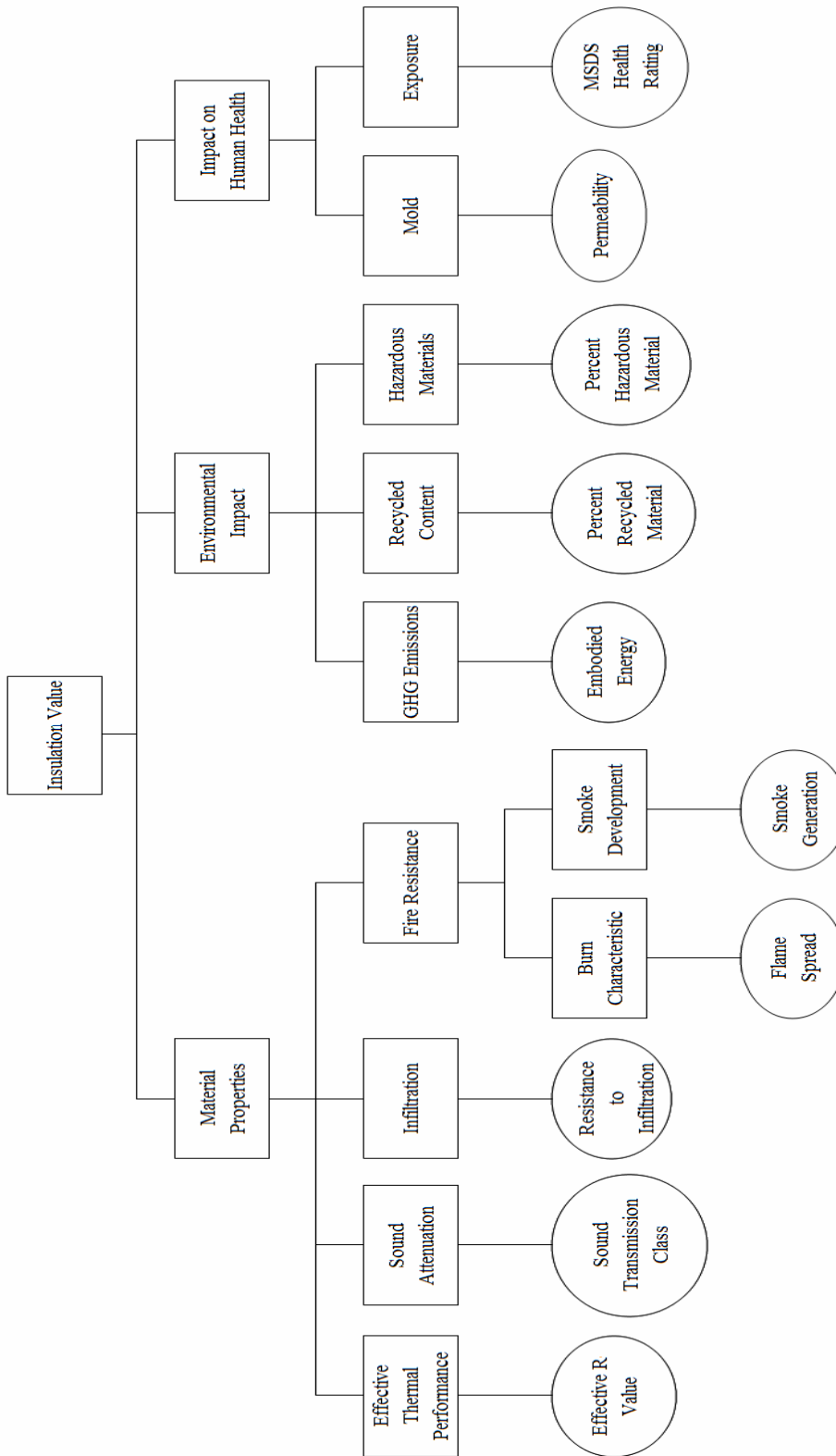

Figure 3.2. Objective Hierarchy with Evaluation Measures

3.3.1 Thermal Performance

The effective R-value is the natural, direct measurement which was developed to evaluate the variability of a material's thermal conductivity with respect to the temperature gradient across the building envelope. Therefore, effective R-value is represented as a percentage of the ASTM rated R-value with respect to temperature gradient and was calculated using Equation 3.1,

$$R_{effective} = \frac{R_{observed}}{R_{ASTM}}, \text{ at } C_x \quad (3.1)$$

where $R_{effective}$ is the effective R-Value, C_x is the climate of zone x , $R_{observed}$ is the observed R-Value (hr·ft²·°F/BTU), and R_{ASTM} is the ASTM measured R-Value (hr·ft²·°F/BTU). The upper and lower bounds were derived from studies conducted on the effect temperature gradient has on thermal conductivity. The lower bound is 87.3% and the upper bound is 98.2%. In addition to Equation 3.1, $R_{effective}$ values were calculated using average monthly temperature data for each location. The monthly $R_{effective}$ values of each location were then averaged. The details of these calculations are provided in Chapter 4.

3.3.2 Sound Attenuation

The evaluation measure selected for sound attenuation is the Sound Transmission Class (STC) which is a natural, direct measure. STC is a standard measure of airborne sound transmission and is determined by ASTM test E413-04. STC rating is determined from sound attenuation levels from 125 Hertz to 4000 Hertz. Test results are integers, with the lowest rating of 0 representing no sound attenuation. The North American

Insulation Manufactures Association (NAIMA) considers a level of 56 or greater to be excellent sound attenuation and was chosen as the upper bound (NAIMA, 2004).

3.3.3 Infiltration

Resistance to infiltration is the constructed, direct measure for infiltration. Resistance to infiltration is a function of the physical properties of the material and the method of application. Loose-fill and batt products do not seal against structural members well. However, facing increases resistance to infiltration. Sprayed-in products, such as cellulose, perform well because of adhesives within the spray bond the material together and help to seal the product to structural members. The best performing products are foamed-in-place because the product fills cracks and gaps within the cavity. The measure is categorical and the scores are poor, fair, good, very good, and excellent. The lower bound is poor and the upper bound is excellent.

3.3.4 Burn Characteristic

The evaluation measure for burn characteristic is the natural, direct scale called flame spread which is the rating obtained from the standard test ASTM E 84-07. Flame spread quantifies the speed at which a material will burn when in contact with fire. Flame spread values are integers and range from 0 to 200. However, the range used in this research was limited to that of the alternatives. The lower bound is 0 and represents no flame spread. The upper bound is 75 and represents the fastest flame spread of the alternatives.

3.3.5 Smoke Development

Smoke generation is the natural, direct scale for the evaluation measure Smoke Development. In addition to flame spread, ASTM E 84-07 includes a standardized test to measure the amount of smoke produced from a particular material. Values are integers and range from 0 to 450 with 450 having the highest level of smoke produced for all alternatives. The lower bound of this evaluation measure is 0 and the upper bound is 450.

3.3.6 Greenhouse Gas Emission

Embodied energy input is the natural, proxy scale evaluation measure for GHG emission. Embodied energy is a summation of GHG emissions resulting from manufacturing the product. However, the units in published literature are million joules per meter squared for one inch of thickness. This research assumes that the insulation selected will be based on R-value specified and not thickness. The thickness for R-31 will depend on the type of material. Therefore, the data, which will be presented in Chapter 4, has been normalized to account for the differences in thermal conductivity and was calculated using Equation 3.2,

$$EE_{normalized} = \frac{EE}{(R / inch)} \quad (3.2)$$

where $EE_{normalized}$ is the normalized embodied energy ($MJ/m^2/R$), EE is the embodied energy per inch of thickness ($MJ/m^2/inch$), and R is the thermal resistance ($hr \cdot ft^2 \cdot ^\circ F / BTU$). Proxy measures are the least desirable measures because there can be inaccuracies from using a scale that is not a direct measure. However, embodied energy is the standard method for measuring the combined effect of GHG emissions. Therefore,

embodied energy is an appropriate scale for measuring GHG emissions. This scale was determined from the data which was collected and has a lower bound of 0.5 MJ/m²/R and an upper bound of 34.4 MJ/m²/R.

3.3.7 Recycled Content

The percent of recycled material is the natural, direct scale for the evaluation measure of recycled content. The percentage of recycled material is based on gross weight of each alternative. The volume of recycled content is not as appropriate as gross weight because materials which are taken to a landfill are typically compacted. This scale was derived from the data which was collected for the alternatives and has a lower bound of 0 percent and an upper bound of 100 percent.

3.3.8 Hazardous Materials

Hazardous material content is the natural, direct scale used to evaluate hazardous materials. The percentage of hazardous material was derived from the raw materials required for the manufacturing process of each alternative. A raw material was considered hazardous if the waste for that material is regulated as hazardous by the EPA. The lower bound is 0 percent and the upper bound is 100 percent.

3.3.9 Mold

Permeability is the natural, proxy scale used to measure adverse health effects caused by mold. Again, proxy measures are not desired; however, as noted in section 3.2.1, mold will grow on damp indoor surfaces when there is a food source and the best

way to control mold growth is by controlling moisture. One of the primary purposes of the building envelope is to control moisture. However, liquid water and water vapor can penetrate the building envelope and saturate permeable materials. ASTM E-96 is a standard test which measures the permeability of materials; however, manufacturers do not test the permeability of all insulation materials. The decision-maker noted that the materials which do not have a permeability rating are those which are fibrous or porous and materials which have a permeability rating are those which have an extremely low permeability and will not absorb significant amount of water. Furthermore, the decision-maker feels that the differences between materials which have a permeability rating are negligible. Therefore, the decision-maker feels that permeability is a binary measure. The lower bound is permeable and represents materials which do not have a permeability rating. The upper bound is non-permeable and represents materials which have a permeability rating. Non-permeable materials are preferred.

3.3.10 Exposure

Material Safety Data Sheet (MSDS) health rating is the natural, direct scale used to measure the degree of attainment of effect from exposure. The measure identifies only the hazards associated with handling the end product and does not attempt to quantify hazards associated with the raw materials. MSDS health ratings are integers which range from 0 to 4. A rating of 0 is the lower bound and represents no health risks. A rating of 1 indicates a slight health hazard. A rating of 2 is a moderate health hazard. A rating of 3 indicates serious health hazards and a rating of 4 represents an extreme health hazard.

3.4 Creating Value Functions

Single Dimensional Value Functions (SDVFs) enable the decision-maker to assign various levels of value or “goodness” across the range of the measure (Kirkwood, 1997). The decision-maker was asked to consider the range of each evaluation measure and determine how much value to place on the various increments within the range. This section illustrates the SDVFs for this decision model as determined by the decision-maker. Only representative SDVFs are shown; the other value functions are presented in Appendix B. A Microsoft Excel add-on called Hierarchy Builder was used to construct the model.

3.4.1 Effective R-Value Value Function

Effective R-value is a measure of the variance in thermal performance as a result of climate and is represented as a percentage of the ASTM R-value. This value function is continuous because there are an infinite number of possibilities. The function is monotonically increasing because a higher effective R-value represents less degradation in thermal performance which is preferred. The decision-maker feels that the function is linear; therefore, the effective R-value value function is shown in Figure 3.3.

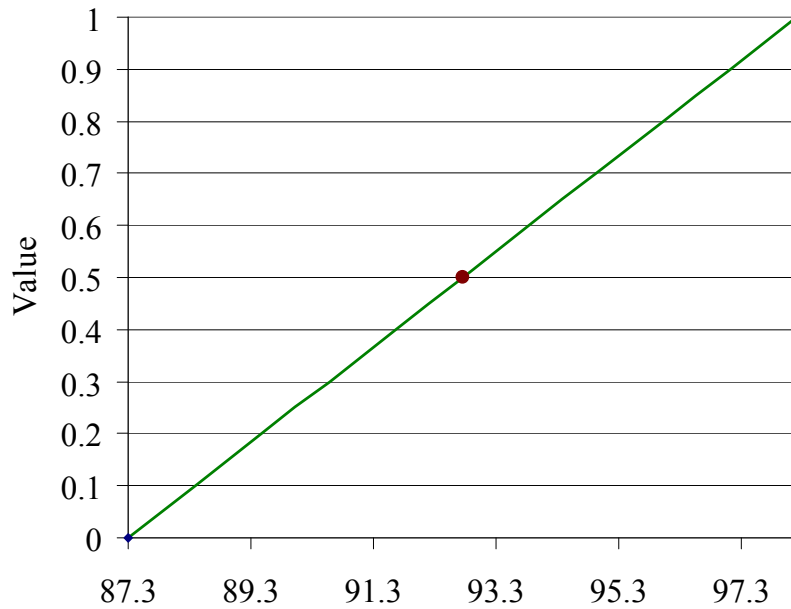

Figure 3.3. Effective R-value SDVF

3.4.2 Sound Transmission Class Value Function

Sound Transmission Class represents a material's ability to absorb sound and is calculated using ASTM test E413-04. Although the graph is shown as continuous, the function is actually discrete because the value of STC can only be an integer.

Additionally, the function is monotonically increasing because a higher STC rating is preferred. However, the decision-maker feels there is a decreasing rate of return, which is called marginally decreasing. This is because there is only minimal benefit after the desired level of sound attenuation is achieved. Therefore, incremental increases in STC above the minimum desired amount correspond with smaller increases in value. The resulting STC value function is shown in Figure 3.4.

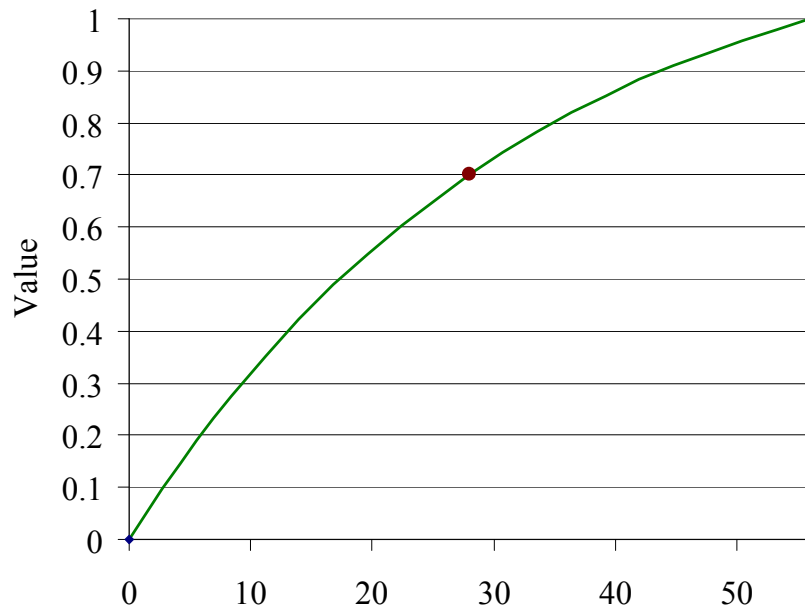

Figure 3.4. Sound Transmission Class SDVF

3.4.3 Resistance to Infiltration Value Function

The value function for resistance to infiltration is the constructed, direct scale to measure the existence of bypass infiltration. Air bypass is minimized when the entire cavity is filled with insulation. The scale is categorical and monotonically increasing. The decision-maker feels that the value function for resistance to infiltration is linear and is shown in Figure 3.5.

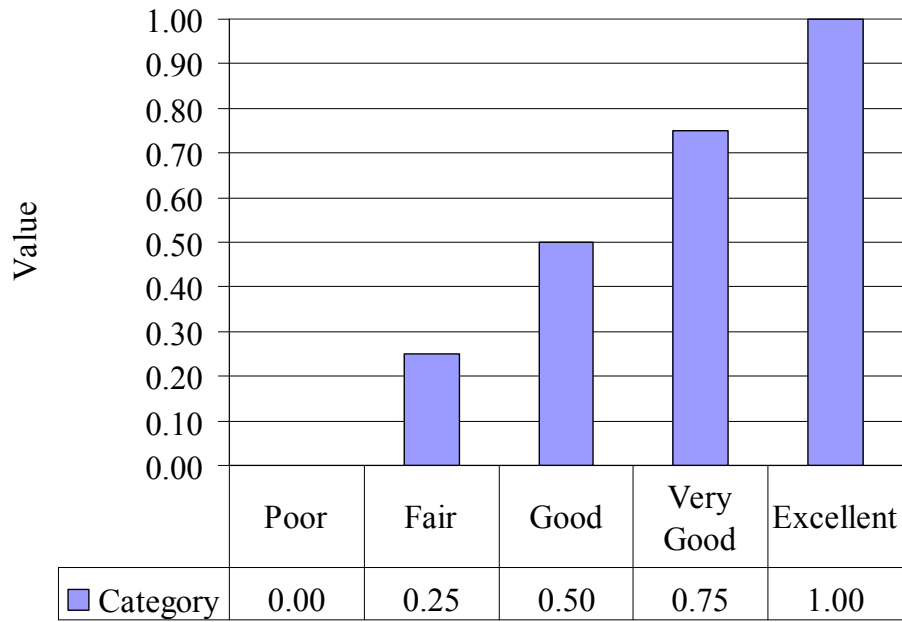

Figure 3.5. Resistance to Infiltration SDVF

3.4.4 Flame Spread Value Function

The value function for flame spread is discrete and monotonically decreasing because the values obtained from ASTM E 84-07 are integers and a higher score represents faster flame spread. The decision-maker feels that the relationship between value and flame spread is linear. The SDVF for flame spread is shown in Figure 3.6.

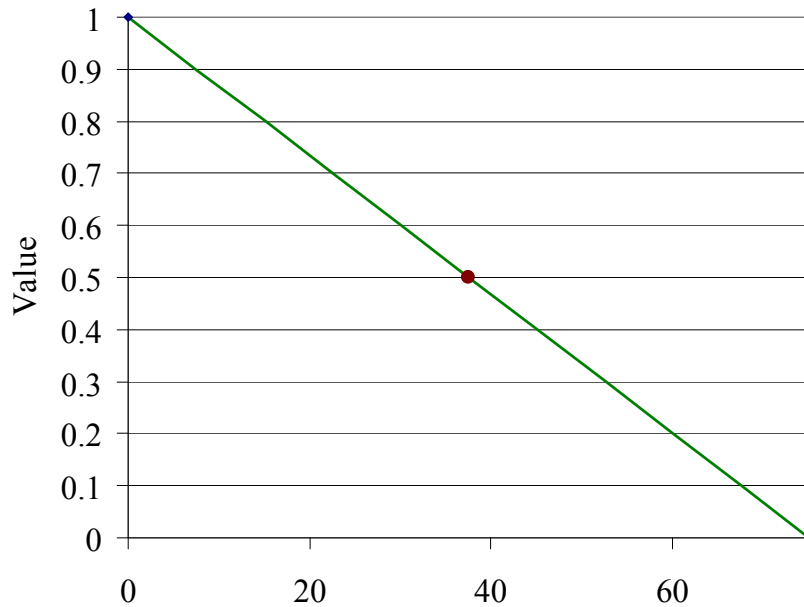

Figure 3.6. Flame Spread SDVF

3.5 Weighting the Hierarchy

The next step in Shoviak's (2001) ten-step process is weighting the hierarchy. Three climates were considered in this research; therefore, three weighting systems were developed. The measures were listed from most important to least important. Using the least important value as a reference, the decision-maker was then asked to determine the relative importance of the remaining measures and express it as a multiple of the least important measure. The sum for each measure was divided by the total of all multiples to determine the global weights. Although this process was completed for each of the three climate zones, the decision-maker's weights are specific to the AFIT academic facility. The multiples and resulting global weights of climate zone 3 are provided in Table 3.2 and Figure 3.7. Similar data for climate zones 1 and 5 can be found in Appendix C.

Table 3.2. Weights for Climate Zone 3 (Dayton Ohio)

Lowest Tier Objective	Multiple	Weight
Embodied Energy	1	0.047619048
Percent Recycled Material	1	0.047619048
MSDS Health Rating	1	0.047619048
Percent Hazardous Material	1	0.047619048
STC Rating	1	0.047619048
Permeability	2	0.095238095
Flame Spread	3	0.142857143
Smoke Development	3	0.142857143
Resistance to Infiltration	4	0.19047619
Effective R-Value	4	0.19047619
	21	1

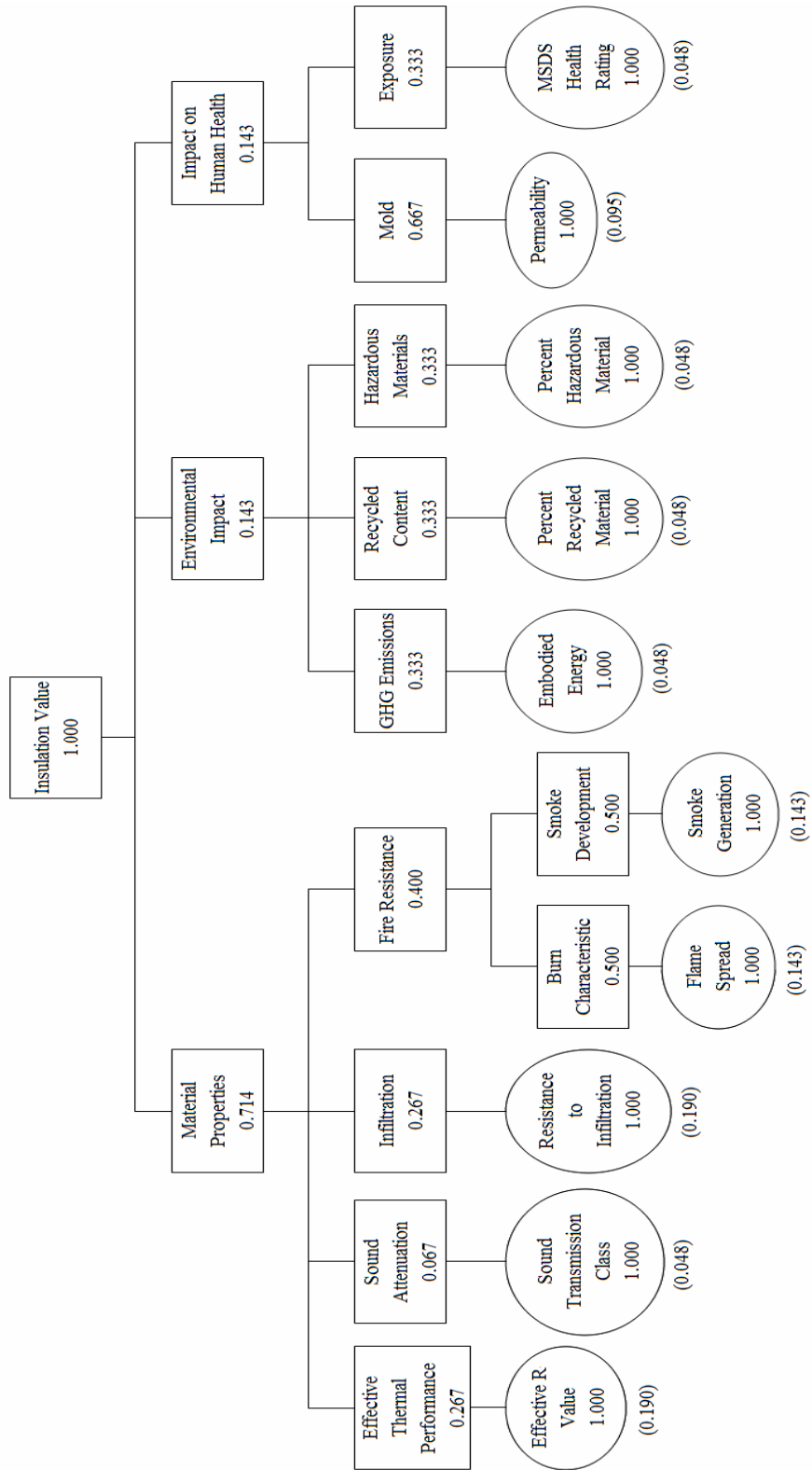

Figure 3.7. Hierarchy with Local Weights (Global Weights)

3.6 Alternative Identification

The alternatives selected for this research include several insulation products which are currently on the market. A list of the alternatives is provided in Table 3.3. The data and the scores for each alternative will be presented in Chapter 4.

Table 3.3. List of Alternatives

Alternative	Facing	Brand	Type
Fiberglass Batt (.82 lb/ft ³)	Unfaced	Owens Corning	Thermal Batt
Fiberglass Batt (.82 lb/ft ³)	Foil	Owens Corning	Thermal Batt
Fiberglass Batt (.82 lb/ft ³)	Kraft	Owens Corning	Thermal Batt
Fiberglass Blown In (1.68 lb/ft ³)	Unfaced	Owens Corning	ProPink
Fiberglass Rigid Board (1.68 lb/ft ³)	Unfaced	Owens Corning	701 Insulation
Fiberglass Rigid Board (3.49 lb/ft ³)	Unfaced	Owens Corning	703 Board
Fiberglass Loose-Fill (.82 lb/ft ³)	Unfaced	Owens Corning	ThermaGlas
Cellulose Spray In (wood wool)	Unfaced	Nu Wool	N/A
Rock Wool (4.44 lb/ft ³)	Unfaced	Delta	CW4A
Rock Wool (8.45 lb/ft ³)	Unfaced	Delta	CW8A
Polyurethane Expand In-Place	Unfaced	Dow	Styrofoam
Polyurethane Expand In-Place	Unfaced	Tiger Foam	2 part spray
Polystyrene (1.07 lb/ft ³)	Unfaced	Owens Corning	Foamular 250
Polystyrene (2.43 lb/ft ³)	Unfaced	Owens Corning	Foamular 250
Polystyrene (2.4lb/ft ³)	Unfaced	Falcon Foam	Polystyrene
Cotton Batt (1.29 lb/ft ³)	Unfaced	UltraTouch	N/A

Chapter 4 – Results and Analysis

This chapter discusses the analysis portion of the decision model as described in steps seven, eight, and nine of Shoviak's 10-step VFT process (Shoviak, 2001). Step seven is the process of scoring the measures in the hierarchy for each alternative. Step eight, deterministic analysis, ranks the alternatives according to the decision model. Hierarchy Builder, an add-on for Microsoft Excel, was used in this research to generate the decision model, score the measures, and calculate alternative rankings. Step nine includes a sensitivity analysis which allows the decision-maker to understand the impact of the weights on the measures. Three decision models were built for this research in order to determine if climate is a significant factor in the decision problem. However, sensitivity analysis was only conducted on climate zone 3 because the AFIT academic facility is actually located within climate zone 3.

4.1 Alternative Scoring

Alternative scoring requires that the data for each measure and alternative is inputted into the model. The data associated with the measures for each alternative were collected from a variety of sources including manufactures' specifications, Material Safety Data Sheet (SDS), independent research, and federal government agencies. It should be noted that product data from manufacturers can differ from independent lab tests; therefore, the accuracy of this data was scrutinized to help ensure the accuracy of the model. The data for the measures that was collected for this research is shown in Table 4.1. Effective R-values for climate zones 1 and 5 are presented in Appendix C.

Table 4.1. Matrix of hierarchy measure scores (Dayton, Ohio)

	Type of Facing ^a	Effective R-Value ^b	STC (3.5"x 16" SOC 1/2" drywall) ^a	Resistance to Infiltration ^c	Flame Spread ^a	Smoke Generation ^a
Owens Corning Fiberglass Batt (.82 lb/ft ³)	Unfaced	90.4	39	Poor	25	50
Owens Corning Fiberglass Batt (.82 lb/ft ³)	Foil	90.4	39	Fair	75	150
Owens Corning Fiberglass Batt (.82 lb/ft ³)	Kraft	90.4	39	Fair	75	150
Owens Corning Fiberglass Blown In (1.68 lb/ft ³)	Unfaced	90.4	39	Poor	0	0
Owens Corning Fiberglass Rigid Board (1.68 lb/ft ³)	Unfaced	92.0	39	Good	20	20
Owens Corning Fiberglass Rigid Board (3.49 lb/ft ³)	Unfaced	92.0	39	Good	15	20
Owens Corning Fiberglass Loose-Fill (.82 lb/ft ³)	Unfaced	94.5	39	Poor	25	50
Nu Wool Cellulose Spraed-In (3.0 lb/ft ³)	Unfaced	93.6	41	Very Good	15	5
Delta Rock Wool (4.44 lb/ft ³)	Unfaced	92.7	38	Poor	0	0
Delta Rock Wool (8.45 lb/ft ³)	Unfaced	95.2	38	Poor	0	0
Dow Polyurethane Expanding Foam	Unfaced	91.2	39	Excellent	25	400
Tiger Foam Polyurethane Expanding Foam	Unfaced	91.2	39	Excellent	25	200
Owens Corning Polystyrene (1.07 lb/ft ³)	Unfaced	95.6	39	Excellent	5	175
Owens Corning Polystyrene (2.43 lb/ft ³)	Unfaced	94.8	39	Excellent	5	175
Falcon Faom Polystyrene (2.4 lb/ft ³)	Unfaced	94.8	39	Excellent	25	450
UltraTouch Cotton Batt	Unfaced	90.4 ^e	45	Fair ^e	5	35

^a Manufacturer's data

^b Calculated using Equation 3.1 and information presented by Budaiwi et. al., 2002

^c Al-Homoud, 2005

^d Harvey, 2007

^e Estimated

4.2 Deterministic Analysis

For this research, deterministic analysis consisted of inputting the data into the SDVFs created in Chapter 3 and then summing the normalized values for each measure with the additive value function. This was accomplished with the Hierarchy Builder add-on for Microsoft Excel, which also ranked the alternatives based on the overall score. A higher score represents an alternative which provides more value. A model was created for climate zones 1, 3, and 5. Models for climate zones 2 and 4 were not constructed because the difference in average monthly temperature was not thought to be significant.

4.2.1 Deterministic Analysis for Climate Zone 1 (Minot, North Dakota)

The results of the analysis for climate zone 1 are shown in Figure 4.1. Low density polystyrene is the highest ranked alternative in climate zone 1 with a value function sum of 0.729 followed by cellulose with a value function score of 0.687. All three fiberglass batt alternatives ranked poorly. The overall score is an important number; however, overall score does not provide the decision-maker or analyst insight into how the scores were attained. This information is obtained via the shaded bar, which graphically illustrates the amount of value each alternative received with respect to second tier objectives. In addition to providing insight, the shaded bar can reveal discrepancies in the model. Material properties dominates the highest ranking alternatives, while the lowest ranked alternatives scored poorly in material properties.

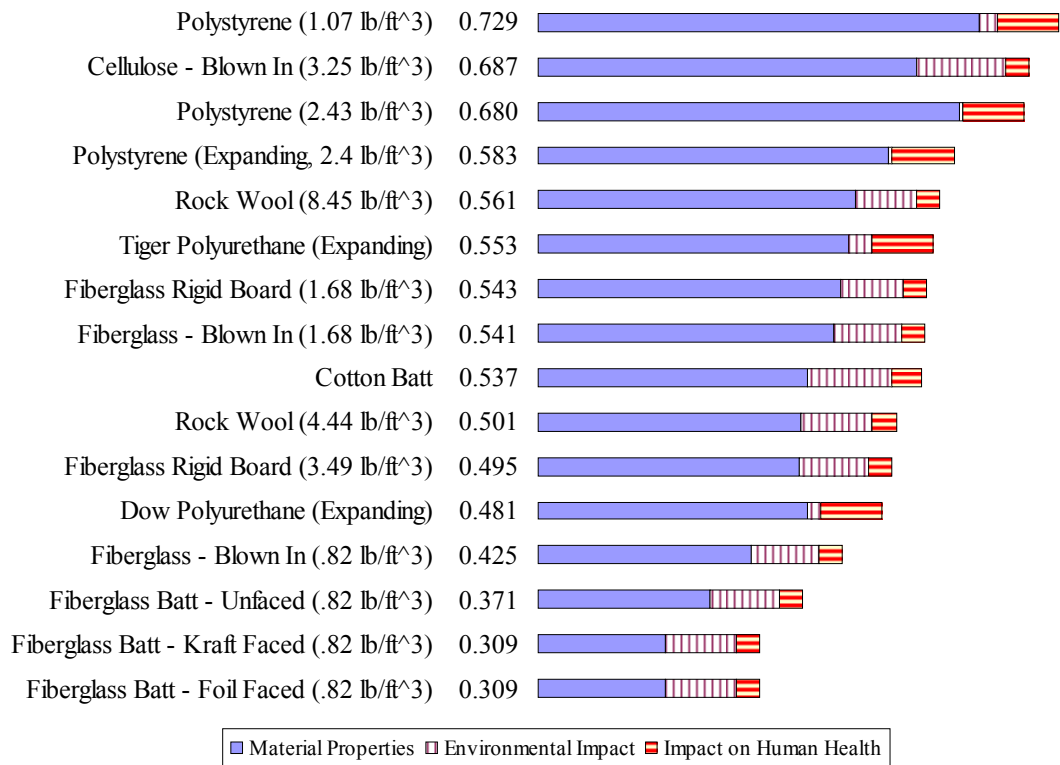

Figure 4.1. Climate Zone 1 Rankings – Second Tier (Minot, North Dakota)

Figure 4.2 provides the same overall results; however, the shaded bar now indicates the portion of the overall score that is attributed to the measures. The analyst can now quickly compare the alternatives according to the components of the additive value function. In comparison, low density polystyrene scored well in 8 of the 10 measures including effective R-value, resistance to infiltration, permeability, and flame spread. The lowest ranked alternatives scored poorly in several of the measures including the heavily weighted measures. Effective R-value is a significant source of value for the higher ranked alternatives. Resistance to infiltration, flame spread, and smoke generation are also important objectives. The variance of sound transmission class and impact to human health are minimal and neither has a significant impact on the rankings.

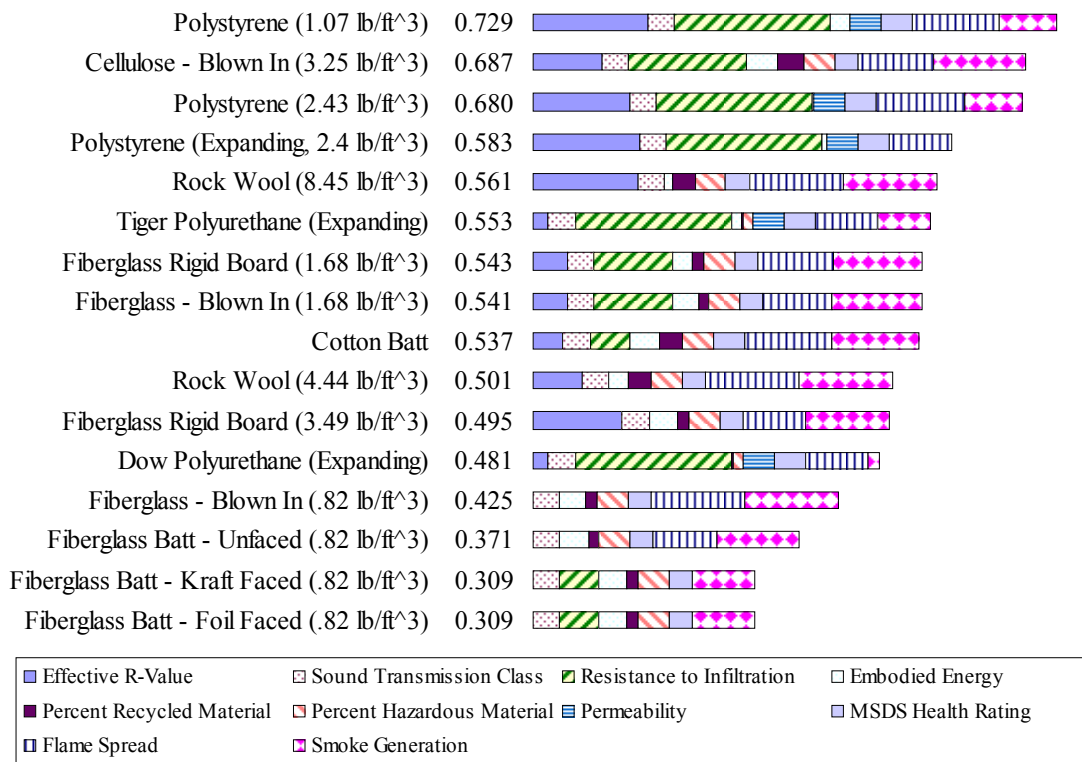

Figure 4.2. Climate Zone 1 Rankings – Measures (Minot, North Dakota)

4.2.2 Deterministic Analysis for Climate Zone 3 (Dayton, Ohio)

The weights were adjusted and the analysis was completed for Dayton, Ohio. The decision-maker placed less importance on effective R-value and increased the importance of mold. All other weights remained the same as the previous model. The results of the second tier analysis are shown in Figure 4.3. Low density polystyrene is the highest ranked alternative in this scenario with a value of 0.768. High density polystyrene moved up to second with a value score of 0.729. Fiberglass batt products continued to rank poorly. Material properties is extremely important to the overall ranking in this scenario and alternatives which score well in material properties typically ranked higher overall.

Conversely, alternatives which score poorly in material properties rank much lower. Environmental impact and human health are less significant because an alternative can score low in one or the other and still rank high.

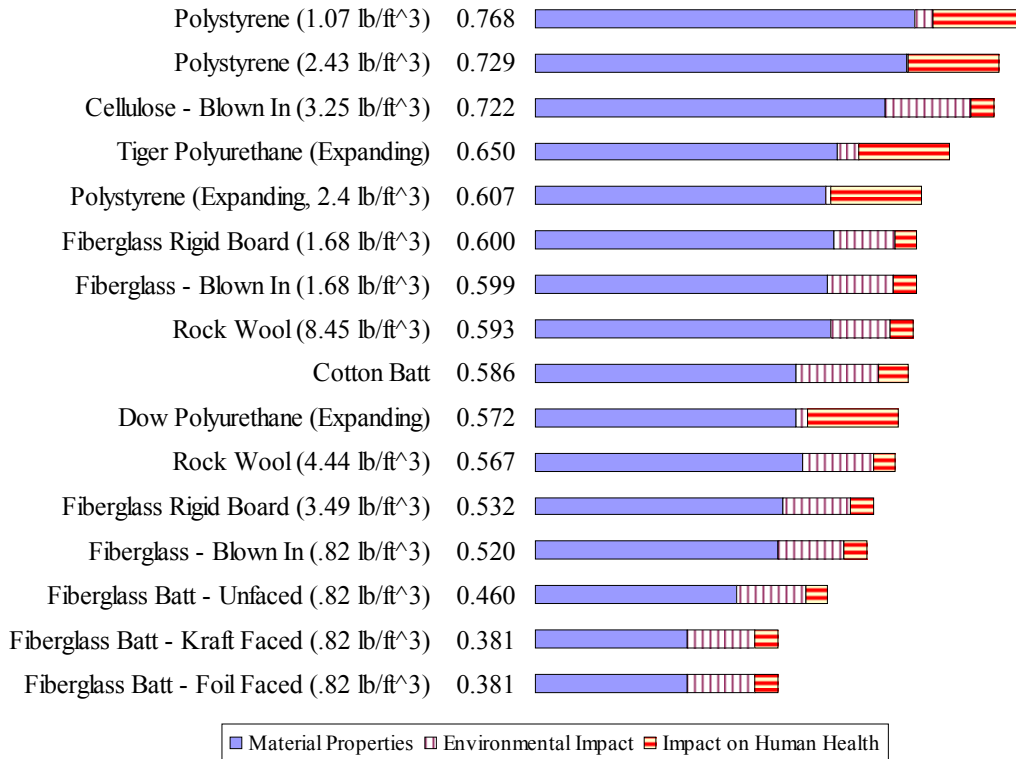

Figure 4.3. Climate Zone 3 Rankings – Second Tier (Dayton, Ohio)

The results of the analysis on the measures for climate zone 3 are shown in Figure 4.4. Low density polystyrene scored well in 8 out of 10 measures. The top three alternatives scored well in effective R-value, resistance to infiltration, flame spread, and smoke generation. While cellulose scored well in those areas, it fell to third because of the increased weight of permeability. The lowest ranked alternatives are fiberglass batt product, which scored poorly on several measures. All but two alternatives scored well

in flame spread which is the main reason for the poor rankings. There is minimal variance between the alternatives with respect to sound transmission class and MSDS rating; this indicates that this measure does not have a significant impact on the decision. Additionally, a low effective R-value score indicates that an alternative will likely rank in the middle or lower.

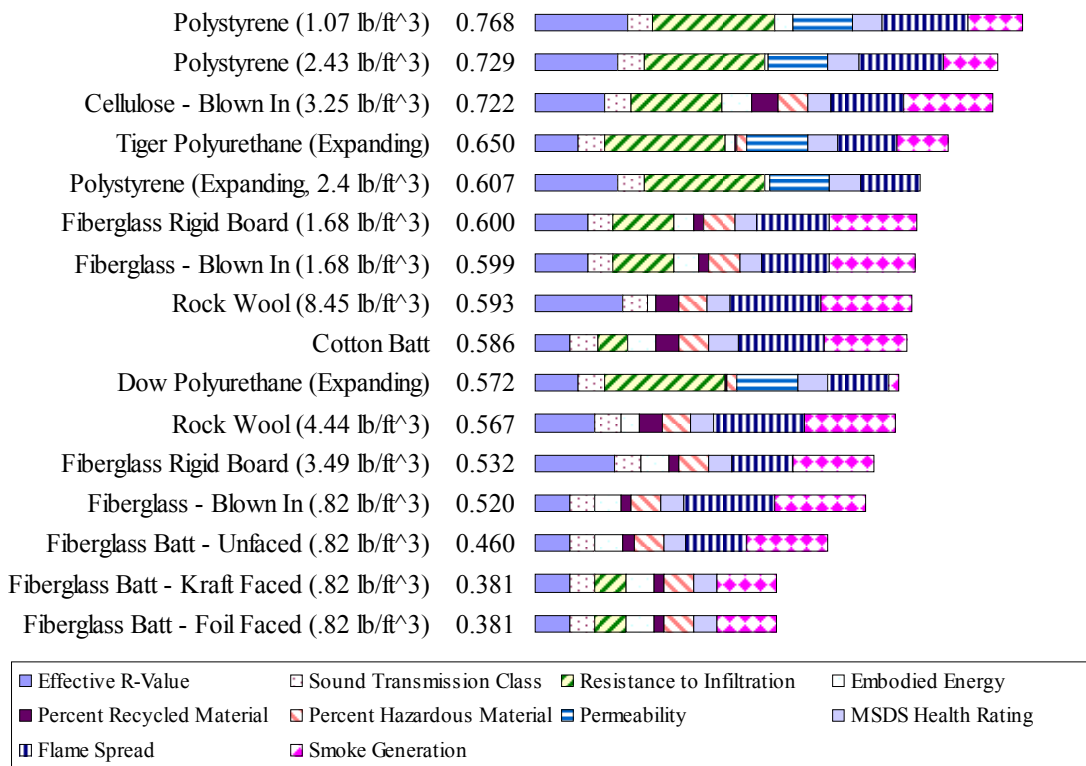

Figure 4.4. Climate Zone 3 Rankings – Measures (Dayton, Ohio)

4.2.3 Deterministic Analysis for Climate Zone 5 (Niceville, Florida)

The weights were again adjusted; this time for climate zone 5. The decision-maker placed additional importance on mold and reduced the importance of effective R-value. The results of the second tier analysis are shown in Figure 4.5. Once again,

polystyrene products rank first and second, while fiberglass batt products continue to rank the lowest. Climate zone five has similar characteristics as the previous models. Despite reducing the weight of effective R-value and increasing the weight of permeability, material properties is a significant factor in an alternative’s overall rank and environmental impact and impact on human health are tertiary factors.

Rankings based on Insulation Value

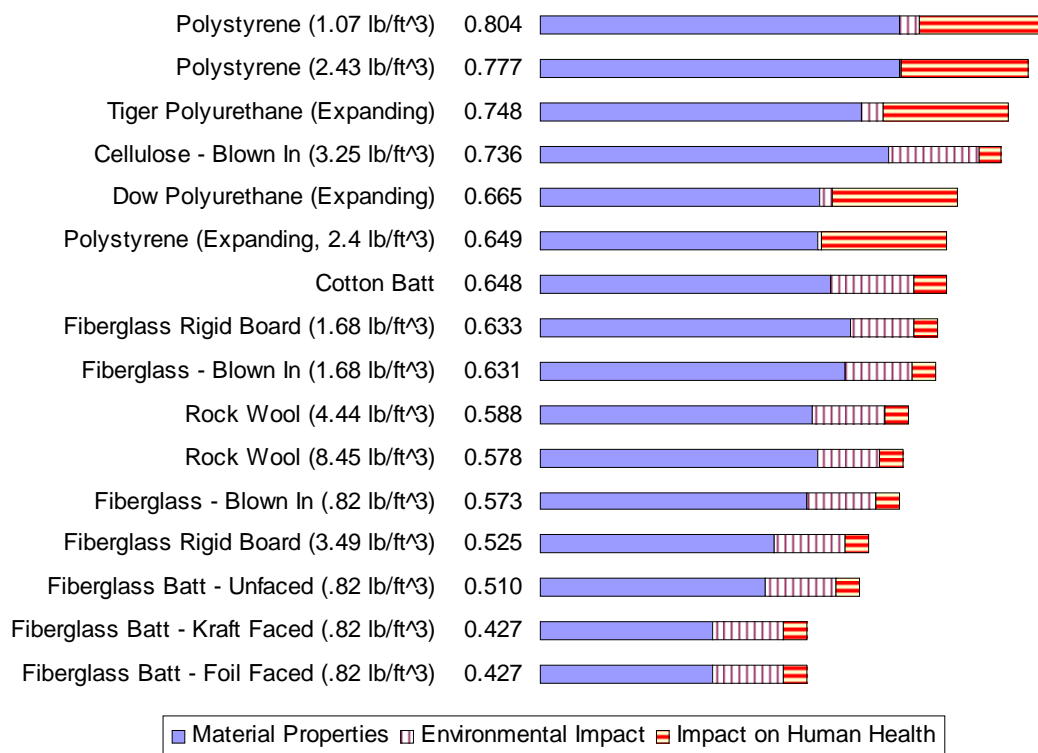

Figure 4.5. Climate Zone 5 Rankings – Second Tier (Niceville, Florida)

The results of the analysis on the measures are shown in Figure 4.6. Once again, low density polystyrene scored well on 8 of 10 measures, while the lowest ranked alternatives scored poorly on 8 of 10 measures. Resistance to infiltration appears to have

a significant impact on an alternative's overall score. Permeability is also significant because mold is of greater importance in this climate. Smoke generation is also significant because it is a heavily weighted measure. The lack of extreme temperatures in climate zone 5 resulted in minimal variance between alternatives with respect to effective R-value. Additionally, alternatives with low flame spread scores rank low.

Rankings based on Insulation Value

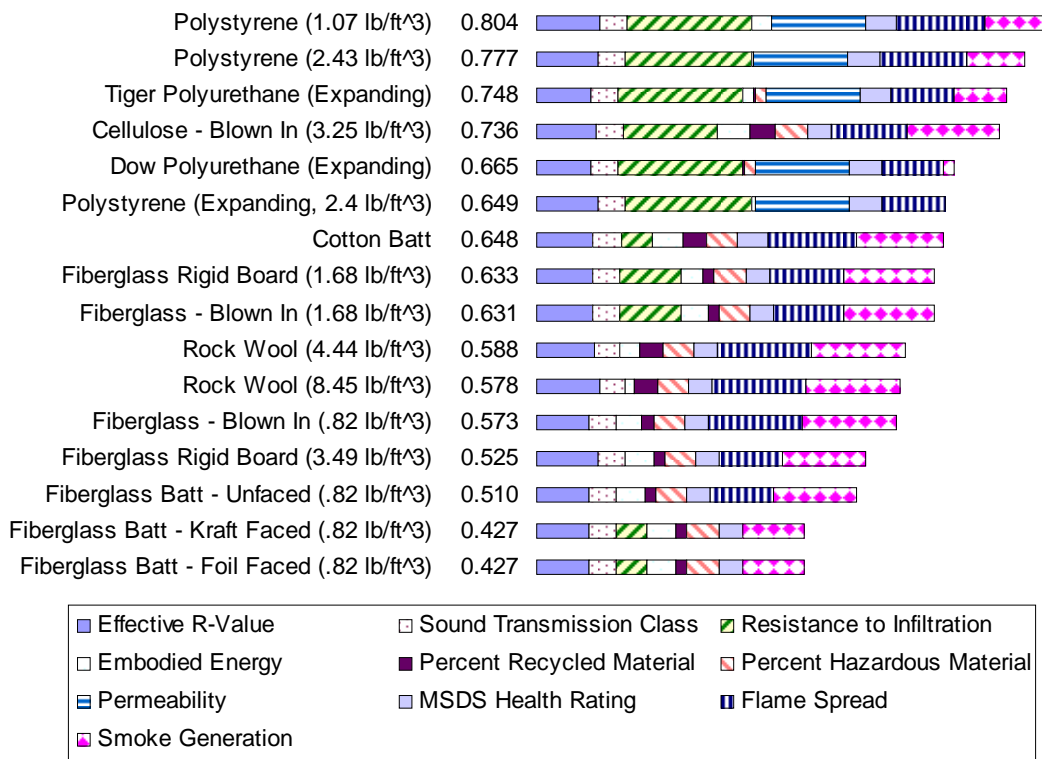

Figure 4.6. Climate Zone 5 Rankings – Measures (Niceville, Florida)

4.2.4. Deterministic Analysis Results

Material properties is the dominating objective in all climates. An alternative's resistance to infiltration score is also a significant factor in the overall score for all three

climate zones. Effective R-value has a significant impact on the value score in colder climates and permeability has a significant impact on the value score in warmer climates; however, there was no change in the top ranked alternative or lower ranked alternatives. Nonetheless, there were some rank changes among alternatives in the middle. MSDS health rating and STC have minimal impact on the variance between alternatives.

4.3 Sensitivity Analysis

Sensitivity analysis illustrates the impact on the ranking of alternatives as a result of changes in the weights (Kirkwood, 1997). A decision which is sensitive to changes in the weight of a measure should be scrutinized by the decision-maker to ensure that the decision will not change. Determining if the decision is sensitive to changes in weight is not defined by a clear set of rules. Many factors relating to the assumptions and constraints need to be considered. It is imperative that the analyst understand the sensitivity graphs in order to evaluate how changes in weight would impact the decision. In short, the vertical black line represents the current weight and the other lines represent an alternative. The line which intersects the vertical black line at the highest point is the top ranked alternative. A decision change exists at points where the top ranked alternative intersects with another line. The closer the intersection occurs to the current weight the more sensitive the decision is to the objective or measure. As such, only alternatives near these areas of interest are included in the analysis.

Conducting sensitivity analysis without the benefit of software is time consuming and can be subject to errors because of the numerous and tedious calculations. For this

research Hierarchy Builder was utilized to mitigate the risk of errors resulting from repetitious calculations.

4.3.1 Sensitivity of Second Tier Objectives for Climate Zone 3

Sensitivity analysis was conducted only on climate zone 3 because the AFIT academic facility is located within this climate. Therefore, additional analysis on other climates is not necessary for the decision-maker to determine the best alternative. Figure 4.7 shows how the overall value of each alternative would change as the weight for material properties changes from 0% to 100%. The current weight of material properties is 0.714 and is represented by the vertical black line. Low density polystyrene ranks high across a wide range of weights. In fact, the highest ranking alternative will not change unless the decision-maker reduces the weight of material properties to 0.092. Tiger polyurethane would then become the highest ranked alternative. Cellulose and high density polystyrene increase in overall score as the weight is increased but not enough to overtake low density polystyrene as the top ranked alternative. The decision-maker is not likely to reduce the weight of material properties to the degree necessary for a change in the decision. Therefore, the model is not considered sensitive to changes in material properties.

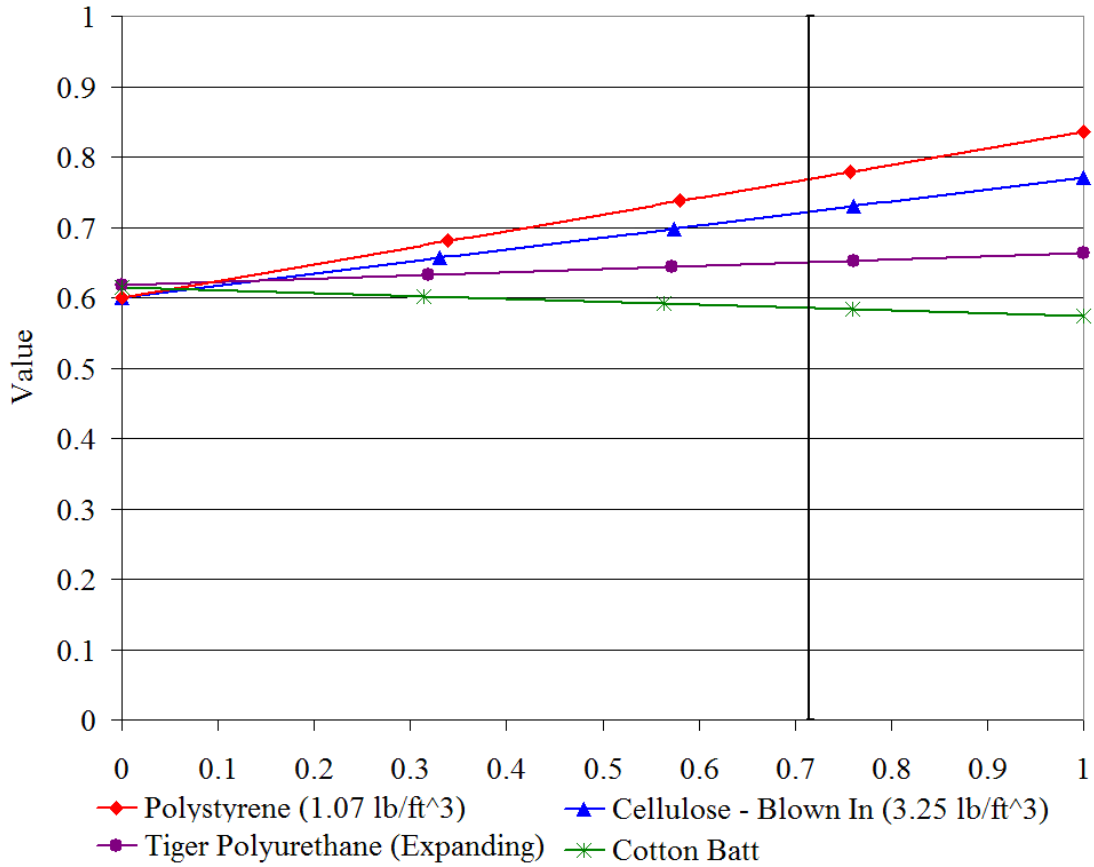

Figure 4.7. Sensitivity of Material Properties (Climate Zone 3)

Figure 4.8 illustrates how the overall rankings are affected by changes in the weight of environmental impact. The current weight of environmental impact is 0.143. Low density polystyrene does not score well in environmental impact because the slope of the line is negative. This is evident because as the weight is increased the overall value is reduced. However, cellulose scores well on this objective because the slope of the line is positive. In fact, cellulose would be the top ranked alternative if the decision-maker increased the weight of environmental impact to approximately 0.1932. The decision-maker would have to increase the weight by 35% for the decision to change.

Further analysis on measures within environmental impact will provide additional insight as to the sensitivity of the decision with respect to this objective.

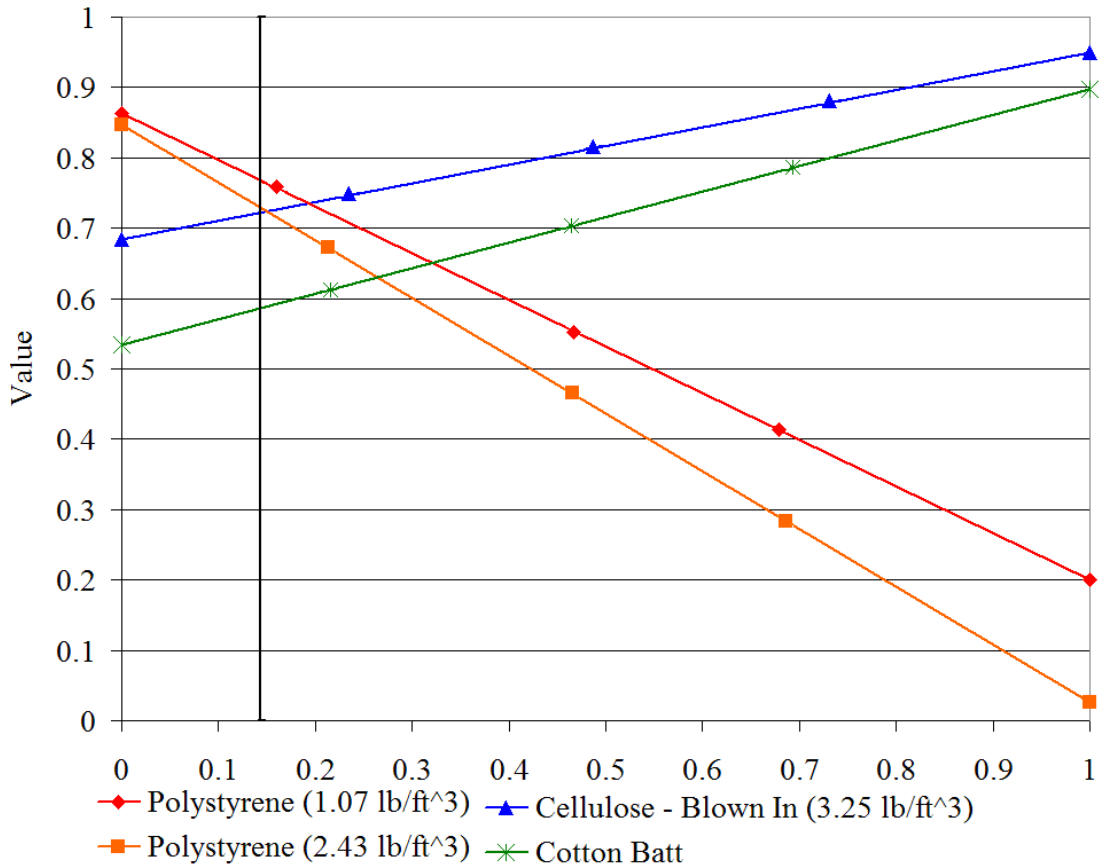

Figure 4.8. Sensitivity of Environmental Impact (Climate Zone 3)

Figure 4.9 illustrates how the overall rankings are affected by changes in the weight of impact to human health. The current weight of impact to human health is 0.143. Cellulose would become the highest ranked alternative if the decision-maker reduced the weight of this second tier objective to 0.820. Additional analysis needs to be conducted on the measures within impact to human health in order to determine if the decision is sensitive to the measures. The positive slope of polystyrene’s line indicates

that the alternative will gain value as the weight is increased. Conversely, cellulose has a negative slope. Three alternatives would score a maximum value if the weight of impact to human health was changed to 1.00. This means that the alternatives attained the upper bound on the measures within this objective.

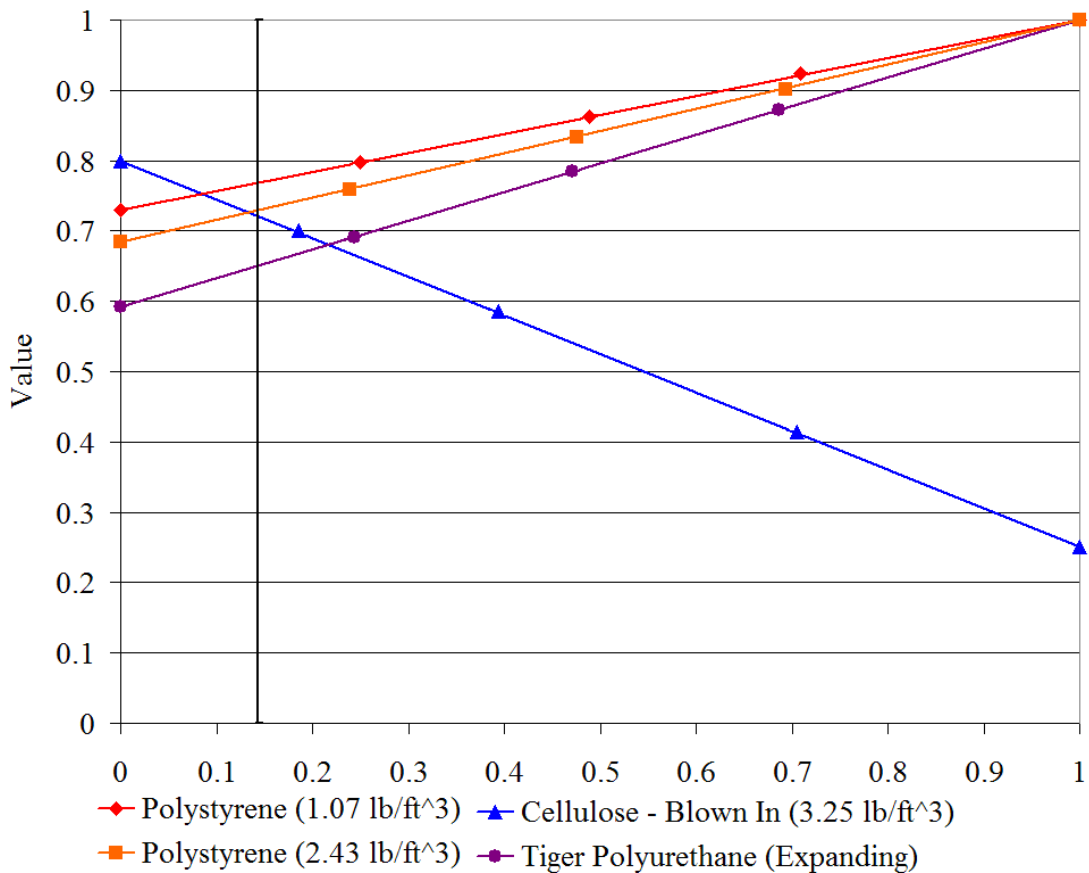

Figure 4.9. Sensitivity of Impact to Human Health (Climate Zone 3)

4.3.2 Sensitivity of Measures for Climate Zone 3

The following section includes the sensitivity analysis of measures which may be sensitive to changes in weight and include smoke generation, percent recycled content, hazardous waste content, and permeability. The sensitivity analysis for the remaining

measures is presented in Appendix B. The current weight of smoke generation is 0.143 and would need to increase to 0.2375 in order to change the decision from low density polystyrene to cellulose. The differential represents a change of 66 percent. This measure is already heavily weighted as compared to other measures. Based on these two factors, it can be concluded that the decision is not significantly sensitive to smoke generation.

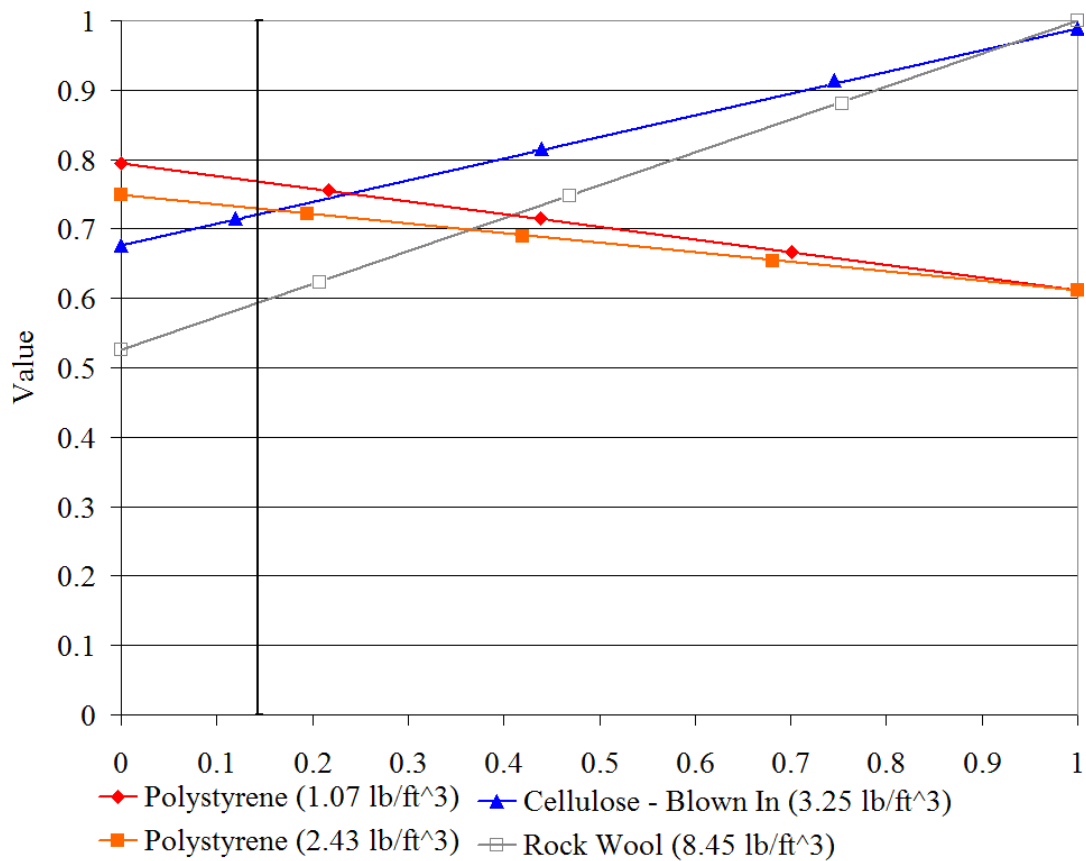

Figure 4.10. Sensitivity of Smoke Generation (Climate Zone 3)

The current weight of percent recycled material is 0.048. Cellulose would overtake low density polystyrene as the highest ranked alternative if the weight was increased to 0.0973. Measures that are tertiary concerns for the decision-maker have comparable weights to percent recycled content. Measures which have similar weight to that needed to change the decision are of greater importance to the decision-maker. Therefore, a conclusion can be made that the sensitivity is not significant.

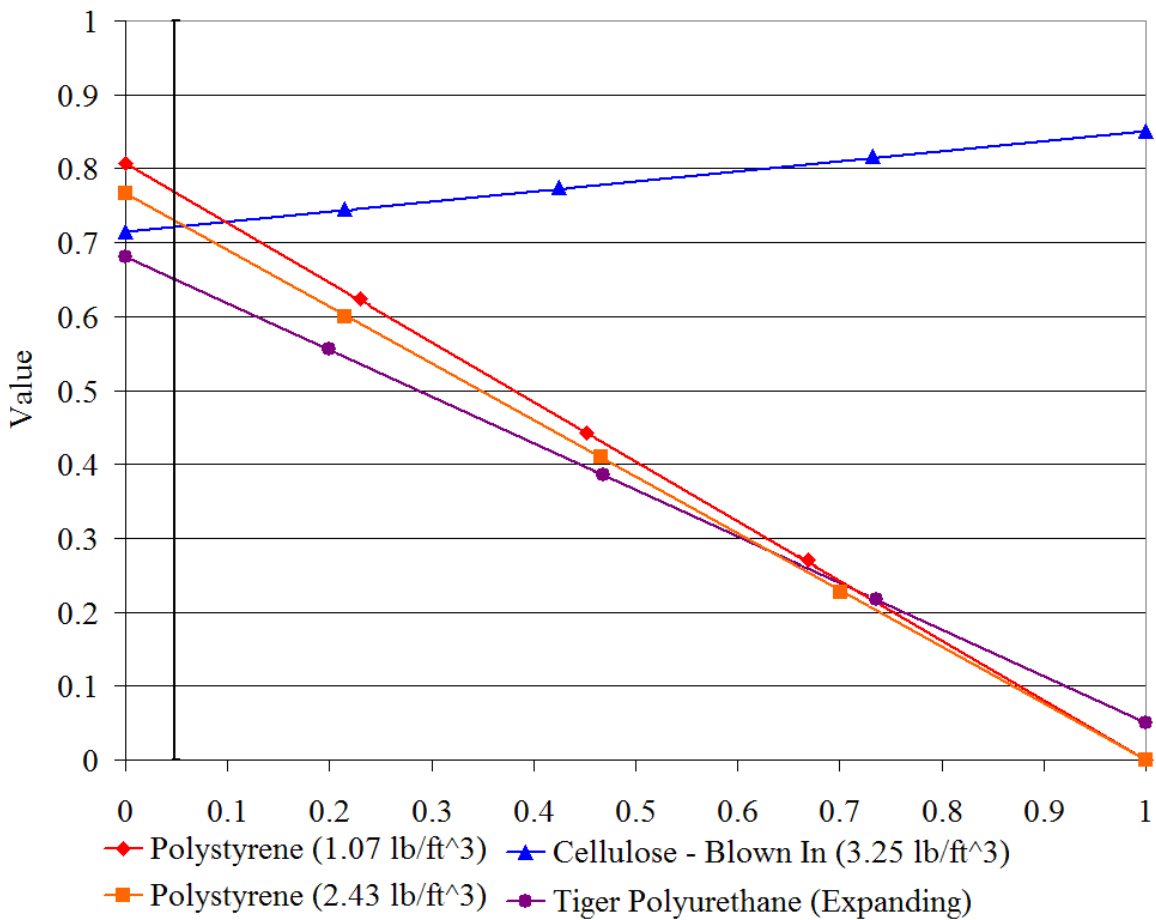

Figure 4.11. Sensitivity of Percent Recycled Material (Climate Zone 3)

The sensitivity analysis for percent hazardous material is similar to that of the previous measure. The current weight is 0.048 and would need to increase to 0.0902 in order to change the decision from low density polystyrene to cellulose. Once again, this measure is not significant enough to warrant a change of 88 percent. Therefore, the decision is not sensitive to changes in weight of percent hazardous material.

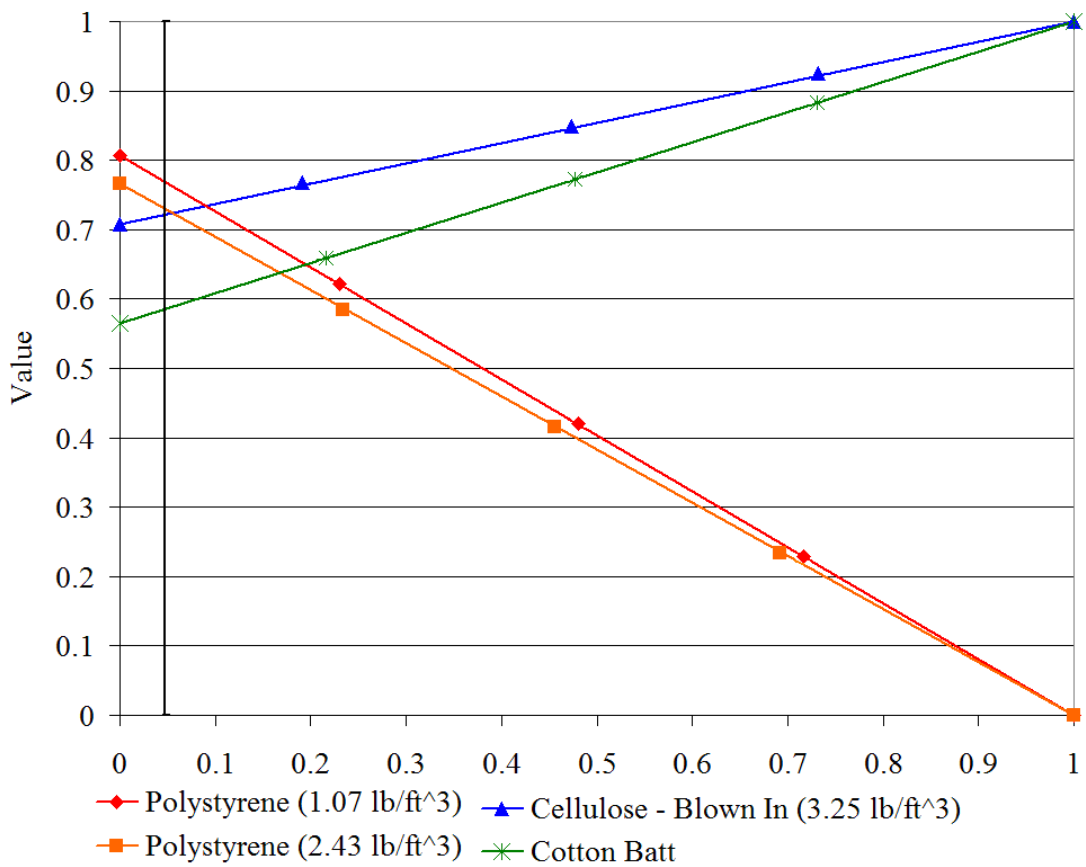

Figure 4.12. Sensitivity of Percent Hazardous Material (Climate Zone 3)

The sensitivity analysis for permeability is shown in Figure 4.13. The current weight is 0.095. The highest ranked alternative would change from low density polystyrene to cellulose if the weight was decreased by 46 percent. This change is large enough to conclude that the decision is not sensitive to this measure.

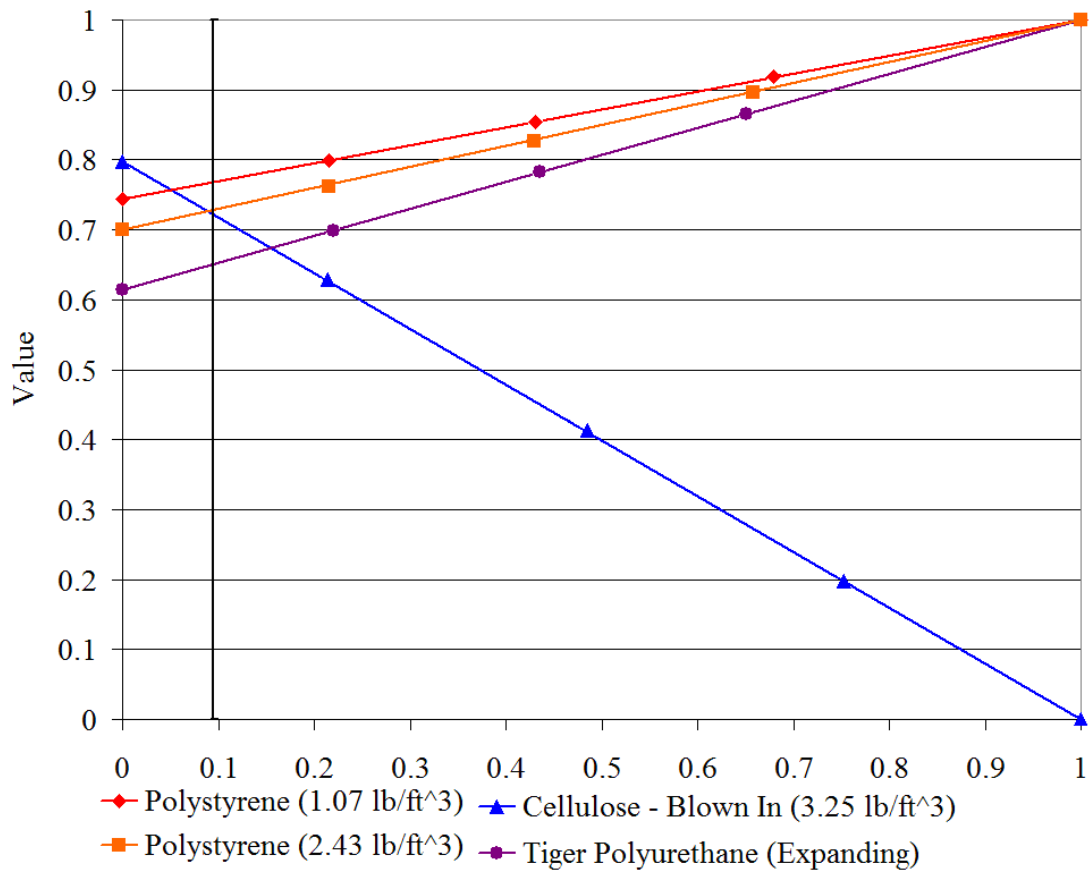

Figure 4.13. Sensitivity of Permeability (Climate Zone 3)

4.4 Material Cost Per Value Analysis

This section includes a cost benefit analysis to determine which alternative provides the highest amount of value per dollar. The amounts listed in Table 4.2 include the cost of material, labor, equipment, profit, and overhead for a square foot of product with an R-value equal to 11. This data was obtained from RSMeans, which does not differentiate the cost of materials with respect to the density of the product. Therefore, in the case of alternatives which have multiple densities, only the material with the highest value was considered. Additionally, the price of cotton insulation was not available in RSMeans. Therefore, manufacturer’s material costs were used in conjunction with the labor cost of fiberglass batt because the installation is similar and would likely have a similar cost. Cellulose insulation has the highest value per cost for all three climates.

Table 4.2. Cost per Value of Alternatives – Minot, North Dakota (RSMeans, 2005)

Alternative	Facing	Cost	Value	Value/Cost
Cellulose Spray-In	Unfaced	0.4	0.687	1.72
Fiberglass Blown In	Unfaced	0.53	0.541	1.02
Rock Wool	Unfaced	0.56	0.561	1.00
Cotton Batt	Unfaced	0.88	0.537	0.61
Polyurethane	Unfaced	0.96	0.553	0.58
Fiberglass Batt	Unfaced	0.69	0.371	0.54
Fiberglass Batt	Kraft	0.6	0.309	0.52
Fiberglass Batt	Foil	0.8	0.309	0.39
Fiberglass Rigid Board	Unfaced	1.88	0.543	0.29
Polystyrene	Unfaced	2.56	0.68	0.27

Table 4.3. Cost Per Value of Alternatives – Dayton, Ohio (RSMeans, 2005)

Alternative	Facing	Cost	Value	Value/Cost
Cellulose Spray-In	Unfaced	0.4	0.722	1.81
Fiberglass Blown In	Unfaced	0.53	0.599	1.13
Rock Wool	Unfaced	0.56	0.593	1.06
Cotton Batt	Unfaced	0.88	0.586	0.67
Fiberglass Batt	Unfaced	0.69	0.65	0.94
Fiberglass Batt	Kraft	0.6	0.381	0.64
Polyurethane	Unfaced	0.96	0.46	0.48
Fiberglass Batt	Foil	0.8	0.381	0.48
Fiberglass Rigid Board	Unfaced	1.88	0.6	0.32
Polystyrene	Unfaced	2.56	0.768	0.30

Table 4.4. Cost Per Value of Alternatives – Niceville, Florida (RSMeans, 2005)

Alternative	Facing	Cost	Value	Value/Cost
Cellulose Spray-In	Unfaced	0.4	0.736	1.84
Fiberglass Blown In	Unfaced	0.53	0.631	1.19
Rock Wool	Unfaced	0.56	0.588	1.05
Polyurethane	Unfaced	0.96	0.748	0.78
Cotton Batt	Unfaced	0.88	0.648	0.74
Fiberglass Batt	Unfaced	0.69	0.51	0.74
Fiberglass Batt	Kraft	0.6	0.427	0.71
Fiberglass Batt	Foil	0.8	0.427	0.53
Fiberglass Rigid Board	Unfaced	1.88	0.633	0.34
Polystyrene	Unfaced	2.56	0.649	0.25

4.5 Comparison of Total Value and Cost per Value.

Total value allows the decision-maker to compare the alternatives based solely on the objectives and measures. However, cost is a fundamental aspect of virtually all construction projects. Therefore, cost per value offers critical information to the decision-maker and may be a better indicator of which alternative is best.

Chapter 5 – Findings and Conclusions

This chapter provides answers to the research questions presented in Chapter 1. In addition, the strengths and weaknesses of the decision model are addressed. Finally, this chapter provides recommendations for future work.

5.1 Answer to Research Questions

Sixteen thermal building insulation alternatives were considered for this research. Based on overall value, the highest ranked alternative for all three climate zones is low density polystyrene. Although the top ranked alternative remained constant, there were changes in the rankings based on climate. Cellulose ranked second in climate zone 1 but fell to third in climate zone 3; it fell an additional spot in climate zone 5. High density polystyrene replaced cellulose as the second ranked alternative in climate zone 3 and 5. Polyurethane expanding foam placed third in climate zone 5. Fiberglass batt products consistently ranked the lowest.

Second tier sensitivity analysis indicates that low density polystyrene is slightly sensitive to changes in the weights of environmental impact and impact on human health. Sensitivity analysis on the measures reveals a slight sensitivity to some measures but the required weight change is large enough to conclude that the decision is insensitive to potential weight changes.

Low density polystyrene is the highest ranked alternative in each of the three climates because it has the highest effective R-value, provides excellent resistance to infiltration, and has a low flame spread rating. Additionally, polystyrene will not absorb

water, which will help prevent the growth of mold on adjacent surfaces. Not surprisingly, these properties were important to the decision-maker and were heavily weighted measures.

Even though polystyrene alternatives ranked high, its upfront cost is also high giving it the lowest value per cost ratio. Cellulose, a consistently high ranked alternative, has the highest value per cost ratio in all three climate zones.

5.2 Model Strengths

Previously published literature identified the deviation between a material's rated R-value and that of observed thermal resistance at varied temperature gradients. However, this research effort resulted in the first published attempt to quantify the deviations based on actual climate data. The equation for quantifying effective R-value as a percentage was a result of this research. Any identical or substantially similar technique has not been published to the knowledge of the author.

In addition, this model can be used by all DoD decision-makers for any climate. The model is extremely flexible and can easily be modified for differing preferences. Furthermore, sensitivity analysis can identify weaknesses and strengths of each alternative. Parameters which have not been included in this research can be added without difficulty. The model is also operable for those familiar with fundamental engineering principles.

5.3 Model Weaknesses

Only existing products can be evaluated with this decision model. Additionally, data availability for new products could be an issue. This is of particular importance for effective R-value and embodied energy because both require a great deal of resources if the data is not readily available. The categorical value function for infiltration was obtained from a single source which categorized each type of material. While the data makes intuitive engineering sense, the author did not explain the method by which each type alternative was measured. The lack of specific information regarding the categories resulted in the assumption that the relationship between the categories and corresponding value was linear. An exponential monotonically increasing curve for the flame spread and smoke generation single dimensional value functions may have been more representative of the risks associated with fire. An exponential curve would have provided the decision-maker a means to account for more specific levels of risk. However, specific risks were unknown and a linear relationship was assumed. The foil facing of fiberglass batt provides some degree of protection from radiative heat transfer. The primary focus of this research was on the thermal insulation and did not consider the effect of foil facing. Additionally, schedule is an important aspect of any project. This model does not consider the time required to install the materials.

5.4 Areas for Future Research

The primary purpose of thermal building insulation is to reduce heat transfer through the building envelope. However, sufficient research on infiltration is not available. This model would benefit greatly from a method which quantifies the

infiltration of each material. Actual infiltration data could be obtained by constructing adjacent identical buildings that differ only in insulation type. A government military family housing project would be well suited for this type of research; however, privatization would likely complicate attempts to specify insulation. An infiltration rating system could then be developed, which could eventually lead to an ASTM standard. The addition of a method to quantify infiltration could then be used to conduct a long-term energy consumption analysis and cost benefit analysis.

5.5 Final Conclusions

According to the model developed for this research, low density polystyrene tops the rankings in all three climate zones. Effective R-value appears to have an impact on insulation rankings in extreme climates but the benefits of higher effective R-values are insignificant in moderate climates. Interestingly, fiberglass batt products ranked low in all three climate zones. Overall, the model clearly illustrates the variance between alternatives. Therefore, DoD decisions-makers who are cost sensitive and have similar value objectives should consider specifying cellulose thermal building insulation in future projects. Based purely on value, low density polystyrene is the best alternative.

Appendix A: Monthly Average Temperature

Table A1: Average Monthly Temperatures – Minot, North Dakota
(www.weatherreports.com, 2008)

Minot	Jan	Feb	Mar	Apr	May	Jun	Jul	Aug	Sep	Oct	Nov	Dec
High	-3	2	14	29	41	51	55	53	42	32	17	2
Low	16	22	34	52	66	75	81	80	68	55	36	21
Average	6.5	12	24	40.5	53.5	63	68	66.5	55	43.5	26.5	11.5

Table A2: Average Monthly Temperatures – Dayton, Ohio
(www.weatherreports.com, 2008)

Dayton	Jan	Feb	Mar	Apr	May	Jun	Jul	Aug	Sep	Oct	Nov	Dec
High	31	35	46	59	70	80	83	81	75	63	50	36
Low	14	17	28	38	49	58	62	59	53	41	32	21
Average	22.5	26	37	48.5	59.5	69	72.5	70	64	52	41	28.5

Table A3: Average Monthly Temperatures – Niceville, Florida
(www.weatherreports.com, 2008)

Niceville	Jan	Feb	Mar	Apr	May	Jun	Jul	Aug	Sep	Oct	Nov	Dec
High	39	41	48	53	60	68	69	69	66	55	44	41
Low	62	64	71	78	86	89	91	91	87	80	69	62
Average	50.5	52.5	59.5	65.5	73	78.5	80	80	76.5	67.5	56.5	51.5

Appendix B: Single Dimensional Value Functions

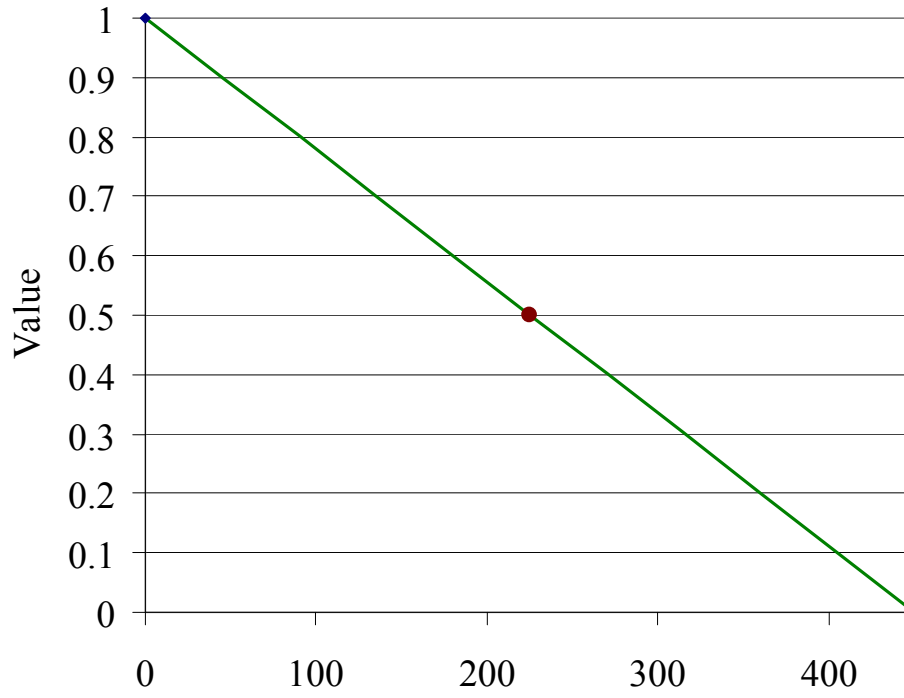

Figure B.1. Smoke Generation SDVF

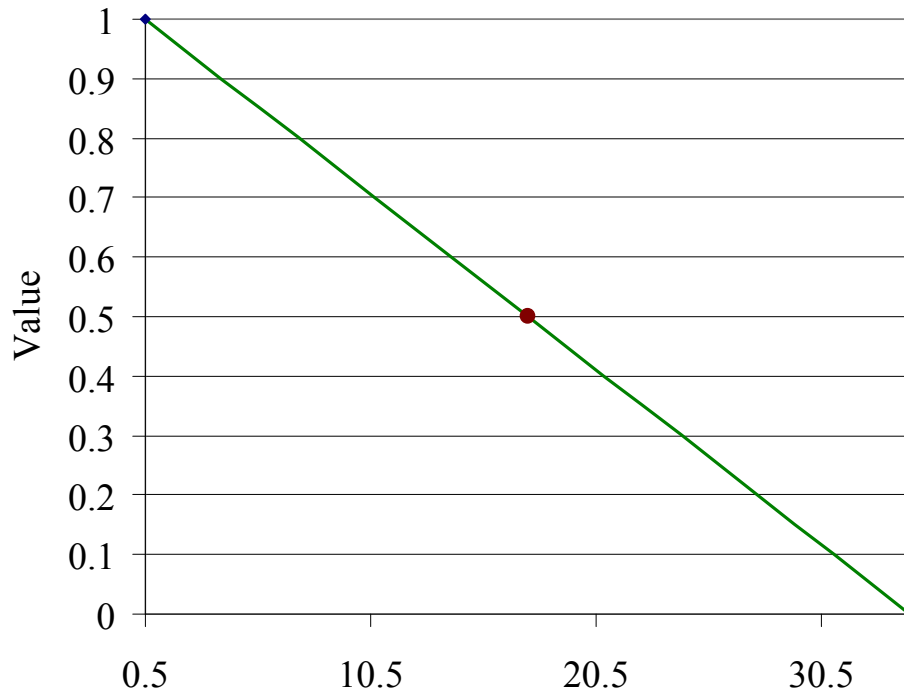

Figure B.2. Embodied Energy SDVF

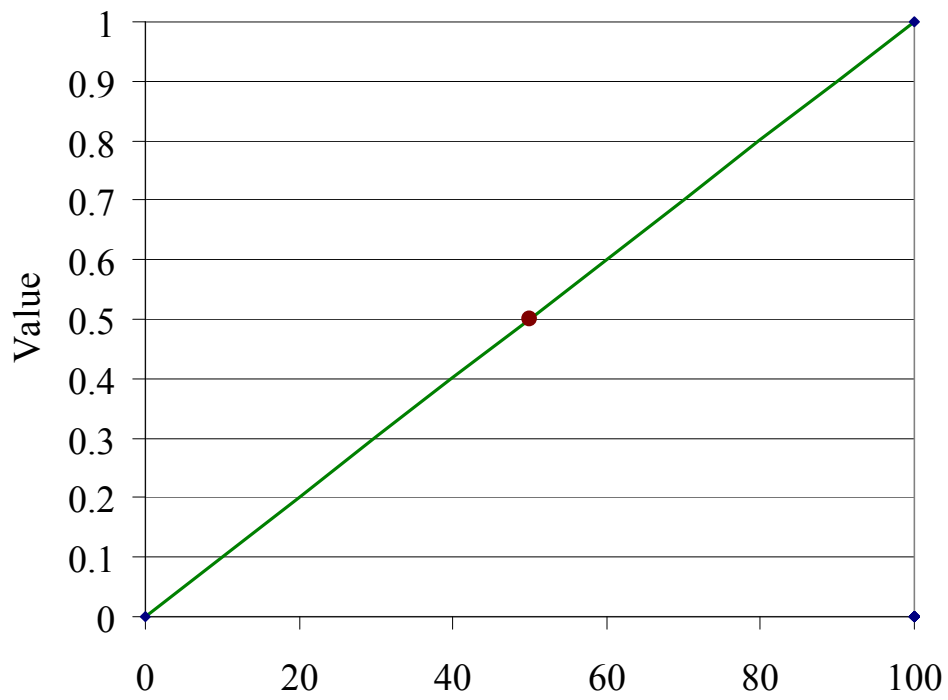

Figure B.3. Percent Recycled Material SDVF

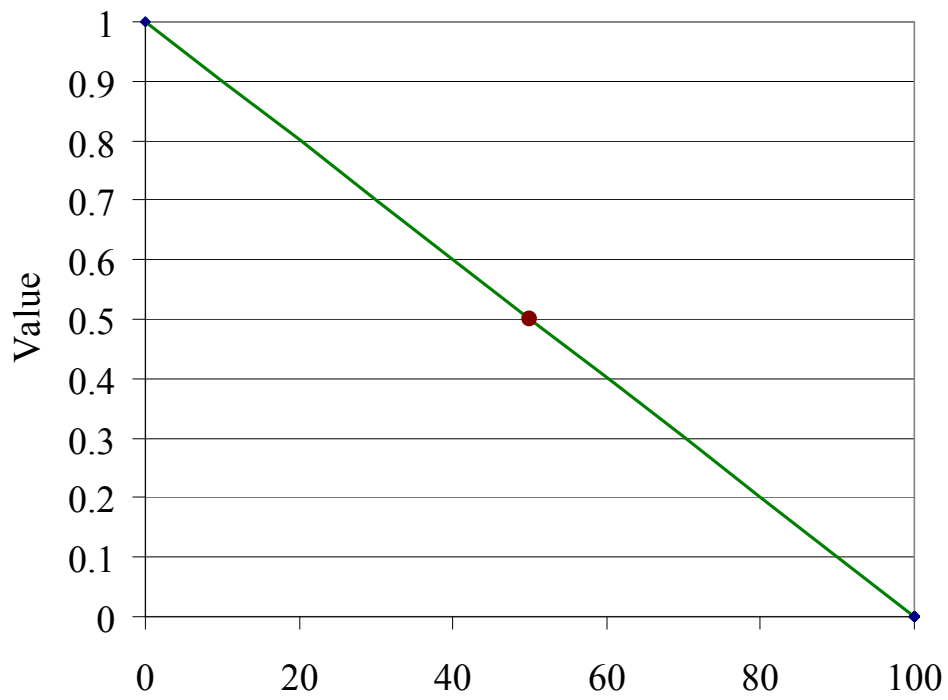

Figure B.4. Percent Hazardous Material SDVF

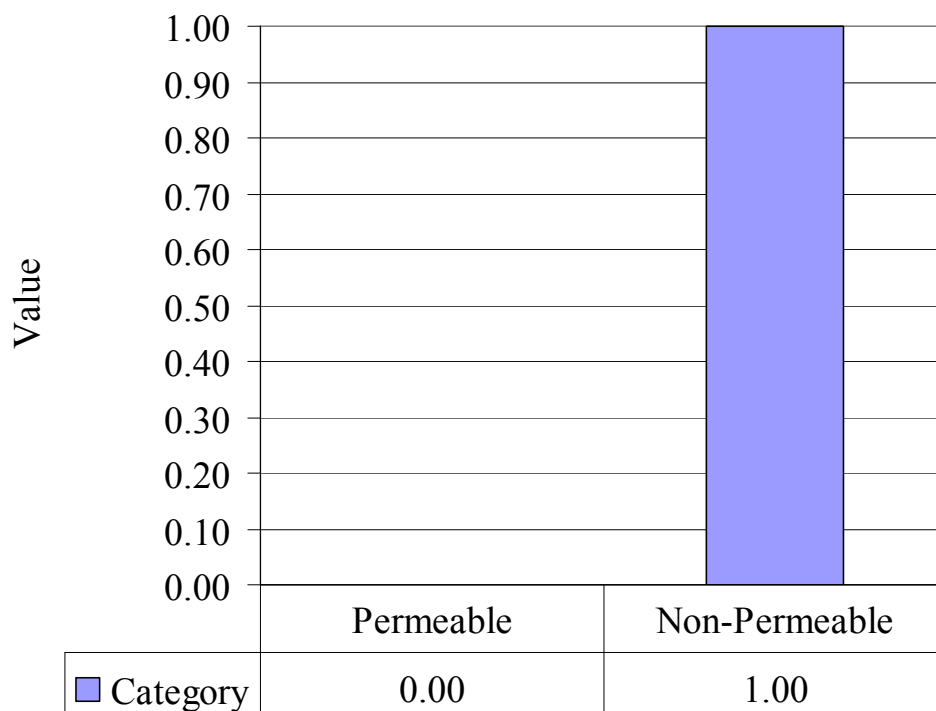

Figure B.5. Permeability SDVF

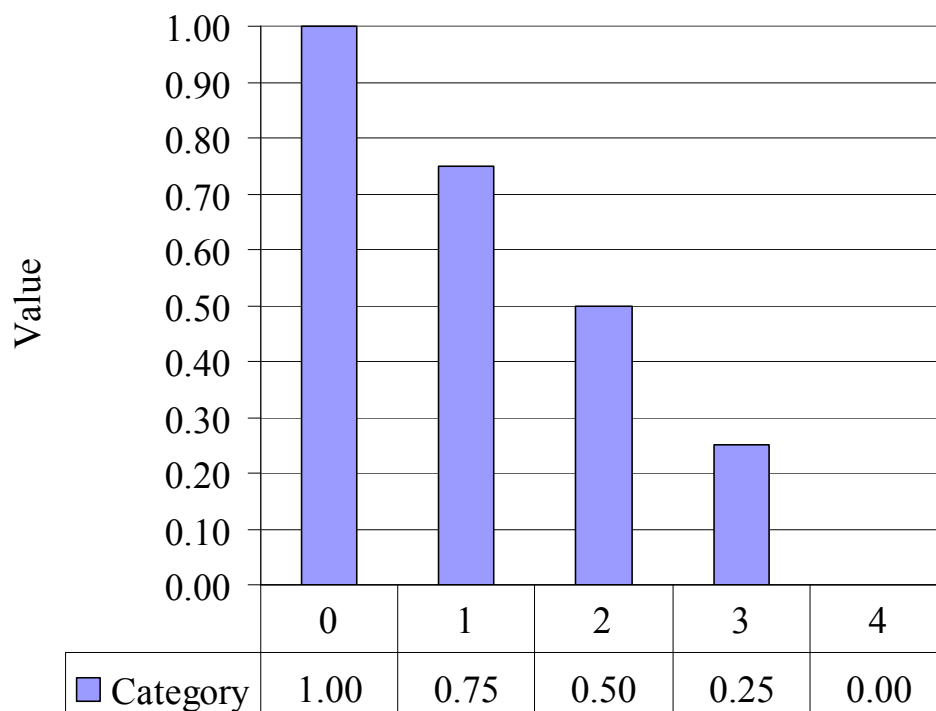

Figure B.6. MSDS Health Rating SDVF

Appendix C: Global Weights for Climate Zones 1 and 5

Table C.1. Weights for Climate Zone 1 (Minot North Dakota)

Lowest Tier Objective	Multiple	Weight
Embodied Energy	1	0.043478261
Percent Recycled Material	1	0.043478261
MSDS Health Rating	1	0.043478261
Percent Hazardous Material	1	0.043478261
STC Rating	1	0.043478261
Permeability	1	0.043478261
Flame Spread	3	0.130434783
Smoke Development	3	0.130434783
Resistance to Infiltration	5	0.217391304
Effective R-Value	6	0.260869565
	23	1

Table C.2. Weights for Climate Zone 5 (Niceville Florida)

Lowest Tier Objective	Multiple	Weight
Embodied Energy	1	0.05
Percent Recycled Material	1	0.05
MSDS Health Rating	1	0.05
Percent Hazardous Material	1	0.05
STC Rating	1	0.05
Permeability	3	0.15
Flame Spread	3	0.15
Smoke Development	3	0.15
Resistance to Infiltration	4	0.2
Effective R-Value	2	0.1
	20	1

Appendix D: Sensitivity Analysis of Non-Sensitive Measures

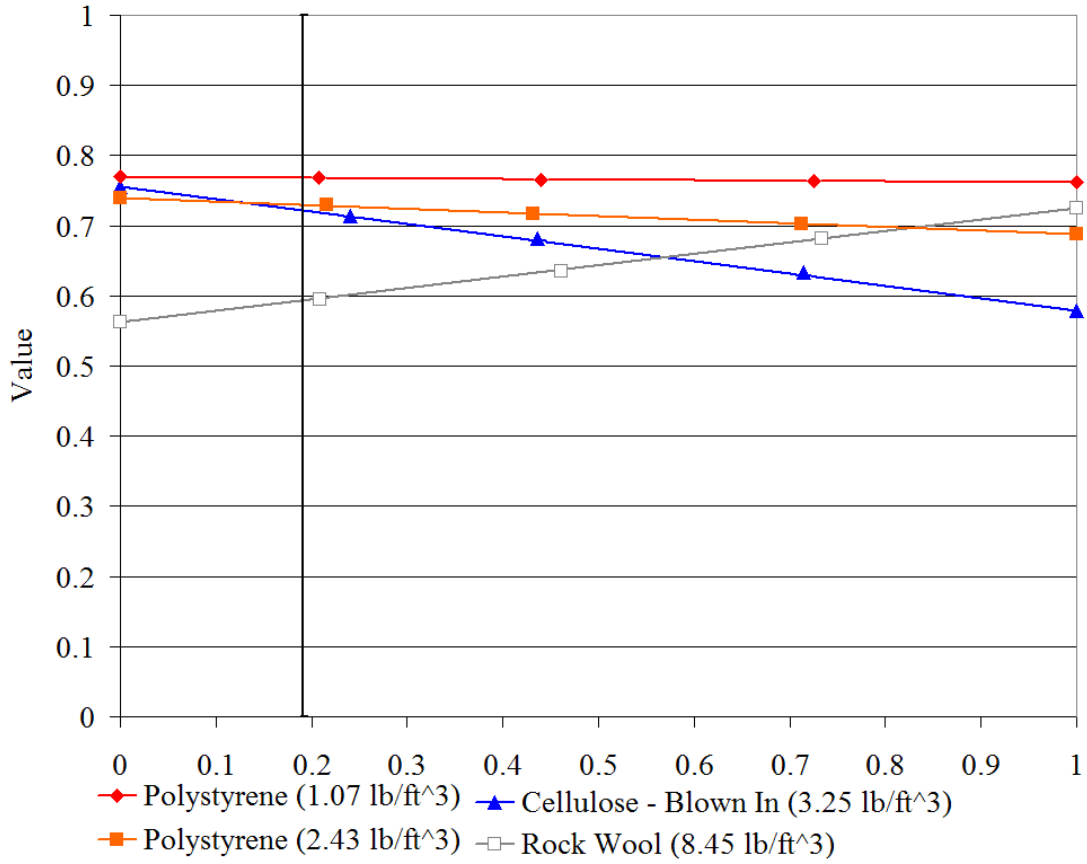

Figure D.1. Sensitivity of Effective R-Value (Climate Zone 3)

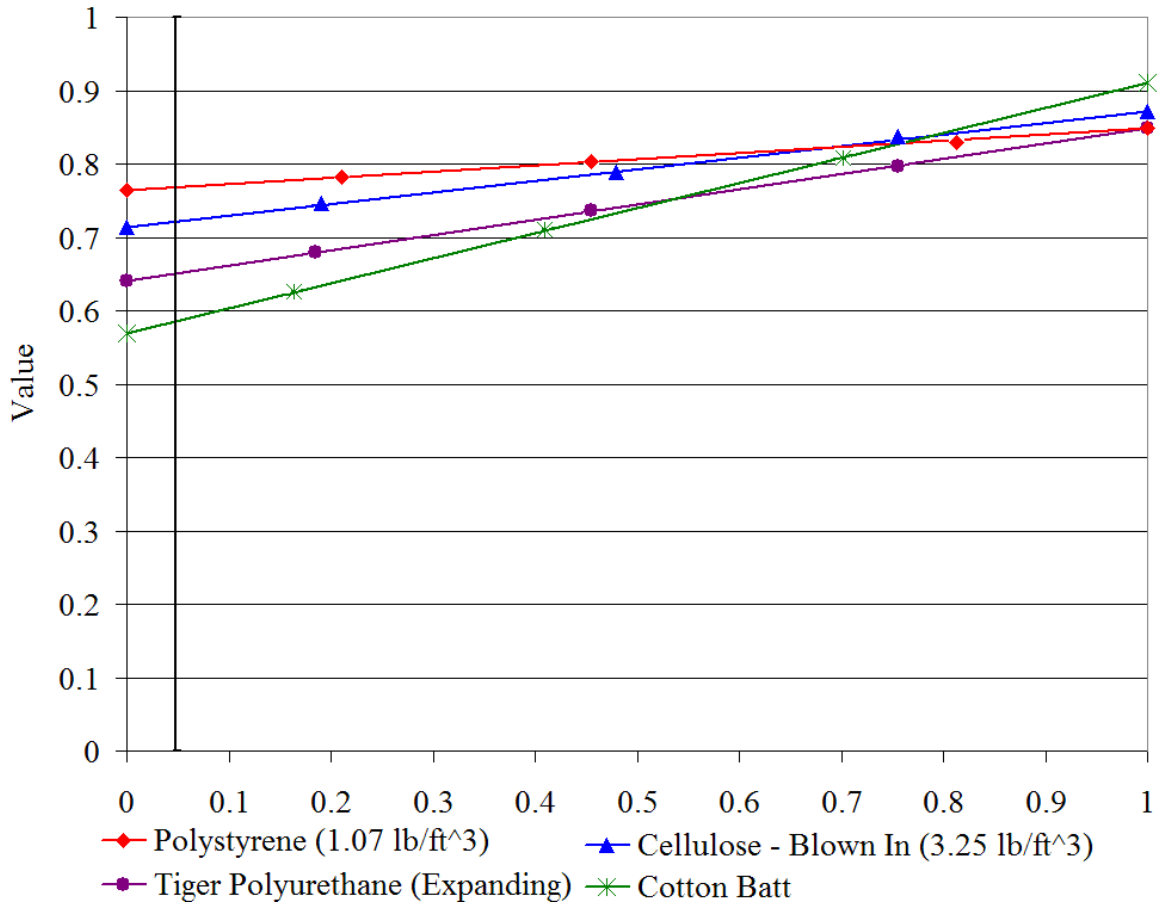

Figure D.2. Sensitivity of Sound Transmission Class (Climate Zone 3)

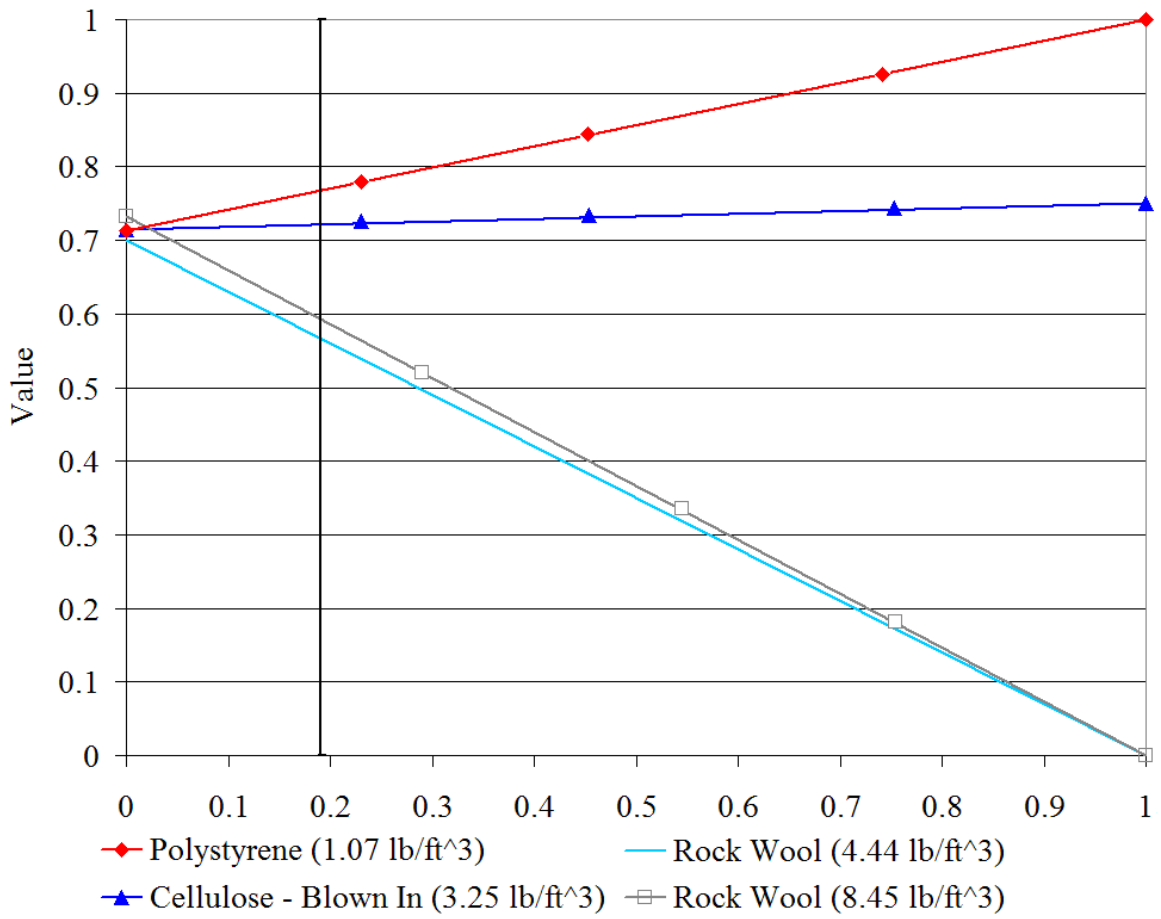

Figure D.3. Sensitivity of Resistance to Infiltration (Climate Zone 3)

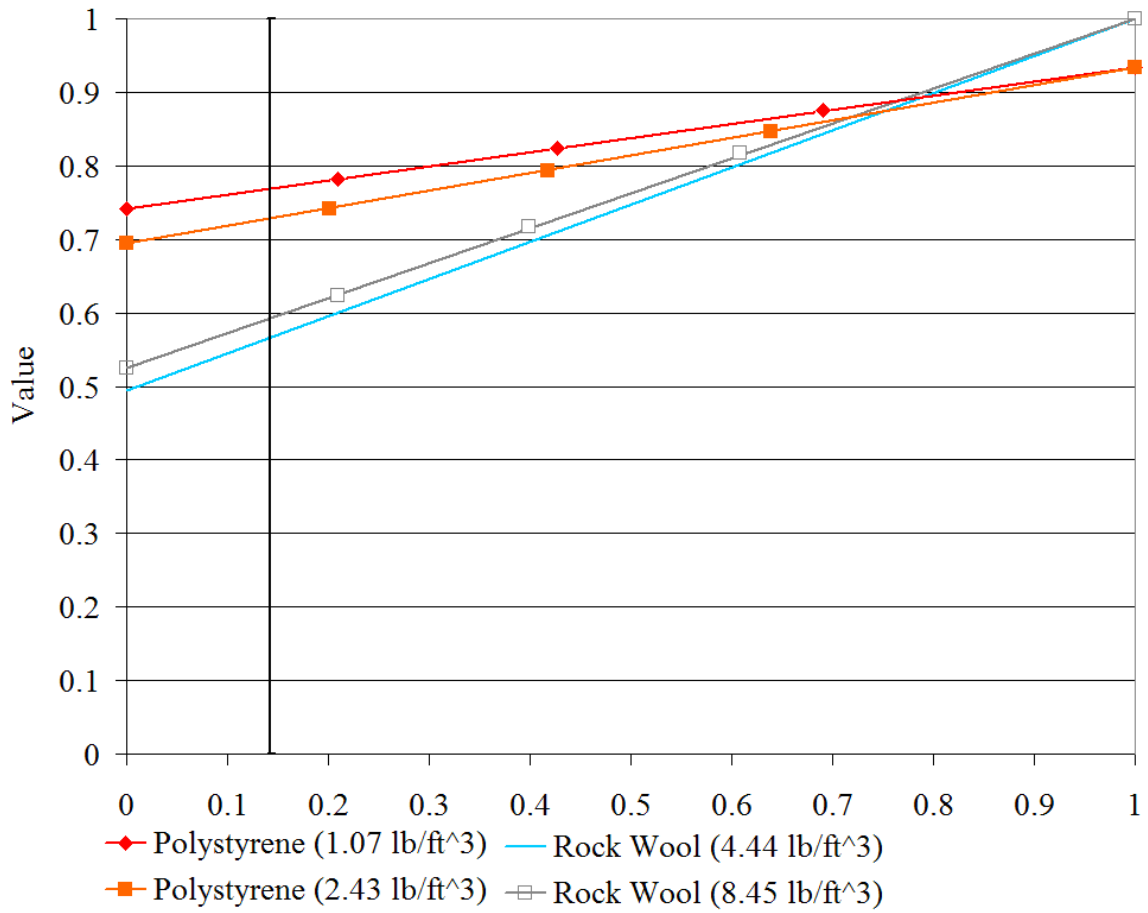

Figure D.4. Sensitivity of Flame Spread (Climate Zone 3)

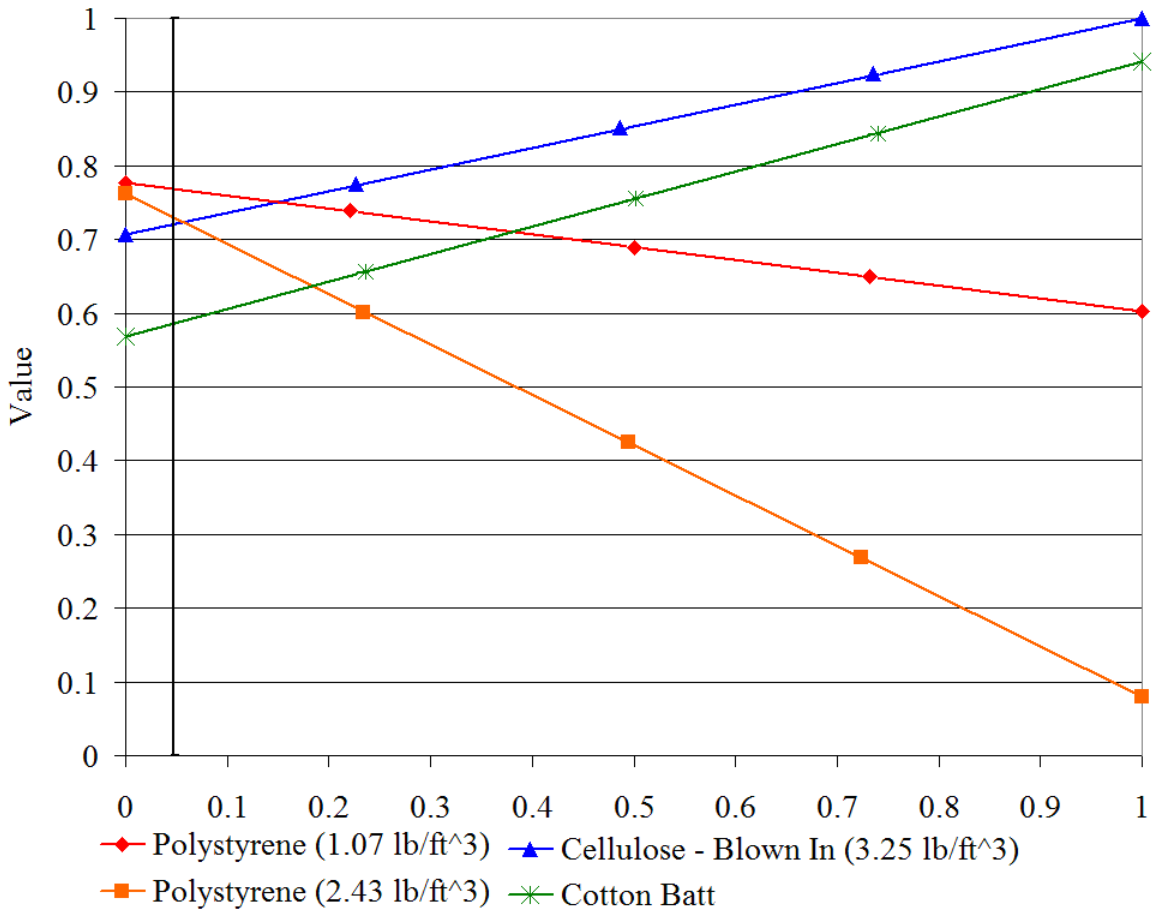

Figure D.5. Sensitivity of Embodied Energy (Climate Zone 3)

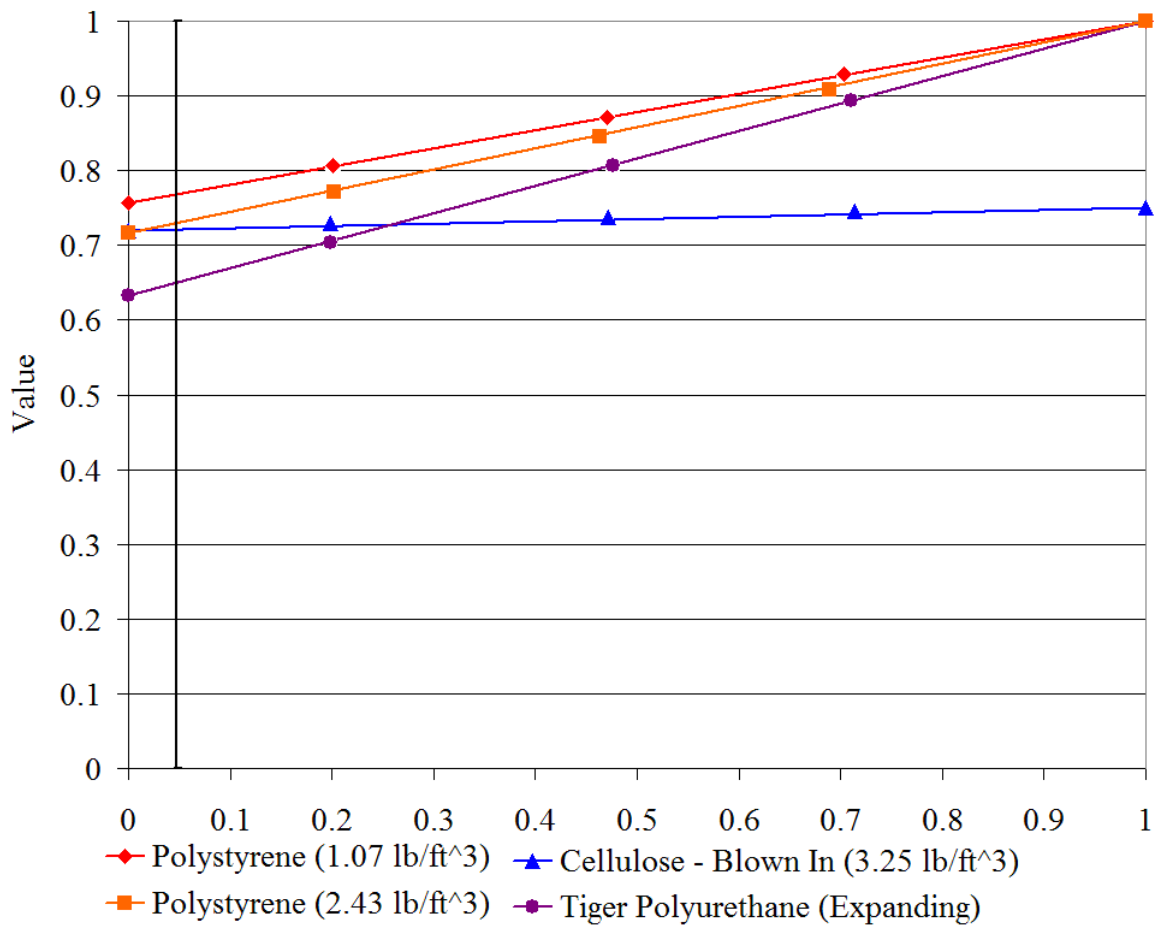

Figure D.6. Sensitivity of MSDS Health Rating (Climate Zone 3)

Appendix E: Effective R-values for Climate Zones 1 and 5

Table E.1. Effective R-values for Climate Zones 1 and 3

	Climate Zone 1	Climate Zone 5
Alternative Name	Effective R-Value	Effective R-Value
Fiberglass Batt - Unfaced (.82 lb/ft ³)	87.300	96.400
Fiberglass Batt - Foil Faced (.82 lb/ft ³)	87.300	96.400
Fiberglass Batt - Kraft Faced (.82 lb/ft ³)	87.300	96.400
Fiberglass - Blown In (.82 lb/ft ³)	87.300	96.400
Fiberglass - Blown In (1.68 lb/ft ³)	89.300	97.000
Fiberglass Rigid Board (1.68 lb/ft ³)	89.300	97.000
Fiberglass Rigid Board (3.49 lb/ft ³)	92.500	98.000
Cellulose - Blown In (3.25 lb/ft ³)	91.300	97.600
Rock Wool (4.44 lb/ft ³)	90.200	97.300
Rock Wool (8.45 lb/ft ³)	93.400	98.200
Dow Polyurethane (Expanding)	88.200	96.700
Tiger Polyurethane (Expanding)	88.200	96.700
Polystyrene (1.07 lb/ft ³)	94.000	98.400
Polystyrene (2.43 lb/ft ³)	92.890	98.100
Polystyrene (Expanding, 2.4 lb/ft ³)	93.500	98.100
Cotton Batt	89.000	97.000

Bibliography

- Al-Homoud, Mohammad S. Performance Characteristics and Practical Applications of Common Building Thermal Insulation Materials. *Building and Environment* 40: 353-366 (2005).
- ASTM Standard C 1043-06. *Standard Practice for Guarded-Hot-Plate Design Using Circular Line-Heat Sources*. ASTM International, West Conshohocken, PA, 2006.
- Benignus, Vernon A. Andrew M. Geller, William K. Boyes, and Philip J. Bushnell. Human Neurobehavioral Effects of Long-Term Exposure to Styrene: A Meta-Analysis. *Environmental Health Perspectives*. 113: 532-538. 27 January 2005.
- Bishop, Paul L. *Pollution Prevention: Fundamentals and Practice*. Prospect Heights, IL: Waveland Press Inc., 2004.
- Bouyssou, Denis, Marchant, Thierry, Pirlot, Marc, Tsoukias, Alexis, and Vincke, Philippe, *Evaluation and Decision Models with Multiple Criteria*. New York, NY: Springer Science+Business Media, Inc., 2006.
- Budaiwi, I., Abdou A., and Al-Homoud, M. Variations of Thermal Conductivity of Insulation Materials Under Different Operating Temperatures: Impact on Envelope-Induced Cooling Load. *Journal of Architectural Engineering*: 125-132 (December 2002).
- Burmeister, Louis C. *Convective Heat Transfer 2nd ed.* New York, NY: John Wiley and Sons, Inc., 1993.
- Bush, George W. Presidential Documents. Executive Order 13432. *Strengthening Federal Environmental, Energy, and Transportation Management*. Federal Register. Washington: GPO. 24 January 2007.
- Chang, Shu-Chi, Chris Scheuer, and Jake Swenson. Life Cycle Assessment of Residential Insulation Materials: A Comparative Analysis of Cellulose, Cotton, and Fiberglass Insulation Products for Insulation of Residential Walls. *Industrial Ecology*: April 16, 2001.
- Chebil, S., N. Galanis, and R. Zmeureanu, International Building Performance Simulation Association - Sim 2002 Conference, *Computer Simulation of Air Infiltration effects on Heat Transfer in Multilayered Walls*, 13 Sep 2002.
- Collaborative for High Performance Schools. *Best Practices Manual: Volume 1, Planning*. San Francisco CA. 2006.

- Consoli, F., D. Allen, I. Bousted, J. Fava, W. Franklin, A.A. Jensen, N. Oude, R. Parrish, R. Perriman, D. Postlethwaite, B. Quay, J. Seguin, and B. Vigon. Guidelines for Life Cycle Assessment: A Code of Practice. *Society of Environmental Toxicology and Chemistry*. Pensacola, FL, 1993.
- Curran, Marry Ann. *Environmental Life-Cycle Assessment*. McGraw-Hill Publishing. New York, NY, 1996.
- Department of Commerce. U.S. Census Bureau. U.S. and World Population Clocks. <http://www.census.gov/main/www/popclock.html>. 15 September 2007.
- Department of Energy. Energy Information Administration. *Annual Energy Review 2006*. Washington: GPO. June 2007.
- . Energy Information Administration. *Annual Energy Outlook 2007*. Washington: GPO. February 2007
- . Energy Information Administration. *Annual Energy Outlook 2007 with Projections to 2030*. Washington: GPO. February 2007.
- Department of Commerce. *State, Regional, and National Monthly Heating Degree Days, Weighted by Population (2000 Census)*, Historical Climatology Series NO. 5-1. GPO Washington D.C. 15 August 2002.
- Department of Health, Education, and Welfare. *Criteria for a recommended standard: Occupational Exposure to Fibrous Glass*. Washington: GPO. April 1977.
- Environmental Protection Agency. *A Brief Guide to Mold, Moisture, and Your Home*. Washington: GPO. 2002.
- . *Indoor Air Facts No. 4: Sick Building Syndrome*. Washington: GPO. 1991.
- . *Indoor Air Pollution: An Introduction for Health Professionals*. Washington: GPO. 1994.
- . *Mold Resources*. <http://www.epa.gov/mold/moldresources.html>. December 2007.
- Filippin, C. and A. Beascochea. Performance Assessment of Low Energy Buildings in Central Argentina. *Energy and Buildings*, 39: 546-557 (May 2007)
- Gale, Bradley W. Interview with the decision-maker. 15 November 2007.
- Graves, Ronald S., Wilkes, K.E., and McElroy, D. L. *Thermal Resistance of Attic Loose-Fill Insulations Decreases Under Simulated Winter Conditions*. Oak Ridge National Laboratory: May 1994.

- Hardin, Garrett. The Tragedy of the Commons. *Science* 162:1243-1248. 13 December 1968.
- Harper, Charles A. *Handbook of Building Materials for Fire Protection*. McGraw-Hill. New York NY. 2004.
- Harvey, L.D. Danny. Net Climatic Impact of Solid Foam Insulation Produced with Halocarbon and Non-Halocarbon Blowing Agents. *Building and Environment* 42:2860-2879. 2007.
- Incropera, Frank and DeWitt, David. *Introduction to Heat Transfer 4th ed.* John Wiley and Sons, Inc., 1996.
- Intergovernmental Panel on Climate Change. *Working Group I Technical Summary*. 2001.
- International Organization for Standardization. ISO 14000 Series of Standards. *International Organization for Standardization: Document 14041*. 1998
- Katz, Gregory H. *Green Building Costs and Financial Benefits*. Massachusetts Technology Collaborative. Westborough MA. 2003
- Keeney, Ralph L. *Value-Focused Thinking: A Path to Creative Decision making*. Cambridge MA. Harvard University Press, 1992.
- Kirkwood, Craig W. *Strategic Decision Making: Multiobjective Decision Analysis with Spreadsheets*. Duxbury Press, Belmont, CA, 1997.
- Malthus, Thomas. *An Essay on the Principle of Population*. John Murray. London England. 1798
- McCourt, Michael J. *A Decision Model for Selecting Energy Efficient Technologies for Low-Sloping Roof Tops Using Value-Focused Thinking*. MS thesis, AFIT/GEM/ENS/07-03. School of Systems and Engineering Management, Air Force Institute of Technology (AU), Wright-Patterson AFB OH, March 2007.
- Memorandum of Understanding. *Guiding Principles for Federal Leadership in High Performance and Sustainable Buildings*. 23 February 2006.
- Meyers, Glen E. *Analytical Methods in Conduction Heat Transfer*. New York, NY: McGraw-Hill, Inc., 1971.
- Modest, Michael F. *Radiative Heat Transfer*. New York, NY: McGraw-Hill, Inc., 1993.

- Morgan, Chris, *Design and Detailing for Airtightness; SEDA Design Guides for Scotland: No 2*. Scottish Ecological Design Association. 2006.
- National Institute of Building Sciences. *Whole Building Design Guide, Design Objectives*. 9 October 2007 <http://www.wbdg.org/design/designobjectives.php>
- North American Insulation Manufacturers Association. *Noise Control, Sound Advice for Today's Families*. Publication #B1476. Alexandria, VA. December 2004.
- Oversee.net. http://www.weatherreports.com/United_States/OH/dayton/averages.html, 4 January 2008.
- http://www.weatherreports.com/United_States/ND/minot/averages.html, 4 January 2008.
- http://www.weatherreports.com/United_States/FL/niceville/averages.html, 4 Jan 2008.
- Pratt, David M. *Selecting Energy Efficient Building Envelope Retrofits to Existing Department of Defense Buildings Using Value Focused Thinking*. MS thesis, AFIT/GEM/ENV/06M-14. School of Systems and Engineering Management, Air Force Institute of Technology (AU), Wright-Patterson AFB OH, March 2006.
- Precast/Prestressed Concrete Institute. *Precast/Prestressed Concrete Institute, Designer's Notebook - Energy Conservation*, Chicago, IL, 2005.
- Quayle, Robert G., and Diaz, Henry F. Heating Degree Day Data Applied to Residential Heating Energy Consumption. *Journal of Applied Meteorology*: 241-246 (March 1980).
- RSMeans Company Inc. Repair and Remodeling Cost Data. Kingston, MA. RSMeans Publishers. 2005.
- Siegel, Robert and Howell, John R. *Thermal Radiation Heat Transfer 3rd ed*. Washington D.C.: Hemisphere Publishing Corp., 1992.
- Shoviak, Mark J. *Decision Analysis Methodology to Evaluate Integrated Solid Waste Management Alternatives for a Remote Alaskan Air Station*. MS thesis, AFIT/GEE/ENV/01M-20. School of Systems and Engineering Management, Air Force Institute of Technology (AU), Wright-Patterson AFB OH, March 2001.
- Smalley Bowen, Ted. Thom Mayne on What's Wrong with LEED. Greensource, (15 November 2007). 5 December 2007 <http://greensource.construction.com/people/071115thommayne.asp#>.
- Turner, Wayne C. *Energy Management Handbook 3rd ed*. Lilburn, GA: The Fairmont Press, Inc., 1997.

- United Nations Framework Convention on Climate Change. *Status of Ratification*. 22 August 2007.
- United States Congress. *Byrd-Hagel Resolution*. Senate Resolution 98. 105th Congress, 1st Session. Washington: GPO, 1997.
- . Housing and Community Development Act of 1974. Public Law No. 93-383, 93rd Congress, 2nd session. Washington: GPO, 1974
- United States Corps of Engineers, Louisville District. *Wright-Patterson Air Force Base, Ohio, Design-Build New AFIT Academic Building*. Construction Specifications. Vol 1. 25 September 2007.
- Vanegas, Jorge A., DuBose, Jennifer R., and Pearce, Annie R. Sustainable Technologies for the Building Construction Industry. *Proc. Symp. on Design for the Global Environment*, Atlanta, GA, Nov 2-4.
- Wegman, David H., Ellen A. Eisen, Xiaohan Hu, Susan R. Woskie, Ralph G. Smith, and David H. Garabrant. Acute and Chronic Respiratory Effects of Sodium Borate Particulate Exposures. *Environmental Health Perspectives*. 102(supplement 7): 119-128. 1994.
- World Health Organization. *Ultraviolet Radiation: Solar Radiation and Human Health. Fact Sheet N°227*. August 1999
- Zarr, Robert R., A History of Testing Heat Insulators at the National Institute of Standards and Technology. *Building and Fire Research Laboratory*. Gaithersburg, MD, 2001.

REPORT DOCUMENTATION PAGE			<i>Form Approved OMB No. 074-0188</i>		
The public reporting burden for this collection of information is estimated to average 1 hour per response, including the time for reviewing instructions, searching existing data sources, gathering and maintaining the data needed, and completing and reviewing the collection of information. Send comments regarding this burden estimate or any other aspect of the collection of information, including suggestions for reducing this burden to Department of Defense, Washington Headquarters Services, Directorate for Information Operations and Reports (0704-0188), 1215 Jefferson Davis Highway, Suite 1204, Arlington, VA 22202-4302. Respondents should be aware that notwithstanding any other provision of law, no person shall be subject to a penalty for failing to comply with a collection of information if it does not display a currently valid OMB control number. PLEASE DO NOT RETURN YOUR FORM TO THE ABOVE ADDRESS.					
1. REPORT DATE (DD-MM-YYYY) 27-03-2008		2. REPORT TYPE Master's Thesis		3. DATES COVERED (From - To) August 2007 - March 2008	
4. TITLE AND SUBTITLE Selecting the Best Thermal Building Insulation Using a Multi-Attribute Decision Model			5a. CONTRACT NUMBER		
			5b. GRANT NUMBER		
			5c. PROGRAM ELEMENT NUMBER		
6. AUTHOR(S) Sotoropolis, Theodore J., Captain, USAF			5d. PROJECT NUMBER		
			5e. TASK NUMBER		
			5f. WORK UNIT NUMBER		
7. PERFORMING ORGANIZATION NAMES(S) AND ADDRESS(S) Air Force Institute of Technology Graduate School of Engineering and Management (AFIT/EN) 2950 Hobson Way, Building 640 WPAFB OH 45433-7765			8. PERFORMING ORGANIZATION REPORT NUMBER AFIT/GEM/ENV/08-M17		
9. SPONSORING/MONITORING AGENCY NAME(S) AND ADDRESS(ES) This section intentionally left blank			10. SPONSOR/MONITOR'S ACRONYM(S) N/A		
			11. SPONSOR/MONITOR'S REPORT NUMBER(S)		
12. DISTRIBUTION/AVAILABILITY STATEMENT APPROVED FOR PUBLIC RELEASE; DISTRIBUTION UNLIMITED.					
13. SUPPLEMENTARY NOTES					
14. ABSTRACT Thermal building insulation has traditionally been viewed as a means to reduce thermal conductivity through the building envelope. Builders typically choose the least expensive material which meets the specifications in order to remain competitive. Other factors regarding long term health and environmental consequences are typically dismissed. However, a recent shift toward sustainability requires that architects and engineers take a more responsible approach to building design. This research takes a holistic approach to selecting thermal building insulation through the use of a multi-attribute decision model. Several types of insulating products from a variety of manufacturers were investigated in order to determine the best insulation alternative for the new Air Force Institute of Technology (AFIT) academic facility at Wright-Patterson Air Force Base based upon the objectives of an Air Force decision-maker. Human health and environmental impacts were considered in addition to those traditionally associated with thermal building insulation. A multi-attribute decision model was chosen for this research because of the numerous alternatives and competing objectives. The results show that polystyrene ranks highest according to value; however, polystyrene has the highest upfront cost. Wet spray cellulose ranks lower but a low upfront cost give it highest value per cost ratio in climate zone 3. Climate appears to be a significant factor in extreme climates.					
15. SUBJECT TERMS Thermal building insulation, Multi-attribute decision analysis					
16. SECURITY CLASSIFICATION OF:			17. LIMITATION OF ABSTRACT	18. NUMBER OF PAGES	19a. NAME OF RESPONSIBLE PERSON
a. REPORT	b. ABSTRACT	c. THIS PAGE			19b. TELEPHONE NUMBER (Include area code)
U	U	U	UU	119	Alfred E. Thal, USAF (937) 255-6565, ext 7401 (al.thal@afit.edu)
					Standard Form 298 (Rev. 8-98) Prescribed by ANSI Std. Z39-18