

3-14-2014

# A Proper Splitting Theater Distribution Model for Improving Force Flow Analysis

Charles M. Flores

Follow this and additional works at: <https://scholar.afit.edu/etd>

---

## Recommended Citation

Flores, Charles M., "A Proper Splitting Theater Distribution Model for Improving Force Flow Analysis" (2014). *Theses and Dissertations*. 673.  
<https://scholar.afit.edu/etd/673>

This Thesis is brought to you for free and open access by the Student Graduate Works at AFIT Scholar. It has been accepted for inclusion in Theses and Dissertations by an authorized administrator of AFIT Scholar. For more information, please contact [richard.mansfield@afit.edu](mailto:richard.mansfield@afit.edu).



**A PROPER SPLITTING THEATER DISTRIBUTION MODEL FOR  
IMPROVING FORCE FLOW ANALYSIS**

THESIS

Charles M Flores, Major, USA

AFIT-ENS-14-M-07

**DEPARTMENT OF THE AIR FORCE  
AIR UNIVERSITY**

**AIR FORCE INSTITUTE OF TECHNOLOGY**

---

---

**Wright-Patterson Air Force Base, Ohio**

**DISTRIBUTION STATEMENT A.**  
APPROVED FOR PUBLIC RELEASE; DISTRIBUTION UNLIMITED.

The views expressed in this thesis are those of the author and do not reflect the official policy or position of the United States Air Force, Department of Defense, or the United States Government. This material is declared a work of the U.S. Government and is not subject to copyright protection in the United States.

AFIT-ENS-14-M-07

**A PROPER SPLITTING THEATER DISTRIBUTION MODEL FOR  
IMPROVING FORCE FLOW ANALYSIS**

THESIS

Presented to the Faculty

Department of Operational Sciences

Graduate School of Engineering and Management

Air Force Institute of Technology

Air University

Air Education and Training Command

In Partial Fulfillment of the Requirements for the  
Degree of Master of Science in Operations Research

Charles M. Flores, BS

Major, USA

March 2014

**DISTRIBUTION STATEMENT A.**  
APPROVED FOR PUBLIC RELEASE; DISTRIBUTION UNLIMITED.

AFIT-ENS-14-M-07

**A PROPER SPLITTING THEATER DISTRIBUTION MODEL FOR  
IMPROVING FORCE FLOW ANALYSIS**

Charles M. Flores, BS

Major, USA

Approved:

\_\_\_\_\_  
//signed//  
Jeffery D. Weir, PhD (Advisor)

14 March 2014  
Date

\_\_\_\_\_  
//signed//  
Raymond R. Hill, PhD (Reader)

14 March 2014  
Date

### **Abstract**

United States Transportation Command (USTRANSCOM) force flow analysts perform the daunting task of determining feasibility of vehicle mixtures that will support theater distribution. Analysts conduct sensitivity analysis on the vehicle mixture solution to determine proper feasibility. Their current tool, the Improved Theater Distribution Model (ITDM) uses a multimodal, mixed set of vehicles to model the pickup and delivery of a set of requirements within a given time window. Although, the model is a sufficient tool, it may provide incorrect feasible solutions, which in turn may lead to an improper vehicle mixture for a set of given requirements.

Improving upon the ITDM, a Properly Splitting Theater Distribution Model (PSTDM) was created. The PSTDM, like the ITDM, is a mixed integer programming model that allocates specific vehicle types to deliver requirements in a way that minimizes cost and late deliveries.

The PSTDM improves upon the ITDM solutions by taking into account and identifying oversized/outsized equipment, preventing improper splitting of requirements and matching vehicles capabilities within requirement demands. The new set of solutions provides analysts the necessary insight on vehicle combinations that provide proper feasible pickup and deliveries.

To my wife who was supportive of the long hours away from home. I love you and blessed to have you in my life. To my parents thank you for giving me the latitude to pursue my own interest and instilling my morals. To my Brother, I love you and thank you very much for showing me what is really important in life. Finally, to my sister who embodies the true meaning of the strong will survive, I love you.

## **Acknowledgments**

I would like to express my sincere appreciation to my faculty advisor, Dr. Jeffery Weir, for his guidance and support throughout the course of this thesis effort. The insight, experience and motivation were absolutely instrumental to the completion of this thesis. I would also like to thank my sponsor, Josh M Kovich, from Military Surface Deployment and Distribution Command for both the support and latitude provided to me and AFIT throughout this project.

Charles M. Flores



## Table of Contents

Abstract .....	iv
Table of Contents .....	vii
List of Figures .....	ix
List of Tables .....	xi
I. Introduction .....	1
Background.....	<b>Error! Bookmark not defined.</b>
Problem Statement.....	4
Research Objectives/Questions/Hypotheses .....	6
II. Literature Review .....	9
Description .....	9
Relevant Research .....	10
Pickup and Delivery Problems with Split Loads.....	11
Special ordered Sets .....	15
Theater Distribution Model .....	16
Conclusion.....	22
III. Methodology .....	24
Chapter Overview.....	24
TDM Issues. ....	24
RTDM.....	26
RTDM Conclusion .....	32
Assumptions .....	33
ITDM Introduction .....	34
ITDM Conclusion.....	41

PSTDM Introduction .....	42
Assumptions of PSTDM.....	42
PSTDM Overview .....	45
PSTDM Summary .....	51
IV. Analysis and Results.....	53
Chapter Overview.....	53
Model Testing.....	53
Test Case 1 .....	55
Test Case 2 .....	60
Test Case 3 .....	63
Validation and Verification.....	65
Summary.....	66
V. Conclusions and Recommendations .....	68
Chapter Overview.....	68
Recommendations for Future Research.....	69
Appendix A. LINGO 11 Settings.....	72
Appendix B. TPFDD and Full Solution for Test Cases.....	72
Appendix C. PSTDM Code .....	74
Bibliography .....	75
Vita .....	76

## List of Figures.

Figure 1. Solution of Bad Split .....	5
Figure 2. Example of Split load benefits (Nowak, 2005) .....	14
Figure 3. Simple Example Set .....	25
Figure 4. Example of TPFDD Oversize Problem .....	42
Figure 5. Level 4 Example of Oversize .....	43
Figure 6. Example of Oversize Solution.....	43
Figure 7. Picture of Z40439 .....	43
Figure 8. Example of Level 4 Data.....	45
Figure 9. PSTDM Small Solution w/Rail .....	56
Figure 10. Test Case 1 Avg. Payload & Daily Cost .....	56
Figure 11. TPFDD for Test Case 1 .....	57
Figure 12. Test Case 1 Results.....	58
Figure 13. Statistics from Test Case 1 .....	58
Figure 14. Example of Bulk Distribution .....	58
Figure 15. Requirement 26 in TPFDD.....	59
Figure 16. Case 1 Solution for ITDM.....	59
Figure 17. Case 1 Solution for PSTDM.....	60
Figure 18. Test Case 2 Results.....	61
Figure 19. Test Case 2 Results.....	62
Figure 20. Test Case 2 Statistics .....	62
Figure 21. Test Case 3 Results.....	64

Figure 22. Test Case 3 Statistics ..... 65

## List of Tables

Table 1. TDM Sets .....	19
Table 2. TDM Parameters.....	20
Table 3. TDM Decision Variables .....	20
Table 4. RTDM Basic Sets .....	30
Table 5. RTDM Function Derived Sets .....	30
Table 6. RTDM Parameters .....	31
Table 7. RTDM Decision Variables .....	31
Table 8. ITDM Basic Set .....	37
Table 9. ITDM Function Sets .....	38
Table 10. ITDM Parameters .....	39
Table 11. ITDM Decision Variables.....	39
Table 12. PSTDM Basic Set .....	48
Table 13. PSTDM Function Derived Sets .....	49
Table 14. PSTDM Parameters .....	50
Table 15. ITDM Decision Variables.....	50

# **A PROPER SPLITTING THEATER DISTRIBUTION MODEL FOR IMPROVING THEATER DISTRIBUTION FORCE FLOW ANALYSIS**

## **I. Introduction**

The Nation's ability to project and sustain military power depends on the effectiveness of joint logistics. Joint logistics delivers sustained logistic readiness for the combatant commander (CCDR) and subordinate joint force commanders (JFCs) through the integration of national, multinational, service, and combat support agency capabilities. The synchronization of these capabilities ensures forces are physically available and properly equipped, at the right place and time, to support the force (Joint Chiefs of Staff, Joint Logistics, Joint Publication 4-0, 2008). Since joint logistics affects all military components and is one of the Department of Defense's (DOD's) most important roles there is a lot of planning to make sure that the CCDR request for equipment and goods can be delivered, and delivered on time.

There are many phases and steps in the DOD distribution process. One of the overarching distribution plans is called the Global Distribution process. The Global distribution process coordinates and synchronizes fulfillment of joint force requirements from points of origin to points of employment (Joint Chiefs of Staff, Joint Logistics, Joint Publication 4-0, 2008). Within global distribution, there are three major legs and each are planned in order to meet the objectives of the Joint Chiefs of Staff and the CCDR. The first leg is the intercontinental leg, which entails the movement from the deploying forces home station to the port of embarkation (POE). Next is the inter-theater leg, which is the movement from POE to the port of debarkation (POD). Lastly is the intra-theater movement, this is a movement from POD to point of need or final destination. This last

leg is where a majority of the research will focus in order to provide planners a better tool to properly assess this difficult movement.

“Distribution includes the ability to plan and execute the movement of forces for deployment and redeployment....” and the organization that has a preponderance of the responsibility of this distribution process is the United States Transportation Command (USTRANSCOM) (Joint Chiefs of Staff, Distribution Operations, Joint Publication 4-09, 2010). Some of USTRANSCOM’s responsibilities include, but are not limited to, “serve as the DOD single manager for transportation responsible for providing common-user and commercial air, land and sea transportation”(Joint Chiefs of Staff, Joint Logistics, Joint Publication 4-0, 2008). Since USTRANSCOM is a large proponent in planning and overseeing the transportation of DOD assets, it is apparent that the organization has been challenged as military forces are deploying more frequently to austere and overseas locations that have primitive transportation systems. Therefore, USTRANSCOM’s timeline for planning has become so shortened that planners and analyst do not have sufficient time to conduct the thorough repetitive processes that accompanies planning large movements.

USTRANSCOM periodically holds force flow conferences where they analyze the three phases of the Global Transportation and determine feasibility of moving equipment in accordance with an Operations Plan (OPLAN). When equipment must move with the forces in an OPLAN a Time Phased Force Deployment Data (TPFDD) sheet accompanies the OPLAN. The submitting unit brings both documents to the force flow planning session as both rely on each other. On the TPFDD details about the

equipment are listed to include where, when and what must be moved in order to accomplish the OPLAN and help give the CCDR all the assets he needs on a deployment.

As the first two phases do hold challenges of their own, the most challenging phase is the theater distribution; specifically early in the operation because the volume of material flowing into theater can overwhelm the infrastructure and transportation capabilities of the host nation (Longhorn & Kovich, 2012). In 2012 analyst and planners at USTRANSCOM used brute force techniques in order to determine feasibility of a transportation plan imbedded in an OPLAN to meet the requirements of a TPFDD. USTRANSCOM planners would also try and use simulation tools to analyze the feasibility of the plan. Unfortunately, the simulation tools would only produce the limitations of the plan and not recommend any operable solutions. The analyst and planner would conduct an iterative process to match transportation requirements put forth by CCDR within the TPFDD with viable assets on ground in the host country to determine if a transportation plan was viable. As this technique works, it is hard to produce results in a timely manner. Also, a large downfall in this process is that any changes or sensitivity analysis would lead to more iterations, and obviously more precious time. Therefore, to help this process, 2LT Micah J. Hafich, in 2012-2013, created a mixed integer programming model called the Theater Distribution Model (TDM) to help improve theater distribution analysis. The TDM was formulated by the Longhorn & Kovich paper of 2012 and was the first model to be created. Consequently two other models would be created; Reduced Theater Distribution Model (RTDM) and



the Improved Theater Distribution Model (ITDM). All three models will be discussed in later chapters.

Hafich's ITDM was very insightful to analysts at USTRANSCOM as they would no longer have to use the iterative process to determine the feasibility of a plan. The model receives the constraints and materials from the (TPFDD) then determines the most cost efficient way to move material into theater given the constraints of cost, time and modes of transportation. This allows for analysts conducting sensitivity analysis on an OPLAN to quickly determine feasibility of a TPFDD. As good as this model currently is there are certain features that can be improved to help provide a more realistic model and in turn help provide better solutions for the planners at USTRANSCOM.

### **Problem Statement**

This research will improve the mixed integer model currently used at USTRANSCOM to analyze theater distribution. Their current ITDM gives a feasibility solution based on liquid short tons of material and splits these requirements as many times as necessary in order to minimize cost and lateness. In order to meet the OPLAN timeline the solution gives how many vehicles are needed to move a specific TPFDD. The program will determine how many short tons can be moved by a specific mode of transportation then split the short tons into the most economical loads. The split that the model produces can be an incorrect solution as the program doesn't take into account what the requirements really are. Figure 1 is an example of a solution of the ITDM with only two requirements. Requirement 1 was a 22.4 ton M939 truck and the second was

14.4 ton M35 truck. There are two problems with this solution that need to be solved. One problem is that Requirement 1 is split across three vehicles and Requirement 2 is split across two vehicles, which is illogical. Secondly, the Requirement 1 is split and moves at two different time periods. These particular loads cannot be split as indicated by the model, and must be identified and put onto a vehicle that can carry that specific requirement.

Number of Vehicles	Type	POE	POD	Day leaving	Tons Moved	Requirement number
2	M35	KUHE	KUHA	Day 36	16.00	1
1	M1083	KUHE	KUHA	Day 46	4.8	1
1	M35	KUHE	KUHA	Day 46	1.6	1
2	M35	KUHE	KUHA	Day 46	14.4	2

**Figure 1. Solution of Bad Split**

The first objective of this research is to properly determine what loads on a TPFDD can be split. It will identify key features in the TPFDD that help determine if loads can or cannot be split and then match that load with a vehicle capable of carrying that load

Secondly, this research will identify equipment that is oversized and oversized. Using Level 4 data used to create the TPFDD the model determines which equipment meet the criteria of oversize and oversized and ensures the cargo is loaded on properly sized transportation assets.

Lastly, this research will examine how to prevent split loads from traveling on multiple vehicles. Requirements that are split onto multiple vehicles as shown in Figure 1 are illogical and unreasonable. The model will have to use data from the TPFDD and split only viable requirements.

### **Research Objectives/Questions/Hypotheses**

The purpose of this research will be to improve the force flow planning capabilities at USTRANSCOM. Before the Improved Theater Distribution Model (ITDM), USATRANSCOM analysts used methods that took hours to days to provide answers on whether a TPFDD was valid or not. A valid solution is a solution in which all equipment would arrive at its final destination no later than a specific date provided by a combatant commander, called the Commanders Required Delivery Date (CRD). Fortunately, with the creation of the ITDM the analyst process for determining a solution was streamlined and improved to take minutes to determine feasibility of a proposed TPFDD. Since the timeline was so long with the legacy handwritten way it also didn't allow analysts to conduct proper sensitivity analysis, which now can be done in a much shorter timeline.

The model isn't expected to be 100% accurate as attempting to model all variability's of large scale movements can be overwhelming and complicated, and never accurately replicated. Conversely, when the model is calculating only a few movements there should be minimal error on the solution. Smaller solutions show how the

assumption of the ITDM can impact the true number of assets needed in order to produce a valid solution.

Since analysts at USATRANSCOM typically are planning on transporting millions of short tons in thousands of movements, it becomes obvious how the problem can escalate with more requirements.

The first objective of this research is to determine what loads within the TPFDD can be split. A typical TPFDD for a major OPPLAN can have thousands of movements with hundreds of thousands of short tons to be moved. The key is to identify which requirements within each line on the TPFDD are able to be split and which requirements cannot.

The second objective is to determine how much of a load will fill each vehicle. The current ITDM does not take into account dimensions, only short tons. If something is oversized or outsized it may or may not fit on the vehicle that the model suggests. I want to be able to identify this equipment and then make sure it is loaded on a vehicle that has been designated as an oversized/outsized capacity vehicle. This problem with outsized and oversized will greatly impact how equipment is moved into theater and how many of different types of vehicles are needed.

The last objective will make sure that the requirements are not split over many vehicles as shown in Figure 1. Keeping requirements together will help provide a more realistic answer and impact the number and type of vehicles needed for the TPFDD movement.

The model, given all modifications discussed, will provide a better solution to theater distribution problem. Better, in this case, might not be a faster calculation than the ITDM or not even lower cost (objective value). Instead the goal is to produce and more reasonable and realistic answer. My hypothesis is that the new model will produce solutions with a smaller amount of vehicles predicted than the current ITDM being used. I believe the model will also utilize more air vehicles as well, compared to the ITDM, and have a larger objective value.

## **II. Literature Review**

This chapter will review literature that deals with both split load deliveries with time windows and various distribution models.

### **Description**

This section will focus on showing the background on why the model was created and some of the work that led to its creation. This section will also explore research conducted that may help contribute to making the IDTM better. Although the research that is discussed in this section does not completely cover all relevant research in the area it will provide a general insight on the problems and efforts that have been overcome and applied in theater distribution-related models.

The military has many different models to help planners and leaders decide on military logistics. Military operations are conducted in a complex, interconnected, and global operational environment characterized by uncertainty (Joint Chiefs of Staff, Distribution Operations, Joint Publication 4-09, 2010). Models and decision support systems (DSS) are used to help overcome some uncertainty and provide insight on how to plan for these obstacles. As discussed in the Longhorn & Kovich (2012) paper, many of the models that the military uses are for day to day operations or are too narrow and unsuitable for force flow transportation feasibility analysis. In force flow analysis, planners were only looking at the feasibility of a plan and not necessarily the optimization of routes or vehicle specific movements. Instead, the force flow planners are

looking to determine how many vehicles are needed to transport cargo from a POD to a destination in a particular time window. As stated by the Joint Pub 4-09, military operations always have a level of uncertainty and since the enemy has a vote in the mission, occasionally the optimal solution is not the best solution for the movement of equipment and personnel.

### **Relevant Research**

Since there are multiple tools and models to help planners, the following research explored a few of the models and tools. A logistical planning tool was created that explores the effective and efficient strategies for tactical logistic distribution using an algorithm based on column and cut technique using Gomory –Chvatal rank-1 cuts. The basis behind this research was to minimize the cost of the supplying of military forces with needed commodities. The Canadian military is small compared to other world militaries and wanted to try and optimize the loading of their transportation assets in vehicle type and route used. The technique used tradeoffs between cost, lead-time and the safety of the routes to create an integer solution for the optimal fleet mix of the transportation assets to meet the demand of the end-users quality of service. Simply put, the paper created quality of service as a variable to meet the demand and expectations of the user based on multiple factors like lead time and reliability of transportation assets. After the fleet mixture was optimized, the next step would be to optimize the routes used by the transportation assets. This model finds the proper mix of equipment which is

applicable for force flow analysis, but then the model finds the best route which is not the purpose of force flow analysis (S.Sebbah, 2011).

The model uses both air and ground assets to accomplish the movements, but Rosenthal et al only takes into account airlift in their models. In their paper, they discuss a model called NRMO (NPS/RAND Mobility Optimizer) which optimizes routes, cargo and people through a transportation network with a given set of aircraft (Baker, 1999). The issues with these two theater distribution models are that they are too narrow and don't provide the generalization that a force flow planner needs. A force flow planner needs to assess the feasibility of a plan given a set of requirements. Unfortunately, both of these models are concerned with vehicle specific issues and do not provide the needed coverage for large scale planning purposes. Also, these don't model anything other than air assets. Although both models do a good job modeling air assets, this research is concerned with ground and air assets.

### **Pickup and Delivery Problems with Split Loads**

The problem being solved in this research is closely related to the pickup and delivery problem with split loads (PDPSL). It is obvious that vehicles used for deliveries that are not filled to capacity are not maximizing their ability to transport materials and therefore are not optimum. The split delivery problem tries to optimize vehicle routes and utilization by allowing more than one vehicle to service a requirement. Another way of thinking of this problem is a relaxation of the Vehicle Routing problem (VRP) where the vehicle is not restricted to visiting only one location. Research has shown that allowing split deliveries provide significant savings when discussing distance and number of



vehicles (Moshe Dror, 1989). The current ITDM allows a vehicle to split a requirement but it will not allow a vehicle to visit two final destinations. In other words, we can maximize vehicle cargo capacity as long as the two requirements have the same final destination. Although this works well in this particular model, force flow analysis requirements must be split realistically.

A more realistic split delivery scheduling problem was created in the mid 1990's. Research conducted proposed three heuristics to help improve routes based on different priorities. Since a large portion of final cost of product is tied in with its distribution cost, it makes sense to try and reduce this cost by minimizing routes (Giffin, 1995). Their heuristics included normal requirements of time windows and customers able to be serviced by more than one vehicle as you would expect from a PDPSL. The difference between their heuristics and the force flow model is the time to make a delivery is dependent on the delivery size and admissibility of any split deliveries. Since their fleet of vehicles is a set number they find different ways to match vehicles with customers using their heuristic. The heuristic that was most interesting was the third heuristic. This particular heuristic attempted to both minimize distance travelled and maximize vehicle utilization. The authors accomplished this by not allowing vehicles to depart a POE until some predefined amount of the vehicles capacity is assigned (maximizing the amount of cargo on a vehicle). The issue with this idea is that it is difficult to predetermine a set capacity that vehicles must be filled to before departing a POE. The ITDM already uses the average tonnage a vehicle can carry as a maximum capacity because many different factors could limit what a vehicle performance could be. This technique would be more

effective if there is more supply than demand, but this is not always the case for military analysts where the priority of the load may take precedence over the efficiency of the mission. For example, what if an aircraft engine had to get to an airfield across the world in no more than 24 hours? Well the only viable option would be to fly this engine part but due to distance the smallest aircraft capable of making the trip would be C-17. The aircraft engine weight is a total of 8,000 lbs and if the mission is absolutely critical then that cargo may be the only cargo on an aircraft that has the capability to transport over 20 times that weight. Another issue with the last heuristic is equipment can move early in order meet the minimum capacity requirement. These early arrival requirements can have severe consequences for the owner of the equipment if the cargo arrives at a destination that possibly isn't secure by coalition forces or doesn't have personnel available to receive it. In either scenario, there is justification of not having a vehicle at a certain capacity and therefore this research will use the average capacity.

A method created by a doctoral student would first create a nonlinear program that would solve a PDPSL then convert the nonlinear program into a mixed integer program. The end result is similar to what this research is constructing by using a mixed integer program to solve a variation of a PDPSL. His problem was based on a how a trucking company can reduce their cost by using split deliveries. What he determined with his mixed integer program is that the most significant cost benefits are with split loads just above  $\frac{1}{2}$  of the vehicle capacity (Nowak, 2005). Looking at Figure 2 you could easily see in a small example the benefits of split load delivery. The model centralized around producing the best routes for a set of vehicles. He relaxed the Pickup and Delivery

problems allowing for a vehicle to conduct multiple stops and not limiting the load size. Their research was concerned with optimizing routes and utilization and it doesn't relate exactly to this research. Specifically, the author's method of conversion from a nonlinear to a mixed integer program used new variables to attain a value of zero or one depending on if a vehicle had already visited a destination. The method then separates the constraints to keep linearity and then make an additional 19 constraints. Intuitively, in this research adding extra constraints and variables in a mixed integer program would only add additional time to the program trying to solve a model. Consulting with Dr. Weir, he suggested investigating special ordered sets.

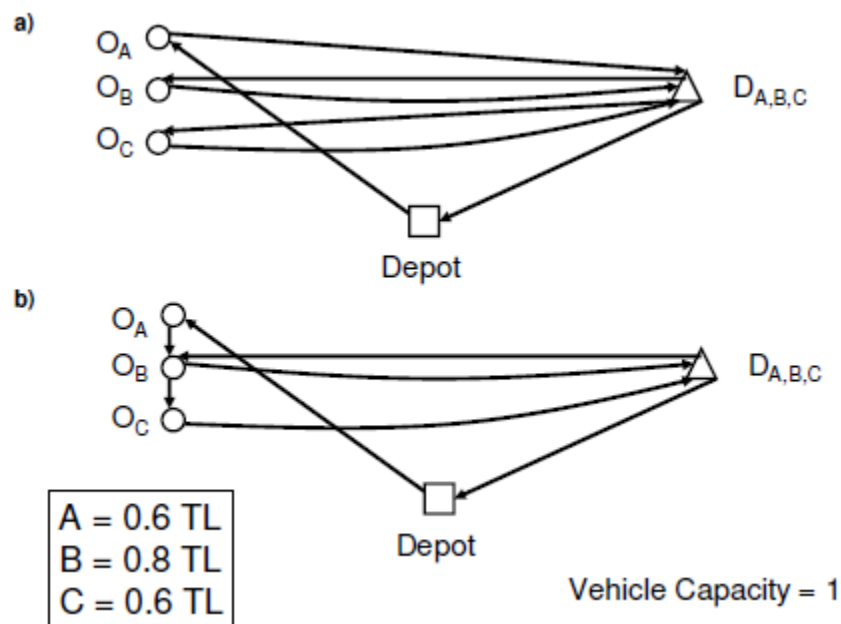

**Figure 2. Example of Split load benefits (Nowak, 2005)**

## Special ordered Sets

A popular method in creating an “either or” constraint in a linear model is to fashion binary variables. If this is done numerous times it becomes evident that this technique will create large sets of constraints that will evaluate to either 0 or 1. This is computationally inefficient and cumbersome to read in the model. Special orders Sets (SOS) of type one and two are concepts pioneered by Beale and Tomlin. This technique can be created for large sets where, in a group of variables, only one variable is desired to be selected and set to a value of one. Or alternatively, the problem could be looked at as a yes or no answer to a problem. Mathematically it looks like the following; let  $y_i$  denote a zero-one variable then

$$\sum_i y_i \leq 1 \quad (1)$$

is an example of SOS1 constraint or even more generally consider  $0 \leq x_i \leq u_i$  where  $u_i \in \mathbb{Z}$  which creates a constraint

$$\sum_i a_i x_i < b \quad (2)$$

where a and b are constants. Assuming (2) is strictly of the set of integers and all variables are non negative, you can assure that at most one of the  $x_i$  are nonzero (Bisschop, 2009). SOS2 is a set which at most two adjacent members of the set can be nonzero. These sets are normally used in non-linear functions of a variable in a linear model and are very helpful in finding global optimum solutions to problems containing

piecewise linear approximations to a nonlinear function. This research does not require any SOS2 type sets.

### **Theater Distribution Model**

The internal paper of Longhorn & Kovich (2012) proposed an integer programming model that minimizes the transportation cost and occurrences of late deliveries to help facilitate force flow planning. Since USTRANSCOM is the proponent for all movements in the military they must help in planning a unit's move from home station to their final destination. Normally, the hardest part to plan in force flow analysis is the leg from POD to final destination. This seems intuitive as normally the POD is in a foreign country and there are many obstacles and variables that need to be taken into account in order to determine feasibility. The TDM would not only minimize cost but also establish a mixture of vehicles necessary to meet the demand of the system based on the minimum cost. Although, vehicle routing problems have been studied for a long time, most routing problems optimize or find feasible solutions to individual vehicle routes or day to day execution of theater distribution. However, this type of optimization is not useful for force flow planning. Therefore, the IP proposed in the Longhorn and Kovich paper (2012) optimizes theater distribution at the aggregate vehicle level (number of trucks, railcars and aircraft) using simplifying assumptions for average vehicle speeds, payloads and loading and unloading times (Longhorn & Kovich, 2012). Therefore, the TDM will answer questions such as when, where, what type, and how many vehicles are needed to execute the necessary theater distribution within the physical network constraints (Hafich, 2013).

In the TDM there are sets  $M$  of modes of transportation and  $K$  of vehicle types that will be included into the model. Individual vehicle types will be  $k \in K$  of a single Mode  $m$ . For example C-5 would be a specific vehicle of Type  $k$  and of Mode  $m$  (Air). There are also two parameters associated with Type  $k$ , first is the daily cost of utilizing the vehicle  $b_k$ . Now the cost has two uses, first is strictly a financial cost. Secondly, the cost could be used as penalty or analytical tool in order to ascertain the impact of different political or country specific issues in theater distribution. The second parameter is the average payload  $p_k$  (measured in short tons) of a vehicle of Type  $k$ .

Most Theater Distribution Models use the TPFDD for information about the cargo used in a model. A TPFDD will list  $n_{max}$  movement requirements. The list of  $n_{max}$  is then used in creating a set  $N$  which contains all movements  $N = \{1, \dots, n_{max}\}$ , and makes each movement unique for all movements in the TPFDD. Each movement  $n \in N$  in the TPFDD is unique and contains specific requirements for each movement; like port of debarkation (POD), final destination, earliest arrival date (EAD), required delivery data (RDD) and total weight in short tons. The set of PODs  $i \in I$  and destinations  $j \in J$  are all extracted from the TPFDD. Next, we let  $r_{nij}$  be the total weight in short tons for requirement  $n$  that is delivered from POD  $i$  to destination  $j$ . In this model, the short tons are assumed to be liquid tons and so the size and quantity of all requirements are ignored. Let  $o_{imv}$  be the maximum number of Mode  $m$  vehicles of Type  $k$  that can be outloaded at POD  $i$  on Day  $v$ . Also, let  $u_{imv}$  be the maximum number of Mode  $m$  vehicles of Type  $k$  that can be unloaded at POD  $i$  on Day  $v$ .

The parameter  $ad_n$  describes the day in which requirement  $n$  arrives as at the pre-described TPFDD POD. The model assumes that there is a one day lag from when the cargo arrives at the POD before it can depart to its final destination. What this mathematically translates too is that the first time a requirement can leave the POD is  $ad_n + 1$ . The TPFDDs required deliver date (RDD) is represented in the model as  $rd_n$  for each requirement  $n$ . Any requirement that arrives after the RDD, specified in the TPFDD is considered late by the model. Fortunately, the model does allow extra time for requirement  $n$  to be delivered late. This variable is written as  $qd_n$  which is the extension days passed the RDD that the requirement can be delivered, but with a penalty  $g$ . So this signifies that each requirement  $n$  must be picked up from the POD and delivered to the final destination within the given time window beginning at  $ad_n + 1$  and expiring at  $rd_n + qd_n$ . The set  $V$  is the set of days covering the earliest possible day of requirement delivery and the absolute latest possible delivery day based on the information given in the TPFDD.

The model will assume that each vehicle starts at a POD and travels to a destination and then returns to the POD in a single trip. An estimate of the number of these trips (cycles) a vehicle can make from a POD to destination in a single day is input into the model. The parameter  $w_{nijmk}$  is the estimate of cycles that can be complete by a vehicle of Type  $k$ , Mode  $m$  delivering requirement  $n$  from POD  $i$  to destination  $j$ .

The decision variable that is used in the TDM is  $x_{nijmkv}$ . This decision variable is the number of vehicles of Mode  $m$ , Type  $k$  that are required on Day  $v$  to deliver

requirement  $n$  from POD  $i$  to destination  $j$ . Reference Tables 1 – 3 for a summary of the sets, parameters, and decision variables discussed in the TDM (Hafich, 2013).

**Table 1. TDM Sets**

<b>Set</b>	<b>Description</b>
$I$	Set of all PODs $i$
$J$	Set of al Destinations $j$
$K$	Set of all vehicle Types $k$
$M$	Set of all vehicles Modes $m$
$N$	Set of all Movement Requirements $n$
$V$	Set of all possible delivery Days $v$



**Table 2. TDM Parameters**

<b>Parameter</b>	<b>Description</b>
$b_k$	Daily operating cost for Type $k$ vehicle
$p_k$	Average payload of Type $k$ vehicle
$r_{nij}$	Total weight (in short tons) of Requirement $n$ that must be delivered from POD $i$ to Destination $j$
$ad_n$	Day when Requirement $n$ arrives at its given POD
$rd_n$	The Required Delivery Date (RDD) at the given Destination for Requirement $n$
$qd_n$	Maximum allowable extension days beyond RDD in which the Requirement $n$ can be delivered late to a given destination (with penalty)
$g$	Late penalty per vehicle per day
$o_{imv}$	Maximum number of Mode $m$ vehicle that can be outloaded at POD $i$ on Day $v$
$u_{jmv}$	Maximum number of Mode $m$ vehicles that can unloaded at Destination $j$ on Day $v$
$w_{nijmk}$	Number of possible cycles in a day between POD $i$ and Destination $j$ via Mode $m$ , Type $k$ vehicle transporting Requirement $n$

**Table 3. TDM Decision Variables**

<b>Variable</b>	<b>Description</b>
$x_{nijmkv}$	Number of vehicles of Mode $m$ , Type $k$ that are required on Day $v$ to deliver Requirement $n$ from POD $i$ to Destination $j$

Longhorn and Kovich intended the TDM to be a pure Integer program and the parameters, variables, and sets are formulated that way. Model 1 shows the mathematical formulation that was suggested by the Longhorn & Kovich paper.

### Model 1. TDM Formulation 1

$$\text{minimize } \sum_N \sum_I \sum_J \sum_M \sum_K \left\{ \sum_{v=ad_n+1}^{rd_n+q_n} b_k x_{nijm kv} + \sum_{v=ad_n+1}^{rd_n+q_n} g(v - rd_n) x_{nijm kv} \right\}$$

Such than

$$\sum_M \sum_K \sum_{v=ad_n+1}^{rd_n+q_n} w_{nijmk} p_k x_{nijm kv} \geq r_{nij} \quad \forall n, \forall i, \forall j \quad (3)$$

$$\sum_N \sum_J \sum_K w_{nijmk} x_{nijm kv} \leq o_{imv} \quad \forall i, \forall m, \forall v \quad (4)$$

$$\sum_N \sum_I \sum_K w_{nijmk} x_{nijm kv} \leq u_{jmv} \quad \forall j, \forall m, \forall v \quad (5)$$

$$x_{nijm kv} \in \{0\} \cup \mathbb{Z}^+ \quad \forall i, \forall j, \forall k, \forall m, \forall n, \forall v \quad (6)$$

It is easy to see that the model has two objectives that it is trying to minimize. In the first summation, they are minimizing the cost of vehicles supplied to move the requirements from POD to Destination. The second summation minimizes the number of late vehicles and determines a late penalty by multiplying the number of late vehicles by a penalty times the number of days it was late. So if the requirement was late by 2 days it would be  $2 * g$ , the later the vehicle by days, the bigger the penalty. A late requirement is any vehicle that delivers a requirement on an extension day  $qd_n$  after the RDD.

Constraint (3) multiplies the number of cycles by payload then by the number of vehicles to make sure that the number of vehicles selected meets the demand necessary to deliver the total weight for the requirement  $n$  between the allowable delivery days. Constraints (4) (5) make sure that the number of vehicles that cycle through a POD and Destination

in a Day can be unloaded and loaded within the time period specified. Constraint (6) ensures the decisions variables are integers so the program doesn't have a fraction of a vehicle.

The TDM was specifically designed by Longhorn and Kovich to provide insight for force flow analysis conferences. The main feature of the model was to provide analysts a simple and faster solution on feasibility of vehicle mixtures that would accomplish the movement of military equipment provided by Military units' submitted TPFDDs. The TDM was a good model and was a large improvement over current methods being used by USTRANSCOM force flow analysts, but as will be discussed in the Improved Theater Distribution Model (ITDM) there were flaws in the formulation that could provide solutions that the analyst didn't intend.

## **Conclusion**

The models and methods discussed in this chapter were just a glimpse of what has been done in the field of Theater Transportation modeling, pickup and delivery problem with split loads, and vehicle routing problems. Unfortunately, most of the research done in these areas is too specific for the requirements of USTRANSCOM force flow analysis. Instead of a model looking at feasibility, most of the models discussed in this chapter had high fidelity in route creation and load configuration, which is not the goal of the force flow analyst. Thus, the TDM was created with this vision in mind and hence why it does not take into account optimizing routes and instead assumes that the vehicle will travel from POD to Destination. Vehicle specific optimization is harder to accomplish and has more errors when trying to accomplish at such a high level necessary for force flow

analysts. Many of the factors affecting vehicle specific route optimization are not known or important at the force flow conferences at USTRANSCOM. Cycles are estimates because travel times vary due to road conditions, airport capabilities and rail accessibility, allowing this variable to be changed is a great tool for analysts. Therefore, letting the analyst have a say in the number of cycles a vehicle of Type  $k$  and of Mode  $m$  can travel from POD to Destination in a single day is very helpful when conducting feasibility of the TPFDD and also when conducting sensitivity analysis.

In most of the models discussed in this chapter the vehicles were predetermined with type and quantities when creating the model. Unfortunately, USTRANSCOM force flow analysts do not have this luxury and type and vehicle quantity is part of what the planners and USTRANSCOM must determine. The TDM takes into account the need to have both vehicle mixture and number of vehicles as variables in the mode. Using these two variables the model determines the optimal mixture of vehicles to meet the need to deliver the requirements at a minimum cost.

The TDM was a start to creating the model needed by USTRANCOM analysts to better conduct force flow analysis, but falls short in quality of solutions and assumptions. The methodologies proposed in this thesis are targeted at improving the assumptions and adding a touch of realism when splitting loads, making the solutions provided by the model more realistic solutions for force flow analysts.

### III. Methodology

#### Chapter Overview

The purpose of this chapter is to provide understanding on the techniques used in the ITDM to help improve the assumption and splitting of requirements and provide more realistic solutions. This chapter first outlines issues with the TDM and then discusses the ITDM created by 2LT Micah Hafich, because many of his assumptions and techniques are still used in the Properly Splitting Theater Distribution Model (PSTDM). Then, the chapter identifies the differences between Hafich's work and assumptions and ideas that are used in the PSTDM, and discusses the modification of the ITDM into the PSTDM.

#### TDM Issues.

The TDM was the first attempt at a model to help force flow analysts, but the model had issues that needed to be addressed. The goal of the TDM is to provide feasible vehicle combinations that would deliver TPFDD required cargo to their final destination based upon outload and unload constraints for both POD and destination at a minimum cost. The model accomplished the initial goal for small problems, but TPFDD's are normally thousands of requirements with multiple PODs and destinations. Since the model was a pure integer problem it was also computationally expensive for larger problems. The TDM would also create additional variables that weren't feasible or useful, making the problem even larger than needed. Mathematically, since the TDM objective function sums across  $N$ ,  $I$ ,  $J$ ,  $K$ , and some parts of  $V$ , the decision variable  $x_{nijmkv}$  is created for every possible combination of indices  $(n, i, j, m, k,)$  with some

parts of  $v$  as indicated above (Hafich, 2013). For example, let's look at the problem presented in Figure 3. Assume that Day 5 is within the delivery window for Requirement 1. The TDM will then try to enumerate all possibilities for this simple problem and create a variable that will be evaluated as  $(I, X, R, Rail, C-5, 5)$ . The decision variable named  $x_{(I, X, R, Rail, C-5, 5)}$  is not a realistic decision variable for Mode Rail, since vehicle of Type C-5 is an air vehicle. The TDM will evaluate each one of these illogical decision variables as zero as there will never be cycles of Mode Rail and C-5.

N	=	{1, 2, 3, 4}
I	=	{X, Y}
J	=	{R, S}
M	=	{Air, Road, Rail}
K	=	{C-5, M35}
V	=	{4, 5, 6, 7}

**Figure 3. Simple Example Set**

We can also see extraneous constraints are created as well. Looking at the first constraint (3) and assuming we move 50 short tons for requirement 1 from  $X$  to  $R$  or  $r_{1,X,R} = 50$ . Since we know that Requirement 1 only goes from  $X$  to  $R$  then  $r_{1,X,S} = r_{1,Y,R} = r_{1,Y,S} = 0$ . This makes sense and it is easy to see that these constraints should not be created, but the program will create the following constraints for equation (3).

$$\sum_M \sum_K \sum_{v=ad_n+1}^{rd_n+q_n} w_{nijmk} p_k x_{nijmkv} \geq 100 \quad n = 1, i = X, j = R \quad (6)$$

$$\sum_M \sum_K \sum_{v=ad_n+1}^{rd_n+q_n} w_{nijmk} p_k x_{nijmkv} \geq 0 \quad n = 1, i = X, j = S \quad (7)$$

$$\sum_M \sum_K \sum_{v=ad_n+1}^{rd_n+q_n} w_{nijmk} p_k x_{nijmkv} \geq 0 \quad n = 1, i = Y, j = R \quad (8)$$

$$\sum_M \sum_K \sum_{v=ad_n+1}^{rd_n+q_n} w_{nijmk} p_k x_{nijmkv} \geq 0 \quad n = 1, i = Y, j = S \quad (9)$$

Obviously equations (7), (8), (9) will always be at equality as  $w_{nijmk} = 0$  as there are no cycles between that particular POD  $i$ , Destination  $j$  for requirement  $n$ . Examining (4) and (5) simultaneously, due to their relationship to each other, we can see the same issue arise again. Once more, we note that not every combination of  $i, m, v$  and  $o, m, v$  are valid and therefore we would not sum overall vehicle  $k$  but only those vehicle  $k$  that a valid mode. Using the same example from above, the following two equations would be generated.

$$\sum_N \sum_J \sum_K w_{nijmk} x_{nijmkv} \leq 25 \quad i = X, v = 5 \quad (10)$$

$$\sum_N \sum_I \sum_K w_{nijmk} x_{nijmkv} \leq 25 \quad j = R, v = 5 \quad (11)$$

The decision variable will only evaluate to nonzero values when the POD  $i$  and Destination  $j$  are valid. Hence, the only equations that will be used by the model are (10) and (11) and all others created will be unnecessary.

## RTDM

In order to solve these issues, along with other details not thoroughly discussed, another model was created. The Reduced Theater Distribution Model (RTDM) reduced the unnecessary amount of extra constraints and decision variables. In order to reduce extra constraints, decomposing sets and binary functions are implemented which are used

to determine which portions of a set to sum through, as well as which constraints are valid and necessary constraints to include in the model (Hafich, 2013).

The RTDM didn't change parameters or decision variables from the TDM but instead it created sets to remove unwanted constraints and decision variables. Four decomposition sets were added to the RDM that are just modifications or additions to three of the original sets of M, K, and N. The first new set is  $M_{ij}$ , which is the set of all Modes  $m$  that have a valid route between POD  $i$  and Destination  $j$ . For example, if Air and Rail are possible transportation modes between a POD  $i$  and Destination  $j$ , but Road is not, then  $M = \{Air, Road, Rail\}$  and  $M_{ij} = \{Air, Rail\}$ . Set  $K_m$  is the set of all vehicles of Type  $k$  which are of Mode  $m$ . An example of  $K_m$  is if  $K = \{C-5, C-130, M135, M998\}$  then  $K_{Air} = \{C-5, C-130\}$ , preventing the Mode Rail of Type C-5 as described earlier. Next, the problem with the constraint variables had to be solved. New sets of  $N_i$  and  $N_j$  are the set of movement Requirements  $n$  that depart from POD  $i$  and arrive at Destination  $j$  respectively. These two sets then will only have valid sets of POD's and Destinations. These two sets are used in solving the problem of creating only valid constraints and eliminating unnecessary routes for the model.

Five function derived sets are also introduced. The sets are valid unload ( $VU$ ), valid outload ( $VO$ ), valid routes ( $VR$ ), valid on time movement ( $VTOM$ ) and valid late movement ( $VLM$ ). These sets are derived by evaluating six binary variables to help determine which parameters and constraints should be included in the model. The derived



sets will also work in conjunction with the new basic sets to determine which constraints and decision variables are valid. The following are the new binary functions:

$$A(n, v) = \begin{cases} 1, \text{if Requirement } n \text{ delivered on Day } v \text{ would be on time} \\ 0, \text{ otherwise} \end{cases} \quad (12)$$

$$B(n, v) = \begin{cases} 1, \text{if Requirement } n \text{ delivered on Day } v \text{ would be late} \\ 0, \text{ otherwise} \end{cases} \quad (13)$$

$$C(m, k) = \begin{cases} 1, \text{if vehicle of Type } k \text{ is also a Mode } m \text{ vehicle} \\ 0, \text{ otherwise} \end{cases} \quad (14)$$

$$D(n, i, j) = \begin{cases} 1, \text{if Requirement } n \text{ is to be delivered from POD } i \text{ to Destination } j \\ 0, \text{ otherwise} \end{cases} \quad (15)$$

$$E(i, m, v) = \begin{cases} 1, \text{if } \exists \text{ some Requirement } n \text{ that may outload at POD } i \text{ onto Mode } m \\ \text{vehicle on day } v \\ 0, \text{ otherwise} \end{cases} \quad (16)$$

$$F(i, m, v) = \begin{cases} 1, \text{if } \exists \text{ some Requirement } n \text{ that may outload at Destination } j \text{ off a} \\ \text{Mode } m \text{ vehicle on day } v \\ 0, \text{ otherwise} \end{cases} \quad (17)$$

The sets  $VR$ ,  $VO$ ,  $VU$  are the three new sets that will eliminate all of the additional constraints. The set  $VR = \{(n, i, j) \mid D(n, i, j) = 1\}$  enforces that a requirement  $n$  can only have one POD  $i$  and Destination  $j$ . Equation (15) will determine which one of the combinations of POD  $i$  and Destination  $j$ , are equal to one.

$VO = \{(i, m, v) \mid E(i, m, v) = 1\}$  uses the function in equation (16) to determine which

requirement may outload at a certain POD  $i$ , Mode  $m$  and Day  $v$ . Lastly,  $VU = \{(j, m, v) \mid F(j, m, v) = 1\}$  very similar to  $VO$ , uses the function (17) to determine which requirement may unload at a certain Destination  $j$ , Mode  $m$  and Day  $v$ . The set  $VLM$  relates the decision variables for Requirements  $n$  shipping from POD  $i$  to Destination  $j$  via Mode  $m$ , Type  $k$  on Day  $v$  such that  $rd_n < v \leq rd_n + qd_n$  (Hafich, 2013). This set describes the Requirements  $n$  that arrive at their destination after the RDD but before the end of the extension days  $qd_n$ .  $VLM = \{(n, i, j, k, m, v) \mid B(n, v) \cdot C(m, k) \cdot D(n, i, j) = 1\}$  uses function (13), (14) and (15) to determine which decision variables that arrive between the RDD and extension days but will not have Mode/Type mismatches, POD/Destination mismatches, or deliver prior to or on the RDD. The model keeps these decision variables and reports them as a late delivery in the solution.

The last set  $VOTM = \{(n, i, j, k, m, v) \mid A(n, v) \cdot C(m, k) \cdot D(n, i, j) = 1\}$ , describes a set of decision variables that represent the Requirements  $n$  that arrive at their Destination  $j$  before or on their required RDD date using functions (12), (14), (15). So mathematically put, Requirement  $n$  is eligible to be delivered from POD  $i$  to Destination  $j$  by Mode  $m$ , vehicle Type  $k$  on Day  $v$  where  $v \leq rd_n$  (Hafich, 2013). The reason for these functions to be discussed here is that the ITDM will use the same sets and they will not be described in later sections. Tables 4, 5, 6, and 7 will show the new RTDM Basic Sets, Derived Functions sets, Parameters and decision variables. Model 2 shows the mathematical representation of the decision variables and constraints as represented as a linear program.

**Table 4. RTDM Basic Sets**

<b>Set</b>	<b>Description</b>
$I$	Set of all PODs $i$
$J$	Set of al Destinations $j$
$K$	Set of all vehicle Types $k$
$M$	Set of all vehicles Modes $m$
$N$	Set of all Movement Requirements $n$
$V$	Set of all possible delivery Days $v$
$M_{ij}$	Set of all Modes $m$ with valid direct paths between POD $i$ and Destination $j$
$K_m$	Set of all vehicles of Type $k$ which are of Mode $m$
$N_i$	Set of movement Requirements $n$ that depart from POD $i$
$N_j$	Set of movement Requirements $n$ that arrive at Destination $j$

**Table 5. RTDM Function Derived Sets**

<b>Set</b>	<b>Description</b>	<b>Mathematical Notation</b>
VOTM	Valid On Time Movements	$\{(n, i, j, k, m, v \mid A(n, v) \cdot C(m, k) \cdot D(n, i, j) = 1\}$
VLM	Valid Late Movements	$\{(n, i, j, k, m, v \mid B(n, v) \cdot C(m, k) \cdot D(n, i, j) = 1\}$
VR	Valid Routes	$\{(n, i, j \mid D(n, i, j) = 1\}$
VO	Valid Outloading	$\{(i, m, v \mid E(i, m, v) = 1\}$
VU	Valid Unloading	$\{(j, m, v \mid F(j, m, v) = 1\}$

**Table 6. RTDM Parameters**

<b>Parameter</b>	<b>Description</b>
$b_k$	Daily operating cost for Type $k$ vehicle
$p_k$	Average payload of Type $k$ vehicle
$r_{nij}$	Total weight (in short tons) of Requirement $n$ that must be delivered from POD $i$ to Destination $j$
$ad_n$	Day when Requirement $n$ arrives at its given POD
$rd_n$	The Required Delivery Date (RDD) at the given Destination for Requirement $n$
$qd_n$	Maximum allowable extension days beyond RDD in which the Requirement $n$ can be delivered late to a given destination (with penalty)
$g$	Late penalty per vehicle per day
$o_{imv}$	Maximum number of Mode $m$ vehicle that can be outloaded at POD $I$ on Day $v$
$u_{jmv}$	Maximum number of Mode $m$ vehicles that can unloaded at Destination $j$ on Day $v$
$w_{nijmk}$	Number of possible cycles in a day between POD $i$ and Destination $j$ via Mode $m$ , Type $k$ vehicle transporting Requirement $n$

**Table 7. RTDM Decision Variables**

<b>Variable</b>	<b>Description</b>
$x_{nijmkv}$	Number of vehicles of Mode $m$ , Type $k$ that are required on Day $v$ to deliver Requirement $n$ from POD $i$ to Destination $j$

## Model 2. Reduced Theater Distribution Model1 (RTDM)

$$\text{Minimize} \quad \sum_{(n,i,j,m,k,v) \in VOTM \cup VLM} b_k x_{nijmkv} + \sum_{(n,i,j,m,k,v) \in VLM} g(v - rd_n) x_{nijmkv} \quad (18)$$

Subject to

$$\sum_{M_{ij}} \sum_{K_m} \sum_{v=ad_n+1}^{rd_n+q_n} w_{nijmk} P_k x_{nijmkv} \geq r_{nij} \quad \forall (n, i, j) \in VR \quad (19)$$

$$\sum_{N_i} \sum_J \sum_{K_m} w_{nijmk} x_{nijmkv} \leq o_{imv} \quad \forall (i, m, v) \in VO \quad (20)$$

$$\sum_{N_i} \sum_J \sum_{K_m} w_{nijmk} x_{nijmkv} \leq u_{jmv} \quad \forall (i, m, v) \in VU \quad (21)$$

$$x_{nijmkv} \in \{0\} \cup \mathbb{Z}^+ \quad \forall (n, i, j, m, k, v) \in VOTM \cup VLM \quad (22)$$

### RTDM Conclusion

The introduction of the new Functions and Decomposed sets greatly reduces the amount of constraints and decision variables that must be evaluated. The RTDM Model, Model 2, mimics Model 1 (TDM) where the real differences between the two are the introduction of the new sets and functions. The preprocessing of determining the illogical and unused constraints and decision variable greatly reduced the problem size to solve. This is very importation because the RTDM is still a pure integer model. The objective of the RTDM, Model 2, is to minimize both vehicle utilization cost and penalties for late deliveries which is exactly the same as the TDM. Now instead of enumerating all possibilities for objective functions and constraints, the new functions and derived sets limit the choices that are available for evaluation. Therefore, the

solution set produced by the RTDM will be the same as the TDM with the distinction seen only in the amount of time and size of the problem.

The heart of the RTDM is still a pure integer program which, when faced with a large problem or large TPFDDs, it may take a long time to solve. Also, after some quick analysis of the solutions produced by the RTDM, there is a need for some improvement. Each Requirement  $n$  is allocated to at least one vehicle dedicated to that requirement. Consequently, the formulation will not ensure the use of the full capacity of each vehicle by combining requirements. This leads to an inefficiency of not combining similar loads where both requirements have the same POD  $i$  and Destination  $j$  and similar arrival date at POD and same RDD. Inevitably, the solution constructed by the RTDM would lead to a lot of TPFDDs resulting in bad solutions based on the number of vehicles involved in transporting requirements into theater.

Another issue with the RTDM and TDM formulation is how lateness is represented. Lateness is penalized per vehicle per late day and this is not reasonable for a realistic solution. Looking at the problem simplistically, two vehicles would be penalized the same amount no matter how much cargo each vehicle carried. Or a single vehicle could carry both on time and late cargo but would still be penalized a single value. Fortunately, the ITDM corrects these issues with a new formulation, and will not allow on time cargo to be penalized.

### **Assumptions**

Before diving into the ITDM some of the basic assumptions need to be discussed. Many of the RTDM assumptions remain the same so only the differences will be

addressed. The new assumptions are flows: any vehicle can carry any part of a Requirement; vehicles can have both late and on time cargo onboard; vehicles mixtures are approximations on what will be needed to move the requirements, as real world factors of environment, transportation structures and security concerns are not addressed in the model (Hafich, 2013).

### **ITDM Introduction**

The ITDM modifies the decision variables, from evaluating vehicle requirements based on late and on time requirements, to modeling the flow of requirements based on short tons and then addressing the vehicles necessary to support the flow of tonnage. The ITDM uses some of the sets from the RTDM and develops a few new sets as well. The binary functions (12) – (17) are still used in the ITDM with an addition of a new binary function. The new function (23),  $G(i, j, v)$  establishes whether or not there exist any Requirement  $n \in N$ , from POD  $i$  to Destination  $j$ , that may be delivered, either on time or late, on Day  $v$  (Hafich, 2013).

$$G(i, j, v) = \begin{cases} 1, & \text{if } \exists \text{ some Requirement } n \text{ from POD } i \text{ to Destination } j \text{ s.t. } ad_{n+1} \leq v \leq rd_n + qd_n \\ 0, & \text{otherwise} \end{cases} \quad (22)$$

$G(i, j, v)$  (22) is an integral part of creating the new set of Valid Vehicles  $VV$ .  $VV = \{(i, j, m, k, v) | G(i, j, v) \cdot C(m, k) = 1\}$  will determine if there is a Requirement  $n$  that can be delivered between  $ad_n + 1 \leq v \leq rd_n + qd_n$ . The other function (14), like RTDM, determines that the vehicle of Mode  $m$  and Type  $k$  is valid. This set will be used to create a set of possible vehicle assignments for a Requirement  $n$ .

Another new set is the Valid Flows (*VF*) set. This set will identify a valid decision variable that represents both on time and late requirements. Mathematically, the set is equal to  $VF = \{(n, i, j, m, k, v) \mid A(n, v) \cdot C(m, k) \cdot D(n, i, j) + B(n, v) \cdot C(m, k) \cdot D(n, i, j) = 1\}$ . *VF* can be separated into two distinct pieces. One is function (12), (14) and (15) which determines if a requirement will arrive on time,  $ad_n + 1 \leq v \leq rd_n$  to POD *i* and Destination *j* with a valid vehicle of Type *k* of Mode *m*. The other is function (13), (14) and (15) will provide the late arriving  $rd_n < v \leq rd_n + qd_n$  vehicles to a POD *i* and Destination *j* with a valid vehicle of Type *k* of Mode *m*. Adding both parts together will mean we only receive a variable back when there is either a late arrival or an on time arrival for Requirement *n*.

The last function to be introduced is the Late Flow (*LF*). This is mathematically defined as the latter part of the *VF* function. Therefore, it will be defined as  $LF = \{(n, i, j, m, k, v) \mid B(n, v) \cdot C(m, k) \cdot D(n, i, j) = 1\}$ . *LF* will only identify the requirements that arrive late to their destination.

The ITDM inherits most of the RTDM parameters, but with two key changes. One is the cycle parameters. In the TDM and RTDM the parameter for cycle was represented as  $w_{ijmkv}$  which took into account the Requirement *n*. The cycle isn't dependent on the Requirement *n* as the cycle is just an estimate of the time and distance of a vehicle of Type *k*, of Mode *m* can travel from POD *i* to Destination *j*. Thus, by removing the Requirement *n* the meaning or value for the cycle has not changed but the restriction that a cycle be tied to a specific requirement is. The second change is to the



penalty parameter  $g$ . As discussed in the problems with the RTDM, the penalty function  $g$  is used to penalize a vehicle for every day late. However, in the ITDM the penalty function penalized each ton of material per day.

A change to the basic set is a new decomposing set  $N_{ijv}$ . This set encompasses all Requirements  $n \in N$  which are to be delivered from POD  $i$  to Destination  $j$  and are eligible to be delivered on Day  $v$  (Hafich, 2013). This will make sure that there are enough vehicles to satisfy the flow constraints since now both the decision variable and cycle do not have a relation to the requirement.

One of the most important changes to the ITDM compared to the RTDM was the objective function. Instead of having a pure integer program, the ITDM transforms to a mixed integer program. This non integer part of the model is accomplished by a new continuous decision variable  $y_{nijmkv}$ . This new variable represents the flow of requirements throughout the network. The new decision variable represents the number of short tons of Requirement  $n$  being delivered by Mode  $m$ , of vehicle Type  $k$  from POD  $i$  to Destination  $j$  on Day  $v$  (Hafich, 2013). The second change to the decision variable is to the integer part. In the TDM and RTDM we had  $x_{nijmkv}$  which, like the cycle, was tied to a Requirement  $n$ . These connections lead to unwanted results in the solutions, in particular each Requirement  $n$  being allocated to a single vehicle instead of combining requirements traveling to and from the same POD and Destination within an appropriate time. In order to remove the vehicle being tied to the requirement in the ITDM the decision variable had the Requirement  $n$  removed and the new decision variable is defined as  $x_{ijmkv}$ . The new

variable then represents the number of vehicles of Mode  $m$ , Type  $k$  needed on Day  $v$  to deliver requirements from POD  $i$  to Destination  $j$ . This change will allow late cargo and on time cargo to be on the same vehicle and because of the definition of the new penalty function, the on time cargo will not be penalized while the late cargo is. The addition of a continuous variable allows the model to permit requirements to be split and put onto separate vehicles to minimize the amount of late tonnage. The following tables and Model 3 will show the structure of the ITDM.

**Table 8. ITDM Basic Set**

<b>Set</b>	<b>Description</b>
$I$	Set of all PODs $i$
$J$	Set of al Destinations $j$
$K$	Set of all vehicle Types $k$
$M$	Set of all vehicles Modes $m$
$N$	Set of all Movement Requirements $n$
$V$	Set of all possible delivery Days $v$
$M_{ij}$	Set of all Modes $m$ with valid direct paths between POD $i$ and Destination $j$
$K_m$	Set of all vehicles of Type $k$ which are of Mode $m$
$N_{ijv}$	Set of Requirements $n$ that are eligible to deliver from POD $I$ to Destination $j$ on Day $v$

**Table 9. ITDM Function Sets**

<b>Set</b>	<b>Description</b>	<b>Mathematical Notation</b>
VV	Valid Vehicle	$\{(i, j, k, m, v \mid G(n, v) \cdot C(m, k) = 1\}$
VF	Valid Flows	$\{(n, i, j, k, m, v \mid A(n, v) \cdot C(m, k) \cdot D(n, i, j) + B(n, v) \cdot C(m, k) \cdot D(n, i, j) = 1\}$
LF	Late Flows	$\{(n, i, j, k, m, v \mid B(n, v) \cdot C(m, k) \cdot D(n, i, j) = 1\}$
VR	Valid Routes	$\{(n, i, j \mid D(n, i, j) = 1\}$
VO	Valid Outloading	$\{(i, m, v \mid E(i, m, v) = 1\}$
VU	Valid Unloading	$\{(j, m, v \mid F(j, m, v) = 1\}$

**Table 10. ITDM Parameters**

<b>Parameter</b>	<b>Description</b>
$b_k$	Daily operating cost for Type $k$ vehicle
$p_k$	Average payload of Type $k$ vehicle
$r_{nij}$	Total weight (in short tons) of Requirement $n$ that must be delivered from POD $i$ to Destination $j$
$ad_n$	Day when Requirement $n$ arrives at its given POD
$rd_n$	The Required Delivery Date (RDD) at the given Destination for Requirement $n$
$qd_n$	Maximum allowable extension days beyond RDD in which the Requirement $n$ can be delivered late to a given destination (with penalty)
$g$	Late penalty per short ton per day
$o_{imv}$	Maximum number of Mode $m$ vehicle that can be outloaded at POD $I$ on Day $v$
$u_{jmv}$	Maximum number of Mode $m$ vehicles that can unloaded at Destination $j$ on Day $v$
$w_{ijmk}$	Number of possible cycles in a day between POD $i$ and Destination $j$ via Mode $m$ , Type $k$ vehicle

**Table 11. ITDM Decision Variables**

<b>Variable</b>	<b>Description</b>
$x_{ijmkv}$	Number of vehicles of Mode $m$ , Type $k$ that are required on Day $v$ to deliver Requirement $n$ from POD $i$ to Destination $j$
$y_{nijmkv}$	Short tons of Requirement $n$ delivered from POD $i$ to Destination $j$ on Mode $m$ , Type $k$ vehicle on Day $v$

### Model 3. Improve Theater Distribution Model (ITDM)

$$\text{Minimize } \sum_{(i,j,m,k,v) \in VV} b_k x_{ijmkv} + \sum_{(n,i,j,m,k,v) \in LF} g(v - rd_n) y_{nijmkv} \quad (23)$$

Subject to

$$\sum_{M_{ij}} \sum_{K_m} \sum_{v=ad_n+1}^{rd_n+q_n} y_{nijmkv} = r_{nij} \quad \forall (n, i, j) \in VR \quad (24)$$

$$\sum_J \sum_{K_m} w_{ijmk} x_{ijmkv} \leq o_{imv} \quad \forall (i, m, v) \in VO \quad (25)$$

$$\sum_I \sum_{K_m} w_{ijmk} x_{ijmkv} \leq u_{jmv} \quad \forall (i, m, v) \in VU \quad (26)$$

$$\sum_{N_{jv}} y_{nijkmv} \leq x_{ijmkv} w_{ijmk} P_k \quad \forall (i, j, m, k, v) \in VV \quad (27)$$

$$x_{ijmkv} \in \{0\} \cup \mathbb{Z}^+ \quad \forall (i, j, m, k, v) \in VV \quad (28)$$

$$y_{nijmkv} \geq 0 \quad \forall (n, i, j, m, k, v) \in VF \quad (29)$$

The improvements of the ITDM over the RTDM and TDM are more than just a reduction in decision variables and constraints. In order to provide a more realistic solution, the objective function now will attempt to minimize vehicle cost and minimize the penalties linked to the short tons being delivered late. This is more realistic because the model will not necessarily minimize the number of late vehicles like in the RTDM and TDM. Instead, the model will minimize the number of late tons.

The other significant change for the ITDM was the flow variable  $y_{nijmkv}$ . This variable is very important in solving the problem of allocating a single vehicle for each

requirement. Now the model will allow a mixture of requirements, based on their short tons, to be allocated on a vehicle as long as they have the same POD and Destination. This makes the model more realistic as the objective is to minimize the cost and get the requirements' to their destinations on time.

The constraints for outload and unload have not changed from the RTDM to the ITDM. Both constraints are still concerned with the max number of vehicles to be processed at a POD  $i$  and Destination  $j$ .

The new constraint (24)  $\sum_{M_{ij}} \sum_{K_m} \sum_{v=ad_n+1}^{rd_n+q_n} y_{nijmkv} = r_{nij}$  ensures that the model accounts

for each requirement. The sum of all flow variables must equal the total amount of short tons for each requirement. This change was necessary to make sure that if requirements were split that the entire requirement would arrive at the prescribed Destination  $j$ . The linking constraint (27)  $\sum_{N_{jv}} y_{nijkmv} \leq x_{ijkmv} w_{ijmk} p_k$  makes sure that there is sufficient vehicle capacity to move the flow of the requirements.

### **ITDM Conclusion**

The implementation of the continuous flow variables, new constraints and decomposed sets help reduce the problem size and provide a better solution for force flow analysts. Unfortunately, there were some unintended consequences and assumptions that did hurt the realism of the model. One such consequence was that the flow variable isn't an integer, so it allows requirements to be split across multiple vehicles. As this isn't a terrible assumption when dealing with bulk equipment, however splitting can be

undesirable when dealing with large pieces of military equipment. Many military units have specialized pieces of equipment which come in many different shapes, sizes and weights. The ITDM does not account for these individual requirements and assumes all tonnage is bulk tons. Much of the tonnage in a TPFDD isn't bulk and therefore cannot be split into random amounts.

**PSTDM Introduction**

The model introduced in this thesis is taken heavily from the ITDM. After inspection of the assumptions and solutions, the ITDM may produce incorrect results which could be solved with modifications. This research improves the ITDM by identifying requirements that cannot be split and ensuring they travel as a whole unit on a proper vehicle.

**Assumptions of PSTDM**

The assumptions of the PSTDM follow closely with the ITDM assumptions discussed earlier with a few distinct differences. One such difference is the fact that all tonnage is not considered bulk. Figure 4 shows a sample requirement from a notional TPFDD. The solution provided by the ITDM is given by Figure 6.

Service	ReqID	UTC	PAX	Total STons	Bulk STons	Oversize STons	Outsize STons	NAT STons	Description
ARMY	2:AA00	1322	76	236.8	14.6	178.6	43.6	0	HHC INF DIV BDE LID 13006

**Figure 4. Example of TPFDD Oversize Problem**

RLN	CCC	Mtons	Stons	Sqft	NumPieces	Length	Width	Height	Description
AA00	R2D	39	16.1	183	2	275	96	102	Z40439TRUCK

**Figure 5. Level 4 Example of Oversize**

Number of Vehicles	Type	POE	POD	Day leaving	Tons Moved	Requirement number
10	M35	KUHE	KUHA	Day 1	80	1
1	HEMTT	KUHE	KUHA	Day 2	6.8	1
1	M35	KUHE	KUHA	Day 2	8	1
2	HEMTT	KUHE	KUHA	Day 3	14	1
8	M35	KUHE	KUHA	Day 3	64	1
8	M35	KUHE	KUHA	Day 17	64	1

**Figure 6. Example of Oversize Solution**

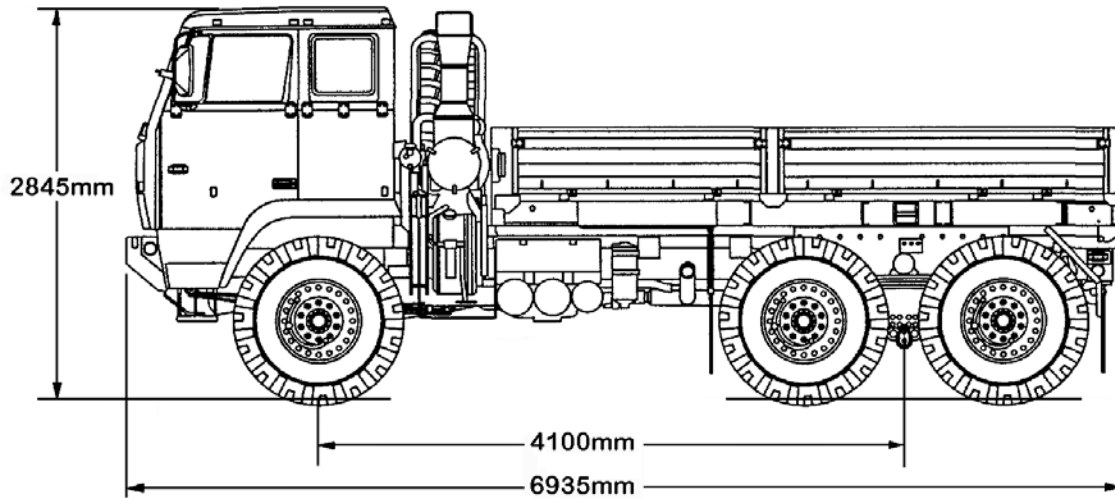

**Figure 7. Picture of Z40439**



All vehicles given by the solution in Figure 6 are military trucks. Any one of the trucks provided in the solution does not have a planned max capacity higher than 8 tons for a vehicle. When examining the Level 4 Data it becomes evident that, at a minimum, one of the pieces of equipment will not fit on the truck. Figure 5 shows the data given from the Level 4 Data. This particular requirement is two trucks each weighing 16.1 tons and is considered oversized. Figure 7 shows a picture of the type of truck in the requirement in question. The ITDM solution splits the tonnage amongst 3 trucks. This requirement in itself requires an entire truck, which is not represented by the ITDM solution. The solution provided by the ITDM will be feasible, but rationally the solution is not feasible. Therefore, not all requirements can be split in order to fill a vehicle to capacity.

Requirements will be treated as bulk tons and oversized/outsized tons. Bulk tonnage will be the only loads that the new model will be allowed to split. Therefore, if the example above was bulk requirements this would be a valid movement and split. Vehicles allocated in the solution will be assumed to travel only between their given POD and Destination and deviations are not authorized anywhere on their trip. Multiple pickups at different PODs or multiple deliveries at different final destinations are also not accounted for and not represented in the model. Outsize and oversize loads will be combined so that there are a single tonnage of oversized requirements and bulk requirements. All bulk short tons can be transported by any vehicle. Another assumption the ITDM makes is that a host nation's transportation system from POD to Destination can accommodate oversized requirements. The PSTDM assumes that oversize and outsize requirement will move by military air or rail only.

## PSTDM Overview

To properly identify oversize and outsized requirements, individual pieces of equipment have to be identified. In order to properly identify the equipment the PSTDM needs more information than what the training TPFDD provides. The information needed is found in the TPFDD's Level 4 data. The level 4 data of a TPFDD is the description (length, width, height and weight) of each piece of equipment that is used to create a TPFDD Requirement  $n$ . Figure 4 is an example of a small sample of a single requirement of a TPFDD. A Requirement  $n$  is then nothing but the sum of all types of tonnage to include Bulk, oversized and outsized short tons. In Figure 4, the three key pieces to the total short tons of the TPFDD are shown. Thus, each requirement on a TPFDD can break into its individual pieces and parts, and then be used in the model. Therefore, the model will make each piece of a TPFDD into a separate Requirement that can be identified as either oversize/ousize or bulk.

RLN	CCC	Mtons	Stons	Sqft	NumPieces	Length	Width	Height	Description
JR33 B1	R2D	19.2	2.9	125	2	187	96	74	T61494TRK UTIL
JR33 B1	R2C	13.1	1.4	76	1	147	74	83	W95537TRAILER
JR33 B1	R2D	19.5	1.9	96	1	166	83	98	W95811TRAILER

**Figure 8. Example of Level 4 Data**

To keep a requirement from being split, an indicator variable is created  $L_{nijmkv}$ . The indicator variable is a binary variable and ensures each flow variable not associated to a bulk requirement is not split across different vehicles. It accomplishes this by not allowing the flow variable to be less than or equal to the indicator variable times the total weight of a single requirement.

Oversized cargo was not identified or dealt with in the RTDM or ITDM. In order to properly represent the oversized and outsized requirements, the model takes the definition of outsize and oversize and identifies, within the level 4 data, each of the requirements that meet the criteria. The model then takes what is identified as oversized and outsized and adds them to only vehicles identified as able to carry oversized or outsized loads. Therefore, the example in Figure 7 would be loaded on a C-5 or C-17 for air transportation and a train if going by ground. To represent this in the PSTDM model, a new binary function was created.  $H(m, k)$  (30) is a binary function that takes the mode and type of vehicle then indicates if a vehicle can carry an oversized or outsized requirement.

$$H(m, k) = \begin{cases} 1, & \text{if Mode } m \text{ of vehicle Type } k \text{ can carry oversized/outsized cargo} \\ 0, & \text{otherwise} \end{cases} \quad (30)$$

Another additional set that was created is the Valid Flow Oversized (VFO). VFO

$$\{(n, i, j, k, m, v) \mid (A(n, v) \cdot C(m, k) \cdot H(m, k) \cdot D(n, i, j) + B(n, v) \cdot H(m, k) \cdot C(m, k) \cdot D(n, i, j)) = 1\}$$

can be broken into two parts, on time and late. Both parts of the set are very similar to the VF set but with one difference, the new binary function  $H(m, k)$ . The new binary function is added to both parts of the set VFO to ensure that vehicles that carry VFO cargo are designated as able to do so.

In order to represent the SOS constraints mathematically, a true understanding of what the variables are doing is crucial. The items in the set VFO are utilized to create the

SOS in a slightly different way. The constraint would mathematically look like (37)

$$\sum_{\{(ijmkv)|(nijmkv)\} \in VFO} L_{nijmkv} = 1 \quad \forall (n, i, j, m, k, v) \in VFO$$

What this means is that for each Requirement  $n$  an integer variable is created that will be of POD  $i$  and Destination  $j$  for Mode  $m$  and for each Type  $k$  and for each Day  $v$ . Thus, the SOS constraint will only allow one of the indicator variables within the SOS to be nonzero while the rest of the variables must equal zero. This will help improve the processing time since adding another integer variable with the indicator variable will increase processing time.

All short tons in the ITDM were thought to be bulk tons in the assumptions, but this will cause problems with estimates in vehicles, as all vehicles may not be sufficiently capable of carrying all the same loads. Two basic sets  $O$  and  $B$  are created in order to separate oversized and outsized cargo and bulk cargo. Since these two new sets are created it means the set  $N = O \cup B$ . These two sets will be used in the model in order to allow only bulk cargo to be split across multiple vehicles.

**Table 12. PSTDM Basic Set**

<b>Set</b>	<b>Description</b>
$I$	Set of all PODs $i$
$J$	Set of al Destinations $j$
$K$	Set of all vehicle Types $k$
$M$	Set of all vehicles Modes $m$
$N$	Set of all Movement Requirements $n$ , $O \cup B$
$V$	Set of all possible delivery Days $v$
$M_{ij}$	Set of all Modes $m$ with valid direct paths between POD $i$ and Destination $j$
$K_m$	Set of all vehicles of Type $k$ which are of Mode $m$
$N_{ijv}$	Set of Requirements $n$ that are eligible to deliver from POD $I$ to Destination $j$ on Day $v$
$O$	Set of all Requirements $n$ that are oversized and outsized
$B$	Set of all Requirement $n$ that are bulk

**Table 13. PSTDM Function Derived Sets**

<b>Set</b>	<b>Description</b>	<b>Mathematical Notation</b>
VV	Valid Vehicle	$\{(i, j, k, m, v   G(n, v) \cdot C(m, k) = 1\}$
VF	Valid Flows	$\{(n, i, j, k, m, v)   A(n, v) \cdot C(m, k) \cdot D(n, i, j) + B(n, v) \cdot C(m, k) \cdot D(n, i, j) = 1\}$
LF	Late Flows	$\{(n, i, j, k, m, v   B(n, v) \cdot C(m, k) \cdot D(n, i, j) = 1\}$
VR	Valid Routes	$\{(n, i, j   D(n, i, j) = 1\}$
VO	Valid Outloading	$\{(i, m, v   E(i, m, v) = 1\}$
VU	Valid Unloading	$\{(j, m, v   F(j, m, v) = 1\}$
VFO	Valid Flow Oversized	$\{(n, i, j, k, m, v)   (A(n, v) \cdot C(m, k) \cdot H(m, k) \cdot D(n, i, j) + B(n, v) \cdot H(m, k) \cdot C(m, k) \cdot D(n, i, j)) = 1\}$

**Table 14. PSTDM Parameters**

<b>Parameter</b>	<b>Description</b>
$b_k$	Daily operating cost for Type $k$ vehicle
$p_k$	Average payload of Type $k$ vehicle
$r_{nij}$	Total weight (in short tons) of Requirement $n$ that must be delivered from POD $i$ to Destination $j$
$ad_n$	Day when Requirement $n$ arrives at its given POD
$rd_n$	The Required Delivery Date (RDD) at the given Destination for Requirement $n$
$qd_n$	Maximum allowable extension days beyond RDD in which the Requirement $n$ can be delivered late to a given destination (with penalty)
$g$	Late penalty per short ton per day
$o_{imv}$	Maximum number of Mode $m$ vehicle that can be outloaded at POD $i$ on Day $v$
$u_{jmv}$	Maximum number of Mode $m$ vehicles that can unloaded at Destination $j$ on Day $v$
$w_{ijmk}$	Number of possible cycles in a day between POD $i$ and Destination $j$ via Mode $m$ , Type $k$ vehicle

**Table 15. ITDM Decision Variables**

<b>Variable</b>	<b>Description</b>
$x_{ijmkv}$	Number of vehicles of Mode $m$ , Type $k$ that are required on Day $v$ to deliver Requirement $n$ from POD $i$ to Destination $j$
$y_{nijmkv}$	Short tons of Requirement $n$ delivered from POD $i$ to Destination $j$ on Mode $m$ , Type $k$ vehicle on Day $v$
$L_{nijmkv}$	Indicator variable of Requirement $n$ from POD $i$ to Destination $j$ of Mode $m$ , Type $k$ on Day $v$

### Model 3. PSTDM

$$\text{Minimize } \sum_{(i,j,m,k,v) \in VV} b_k x_{ijmkv} + \sum_{(n,i,j,m,k,v) \in LF} g(v - rd_n) y_{nijmkv} \quad (31)$$

Subject to

$$Y_{nijmkv} \geq L_{nijmkv} r_{nij} \quad \forall (n, i, j, m, k, v) \in VFO \quad (32)$$

$$\sum_{M_{ij}} \sum_{K_m} \sum_{v=ad_n+1}^{rd_n+q_n} y_{nijmkv} = r_{nij} \quad \forall (n, i, j) \in VR \quad (33)$$

$$\sum_J \sum_{K_m} w_{ijmk} x_{ijmkv} \leq o_{imv} \quad \forall (i, m, v) \in VO \quad (34)$$

$$\sum_I \sum_{K_m} w_{ijmk} x_{ijmkv} \leq u_{jmv} \quad \forall (i, m, v) \in VU \quad (35)$$

$$\sum_{N_{ijv}} y_{nijkmv} \leq x_{ijmkv} w_{ijmk} p_k \quad \forall (i, j, m, k, v) \in VV \quad (36)$$

$$\sum_{\{(ijmkv)|(nijmkv)\} \in VFO} L_{nijmkv} = 1 \quad \forall (n) \in O \quad (37)$$

$$x_{ijmkv} \in \{0\} \cup \mathbb{Z}^+ \quad \forall (i, j, m, k, v) \in VV \quad (38)$$

$$y_{nijmkv} \geq 0 \quad \forall (n, i, j, m, k, v) \in VF \quad (39)$$

$$L_{nijmkv} \in \{0, 1\} \quad \forall (n) \in O \quad (40)$$

### PSTDM Summary

The PSTDM adds a new binary function (30) and basic sets  $O$  and  $B$  to help identify outside or oversized requirements. The key though is the new indicator variable  $L_{nijmkv}$  which will not allow the Requirement  $n$  to be split amongst vehicles in the



solution. The additions of the new basic sets, binary functions and variables will allow the PSTDM to only split bulk cargo and keep oversized and outsized cargo to remain intact. The model will also only allow oversized cargo on vehicles that have been designated as oversized capable vehicles.

## **IV. Analysis and Results**

### **Chapter Overview**

I compared three test cases between the ITDM vs. PSTDM and show the similarity and differences of the models. I point out the differences on how the models handle requirements being split and the movement of oversized and outsized requirements.

The ITDM and PSTDM are implemented using a combination of Microsoft Office Excel 2007 and the Optimization software LINGO 11 (Lindo Systems 2008). The models use a Decision Support System (DSS) in Excel which implements a graphic user interface (GUI) in order to allow users to input the necessary parameters and data. After all of the data and parameters have been entered, Visual Basic for Applications (VBA) code is energized to begin creating the necessary code and constraints in order to solve the mixed integer problem. Once VBA preprocesses the data in Excel, it then passes it to LINGO to determine the best solution. Once LINGO finds a solution, VBA then takes the LINGO solution and rewrites that solution back into excel as a user friendly readable solution. Settings used for LINGO will be addressed in the Appendix of this document.

### **Model Testing.**

In conducting the test, three TPFDD's and three sets of level 4 data were used. Both the bulk and oversize/outsize sets of data were drawn from a Notional TPFDD in Analysis of Mobility Platform 14.2.1 (AMP14.2.1). AMP14.2.1 is a simulation tool used by USTRANSCOM to receive insights on how to move people and equipment from a

unit's home station to their deployment location. The only model that will use the level 4 data in these test cases is the PSTDM. The three test cases are in increasing order with the number of requirements. The user inputs used for test case remain constant so that each model has the same data. Extension days for each requirement is equal to 10, or  $qd_n = 10$ . For each POD  $i$  and Destination  $j$  the number of vehicles that can be processed is 5,  $o_{imv}, u_{imv} = 5$ . Outload and unload values are chosen such that they are large enough not to become a bottleneck in the system. The cycle for each POD/Destination pair is set to one cycle for each vehicle. In order to produce solutions in a reasonable time, a relative optimality tolerance setting was used within LINGO. One of the benefits of the ITDM and PSTDM, over previous methods, is the speed. Thus, to keep the models processing time sensible for analysts, the solver was set to search for a true optimal solution only for the first five minutes. If the optimal solution was not found within the first five minutes, then a feasible solution found within .2, or 20%, of the linear program relaxation low bound was sufficient as the solution. Both models will get exactly the same requirements and data. The PSTDM will have to receive the data from both Level 4 data and TPFDD in order to run properly. But when both models are processing a TPFDD they are exactly the same.

Vehicle Capacity Utilization is also calculated in for each test case run. This calculation is taken from LT Hafich, who used the number to compare the TDM and ITDM in the original research. Approximate Capacity Utilization (ACU) will be used to compare model solutions. ACU is defined as the total short tonnage included in the

TPFDD divided by the approximate amount of cargo-space obtained by the model's vehicle allocations. (Hafich, 2013) To get the value, each vehicle variable is multiplied by its respective payload and cycle, and summed for all nonzero vehicles.  $S$  represents the sum of all requirements and is the total tonnage listed in the TPFDD. Mathematically ACU is defined as

$$\frac{S}{\sum_X x_{ijmk} P_k W_{ijmk}} \quad (41)$$

where  $X$  is all the nonzero vehicle variables for the ITDM and PSTDM. The point of the ACU is to determine how well the model is utilizing the vehicle chosen. We use this number to compare and contrast models in determining how each model uses the vehicles. ACU near 100% means those vehicles are being used very close to their average load capacity. Conversely, a number close to zero would mean the opposite.

### **Test Case 1**

Test Case 1 will have approximately 200 requirements for the models. The same TPFDD is used for both models, with level 4 data being introduced into the PSTDM. The first tests initially used all three modes, but because of their small size all requirements were put on trains due to their low cost. Those results are seen in Figure 9. Since rail will cause skewing of the solutions and make the solution very simple, removing rail from the model and solving each problem using only air and road assets provides more interesting and insightful results. Standard user inputs used for this test were  $qd_n = 10$ ,  $w_{ijmk} = 1$ , and both  $o_{imv}, u_{jmv} = 5$ . The late penalty for the each short ton late will be,  $g = 10000$ . Lastly,

since this is the simplest case there is only one POD/Destination combination pair for this TPFDD. Daily cost and average payload for the vehicles used in test case one are shown in Figure 10. A small sample of the 200 lines of the TPFDD for case 1 is presented in Figure 11.

Model	Total Vehicles used	Air Vehicles	Road Vehicles	Rail Vehicles	Late Tons	Total Tons Moved	ACU
ITDM	8	0	0	8	0	1549.8	0.9686
PSITDM	8	0	0	8	0	1549.8	0.9686

**Figure 9. PSTDM Small Solution w/Rail**

Type	Average Payload	Daily Cost
C130	12	10000
C17	35	11000
C5	60	80000
HEMTT	7	101
M1083	5	100
M35	8	102

**Figure 10. Test Case 1 Avg. Payload & Daily Cost**

POD	Destination	Total Ston	Bulk Ston	Oversize Ston	Outsize Ston	EAD	RDD
KUHE	KUHA	4.4	0	4.4	0	45	55
KUHE	KUHA	4.4	0	4.4	0	45	55
KUHE	KUHA	4.4	0	4.4	0	45	55
KUHE	KUHA	4.4	0	4.4	0	45	55
KUHE	KUHA	4.4	0	4.4	0	45	55
KUHE	KUHA	70.7	0	70.7	0	34	62
KUHE	KUHA	70.7	0	70.7	0	34	62
KUHE	KUHA	70.7	0	70.7	0	34	62
KUHE	KUHA	70.7	0	70.7	0	34	62
KUHE	KUHA	70.7	0	70.7	0	34	62
KUHE	KUHA	70.7	0	70.7	0	34	62
KUHE	KUHA	70.7	0	70.7	0	34	62

**Figure 11. TPFDD for Test Case 1**

Inspecting and comparing the ACU results of Test Case 1 in Figure 13, the numbers are very close. The big difference between the two is that the PSTDM utilized almost all air vehicles for both bulk cargo and oversize/outsize cargo. The lone truck carried bulk requirements that could not be distributed in the excess capacity of the aircraft used. In Figure 14, the highlighted movements show that the model splits the bulk cargo amongst the aircraft allocated for oversized requirements, then allocated the cheapest requirements for bulk only movements. The ITDM only allocates about 34% of its vehicles to aircraft and the rest to ground vehicles. Since a majority of the requirements are oversize/outsize cargo in this particular case, this justifies the need for a large proportion of aircraft used by the PSTDM. The PSTDM uses about 50% of the vehicles that the ITDM suggests. This reduction in vehicles does come at a price of 1.42 times the cost as compared to the ITDM. This is an expected increase because of the

requirement that only C-5s and C-17s are able to transport oversized and outsized requirements.

Model	Total Vehicles used	Air Vehicles	Road Vehicles	Rail Vehicles	Late Tons	Total Tons Moved	ACU
ITDM	90	31	59	0	0	1549.8	0.9999
PSITDM	46	45	1	0	0	1549.8	0.9796

**Figure 12. Test Case 1 Results**

Model	OBJ Value	Constraints	Total Variables	Integer Variables	Continous Variables
ITDM	347011	583	26088	228	25860
PSTDM	495000	15279	29968	14924	15044

**Figure 13. Statistics from Test Case 1**

1 HEMTT(s)	leaving POD KUHE for destination KUHA on day 46 (ROAD)	7.00 Short Tons of Movement	202
1 C17(s)	leaving POD KUHE for destination KUHA on day 42 (AIR)	1.40 Short Tons of Movement	9
		17.70 Short Tons of Movement	63
		7.90 Short Tons of Movement	78
		7.90 Short Tons of Movement	91
		0.10 Short Tons of Movement	201
1 C17(s)	leaving POD KUHE for destination KUHA on day 43 (AIR)	1.40 Short Tons of Movement	3
		17.70 Short Tons of Movement	62
		7.90 Short Tons of Movement	89
		7.90 Short Tons of Movement	105
		0.10 Short Tons of Movement	201

**Figure 14. Example of Bulk Distribution**

Lastly, there was improper splitting of in the ITDM solution as shown in Figure 15. The highlighted requirement shows a split in Requirement 26, which was a non bulk requirement in the TPFDD. Since no single item in requirement 26 is less than 1.9 short

tons, splitting one of the requirements would be impossible. In the PSTDM, requirement 26 does not split, shown in Figure 16. The only splitting that the PSTDM allowed was on the bulk cargo.

POD	Destination	Total Ston	Bulk Ston	Oversize Ston	Outsize Ston	EAD	RDD
KUHE	KUHA	1.9	0	1.9	0	34	62

**Figure 15. Requirement 26 in TPFDD**

2 HEMTT(s) leaving POD KUHE for destination KUHA on day 52 (ROAD)		
	2.90 Short Tons of Movement	1
	1.40 Short Tons of Movement	7
	1.40 Short Tons of Movement	14
	1.90 Short Tons of Movement	23
	1.70 Short Tons of Movement	26
	1.60 Short Tons of Movement	35
	1.70 Short Tons of Movement	36
	1.40 Short Tons of Movement	57

5 C17(s) leaving POD KUHE for destination KUHA on day 46 (AIR)		
	1.40 Short Tons of Movement	11
	1.40 Short Tons of Movement	13
	0.30 Short Tons of Movement	15
	1.40 Short Tons of Movement	17
	1.90 Short Tons of Movement	19
	1.90 Short Tons of Movement	21
	1.90 Short Tons of Movement	22
	1.90 Short Tons of Movement	24
	0.20 Short Tons of Movement	26
	1.90 Short Tons of Movement	28
	0.90 Short Tons of Movement	42
	17.70 Short Tons of Movement	59
	3.80 Short Tons of Movement	63
	7.90 Short Tons of Movement	66
	2.50 Short Tons of Movement	68

**Figure 16. Case 1 Solution for ITDM**



5 C17(s)	leaving POD KUHE for destination KUHA on day 35 (AIR)	
		1.40 Short Tons of Movement 2
		1.40 Short Tons of Movement 11
		1.40 Short Tons of Movement 14
		1.40 Short Tons of Movement 15
		1.40 Short Tons of Movement 17
		1.40 Short Tons of Movement 18
		1.90 Short Tons of Movement 23
		1.90 Short Tons of Movement 26
		1.90 Short Tons of Movement 27
		8.40 Short Tons of Movement 35
		8.40 Short Tons of Movement 38
		17.70 Short Tons of Movement 58
		7.90 Short Tons of Movement 66
		7.90 Short Tons of Movement 79
		7.90 Short Tons of Movement 83
		7.90 Short Tons of Movement 97
		7.90 Short Tons of Movement 98

**Figure 17. Case 1 Solution for PSTDM**

### Test Case 2

In the second case, the TPFDD increased from 200 requirements to over 500 requirements with a total tonnage moved to 2810.1 short tons. In the second case, the user inputs used were  $qd_n = 10$ ,  $w_{ijmk} = 1$ , and both  $o_{imv}, u_{jmv} = 5$ . The late penalty was again  $g = 10000$  for the each short ton late. There are also three pairs of POD/Destination combinations for this TPFDD. The average payload and cost from Figure 11 were used in Case 2 as well. As in Test Case 1, when adding trains to the available vehicles, the ITDM and PSTDM put all requirements onto trains. For comparison reasons in Test Case 2, Mode Rail was removed from the model.

Model	Total Vehicles used	Air Vehicles	Road Vehicles	Rail Vehicles	Late Tons	Total Tons Moved	ACU
ITDM	207	43	164	0	0	2810.1	0.9997
PSTDM	96	76	20	0	0	2810.1	0.9976

**Figure 18. Test Case 2 Results**

Comparing the Test Case 2 results in Figure 18, the ITDM increased its use of air vehicles. Now air vehicles attribute to almost 21% of the total vehicles used. This happened because of the increase in short tons but no increase of cycles, outload or unloading. Keeping outload and unload constraints constant the model must figure how to flow large amounts of cargo in and out of POD and destinations. The model used the max ground vehicles it could outload and unload on a single day. Air vehicles are the only other choice for the model to use when reaching those limits, hence the increase of air vehicles. The PSTDM increased its use of road vehicles. The increase in road vehicles is a direct correlation to the increase of bulk cargo requirements in test case 2. Figure 19 depicts the bulk requirements for test case 2, which is much higher than in test case 1 where bulk short tons were equal to 26.6.

The ACU between the two models is also very similar and vary only by .002% . The difference is smaller in test case 2 than in test case 1. This decrease in ACU seems counterintuitive since usually more requirements lower the ACU due to the difficulty to combine all the individual requirements in a manner that fit exact capacity requirements for the vehicle. The high ACU is attributed to the larger bulk requirements in test case 2. The higher bulk cargo requirements allow the PSTDM to partition the bulk cargo onto

vehicles already being used for oversized requirements, in turn utilizing the larger air vehicles to capacity.

POD	Destination	Total Ston	Bulk Ston	Oversize Ston	Outsize Ston	EAD	RDD
KUHE	KUHA	1.9	16.6	0	0	34	62
KUHE	KUHA	1.9	71.6	0	0	42	50
KUHE	KUHA	1.9	60.7	0	0	34	62
KUHE	KUHA	1.9	31.1	0	0	34	62
KUHE	KUHA	1.9	11.6	0	0	52	61
KUHE	KUHA	1.9	31.1	0	0	34	62
OBGW	ORBM	1.9	1.4	0	0	55	70

**Figure 19. Test Case 2 Results**

Model	OBJ Value	Constraints	Total Variables	Integer Variables	Continuous Variables
ITDM	489932	1400	94746	528	94218
PSTDM	838037	32278	63768	31506	32262

**Figure 20. Test Case 2 Statistics**

Total variables of the PSTDM are significantly smaller than the ITDM. Test Case 1 contained a small difference in total variables but test case 2 has over 30,000 more variables. The ITDMs increase of variables is in the continuous category and the increase of variables in the PSTDM are integers. Normally, an increase of integer variables is not ideal, as integers can make the model harder to solve. The increase in integers is due to adding another integer for every  $y_{nijmkv}$  created in  $n \in O$ . The equation (37)

$$\sum_{\{(ijmkv)(nijmkv)\} \in VFO} L_{nijmkv} = 1 \quad \forall (n) \in O \quad \text{helps reduce the amount of integers being}$$

solved by the optimization software. SOS1 are used by the solver to determine which  $L_{nijmkv}$  variable will be set to one. Once the solver determines which  $L_{nijmkv}$  is set to one, then the rest of the integer variables are all set to zero and not evaluated. This eliminates many of the integers created by the PSTDM, but all integers are reported in the statistics provided in all test cases. This is a trend seen in the PSTDM; constraints will be very close to the total continuous variables; all integers created are not evaluated and therefore the total integers created can be misleading.

### Test Case 3

This test case is used to try and determine how the model reacts to large amounts of data. For this model user inputs used were kept at  $qd_n = 10$ ,  $w_{ijmk} = 1$ , and both  $o_{imv}, u_{jmv} = 10$  along with the late penalty  $g = 10000$  for each short ton late. The reason for an upload and unload constraint increase is that both models were infeasible at  $o_{imv}, u_{jmv} = 5$ . The POD/Destination combinations are also increased to six pairs. The average payload and cost from Figure 10 are used in Case 3. Rail is also left out again due to the ITDM using Rail for all movements. The TPFDD and Level 4 Data are not shown because of their size, which has increase to over 2500 requirements.

Model	Total Vehicles used	Air Vehicles	Road Vehicles	Rail Vehicles	Late Tons	Total Tons Moved	ACU
ITDM	1685	0	1685	0	0	13449.5	0.9977
PSTDM	419	382	37	0	0	13449.5	0.9152

**Figure 21. Test Case 3 Results**

Examining Figure 21, one can see the disparity in the amount of vehicles used in test case three. All three cases show a disproportion in the amount of vehicles used in each solution, but as the TPFDDs get larger, the imbalance is exacerbated. In Test Case 3 the ITDM suggested 1685 vehicles with 100% of them trucks, which is the cheapest transportation vehicle provided in the Test Case. The PSTDM provides a solution with 419 vehicles, which is 25% of the total vehicles suggested by the ITDM solution. The PSTDM only utilized 37 Road vehicles, which is fewer than 9% of the total vehicles. Comparing the ITDMs 100% ground vehicles to the PSTDM of 9% it becomes evident that an analyst determining feasibility will have very different solutions.

There is also an issue with the lowest cost of the ITDM in Figure 22. The objective cost between the ITDM and PSTDM are very different. Looking at the difference of the two objective functions, the PSTDM is over 200 times the cost of the ITDM. This is a very large difference when we think of what the objective function is calculating. Recall the objective functions of the ITDM and PSTDM are identical and are in equation 31. Both functions are minimizing the cost of the movement by multiplying each vehicle by the estimated cost to utilize that vehicle. So the difference of over 24 times on a TPFDD with 2500 requirements is a concern when TPFDDs can have

10,000 or more requirements. Thus, giving analysts more realistic numbers on cost and vehicles needed to move equipment will lead to a more informed analysis. As the point of the model is to give force flow analysts a tool to test feasibility of the OPPLANs TPFDD, the PSTDM can provide a more realistic and adequate solution of the type and quantity of vehicles used.

Model	OBJ Value	Constraints	Total Variables	Integer Variables	Continuous Variables
ITDM	171870	4657	514230	1404	512826
PSTDM	4226072	183485	364154	180508	183646

**Figure 22. Test Case 3 Statistics**

### **Validation and Verification**

Validation and Verification are conducted on models for two reasons. Validation makes sure the model appropriately represents the problem at hand. Verification determines if the model is doing things right, or is the model correct per the specifications claimed.

#### **Validation**

Test Case 2 provides the validation of the PSTDM. Figure 15 – 17 show the improper splitting of requirements in the solutions on Test Case 2. The solutions of the ITDM and PSTDM provide the necessary evidence that the ITDM requirements are split to maximize utilization and reduce cost. The PSTDM solutions in Figure 17 don't allow that to happen in the model. Splitting lowers the cost of the ITDM and it also puts equipment on vehicles that may be incorrect for the size of a particular requirement.

Test Case 2 presents a better solution than what the ITDM offered. The solution offered by the ITDM doesn't account for the oversized or outsized equipment or the splitting of requirements. When taking into account these factors, the solutions are very different; specifically in regards to vehicles selected and cost. To validate how well this model represents a true allocation on actual TPFDD's is difficult since the movements won't occur until after an operation is started.

### **Verification**

Incorporating the indicator variable and SOS1 constraints, the model restricts the model from splitting loads in an improper way and loads oversized requirements on proper vehicles. Shown in the test cases, the model separates the requirements into two different sets. The bulk set is allowed to be transported and split among all vehicles available as in Figure 14. The oversized set is not split and must be on either a C-5 or C-17 like in Figure 17. The solutions then represent a combination of vehicles able to carry properly identified requirements.

### **Summary**

The PSTDM prevented all requirements that were not identified as bulk from being split amongst different vehicles in the solution. This alone will provide a better estimation of the true requirements of a TPFDD. Restricting what vehicles can load oversized/outsized requirements also gives the model a more reasonable approach to a solution. As shown in the three test cases, there is a large difference between the ITDM and PSTDM solutions with regards to vehicle solution and objective function cost.





## V. Conclusions and Recommendations

### Chapter Overview

The ITDM is a sufficient tool, but as pointed out in this thesis, the model recommends a mix of vehicles that cannot always support the requirements of the TPFDD. Force flow analysts must look at large vehicle mixtures and make a quick determination of feasibility and then conduct sensitivity analysis, based on the model's solutions. If an analyst uses the current ITDM solutions it could possibly cause a fault in the feasibility of the answers and a TPFDD may be considered feasible when truly not.

The PSTDM solved the issues identified in the ITDM. The PSTDM does not allow requirements to be split across vehicles unless the requirement is identified as bulk. In addition to restricting requirements to not be split across vehicles, requirements were also identified as oversized or outsized. The PSTDM will only allow those requirements to be loaded on vehicles identified as oversized and outsized capable. These added constraints drastically changed the solution space in which analysts now must navigate.

The PSTDM can provide force flow analysis with more realistic insight of what type of vehicle mixture will work with the given TPFDD. Since the ITDM did not take into account the size of requirements, the costs were substantially lower, the vehicle mixture was skewed with a very high ground vehicle and small air vehicle mixtures, all compared to the PSTDM. Although, the PSTDM does create more requirements by separating each single TPFDD requirement into multiple requirements for level 4 data.

These added requirements provide the model a level of fidelity necessary to provide analysts the proper solution that will be closer to what type of assets will be needed to move said equipment.

Not only does the model give insight on vehicle mixtures, but provides the analyst prudence to the actual cost of the movement. In the ITDM, the cost of the TPFDD was extremely low due to the utilization of many low cost ground vehicles. In the PSTDM, air vehicles are the primary utilized vehicles in order to transport oversized and outsized equipment, while cheaper ground transportation is used to move bulk equipment. The test cases in Chapter 4 showed that the cost was 24 times more than the ITDM due to these differences. This is significant to force flow analysts when millions of government dollars are spent annually moving military equipment.

The more realistic solutions provided by the PSTDM will allow force flow analysts to conduct initial feasibility and sensitivity analysis on solutions that are more representative of the current environment. The PSTDM also allows the analyst to predict vehicle mixtures for different OPLANs better. A 250 ton Army Postal unit needs a completely different set of vehicles for theater transportation than a 250 ton Army Aviation unit. The ITDM would have provided the same vehicle mixture for both units.

### **Recommendations for Future Research**

A heuristic would provide solutions faster for larger TPFDDs. In Chapter 4 Test Case 3, the total integer variables generated is over 180,000 thousand on 2500 requirements. TPFDD's are normally thousands of requirements which make the PSTDM

even larger. With such large problems, a heuristic would work better in providing good solutions for the problem trying to be solved by the USTRANSCOM Planners. Since the point of the model is to try and determine if a TPFDD is feasible, then the PSTDM works well but having it run faster would be beneficial for sensitivity analysis or just for having the ability to run multiple large scale models quickly.

Another improvement on the PSTDM would be to take into account volume and weight when determining the limits of a vehicle. The Level 4 data provides the length, width and height of each piece of equipment. This will allow for more accurate solutions when determining the amount of vehicles needed to move outsized and oversized equipment. Volume would also affect the approximate capacity utilization number significantly. In reality, an aircraft may be filled to capacity faster on volume than on weight and this should be reflected by the model. This requirement may also increase the amount of assets needed for transportation due to a vehicle reaching the volume capacities faster.

Prioritizing cargo would also benefit analyst modeling feasibility of TPFDDs. Different cargo will have different priorities which will determine if the requirement is transported on military transportation assets or on a contracted vehicle. Hazardous cargo for example will be transported with similar type hazardous cargo and will not be mixed with other types of hazardous cargo. Equipment also deemed sensitive, like many MRAPs, are required to be moved by military personal and military transportation assets. Identifying these types of hazardous cargo will impact ACU, type, and number of vehicles needed to move a set of requirements.

Split delivery has been proven to be a more efficient way of delivering equipment to multiple destinations. The assumption of the PSTDM is that a vehicle will only pick up from a single POD and deliver to a single destination. There is a lot of research on split deliveries that optimize routes and utilization of vehicles. During this research nothing was identified about how to determine a set of multimodal vehicles to move a set of requirements. Logically, it makes sense that a large aircraft like a C-5 or train would carry equipment to more than one location but the model doesn't currently address that situation. Allowing the model to conduct correct split operations could make the vehicles more efficient.

Lastly, identifying types of equipment that could move themselves to the final destination would help lower the number of vehicles and cost of movements. The TPFDD has a Unit Line Number (ULN) which is a unique identifier for each piece of military equipment. Determining the distances that vehicles like trucks, helicopters and other rolling stock will move themselves can help reduce the number of vehicles and cost to move requirements.

## Appendix A. LINGO 11 Settings

Lingo defaults were used except as noted below.

1. Integer Solver settings
  - a. Optimality tab
    - i. Relative = .2
    - ii. Time to Relative (sec) = 300
2. General Solver
  - a. Runtime Limits
    - i. Time (sec) = 1200
3. Model Generator
  - a. Generator Memory Limit (MB) = 500MB

## **Appendix B. TPFDD and Full Solutions for Test Cases**

The full data sheet and solutions for all test cases are too large to integrate into the thesis. Therefore, any reader that is interested in the data sets is recommended in contacting Dr. Jeff Weir, of the Air Force Institute of Technology's Department of Operational Sciences (AFIT/ENS). Dr. Weir can be reached at [jeffery.weir.2@us.af.mil](mailto:jeffery.weir.2@us.af.mil) or at (937) 255-6565 x4523

## **Appendix C. PSTDM Code**

The VBA code used in creating the ITDM and PSTDM is available upon request. The code can be requested through Dr. Jeff Weir, of the Air Force Institute of Technology's Department of Operational Sciences (AFIT/ENS). Dr. Weir can be reached at [jeffery.weir.2@us.af.mil](mailto:jeffery.weir.2@us.af.mil) or at (937) 255-6565 x4523

## Bibliography

- Baker, S. F., Morton, D. P., Rosenthal, R. E., & Williams, L. M. (1999). *Optimizing Strategic Airlift*. Monterey: DTIC.
- Beale, E., & Tomlin, J. (1970). *Special facilities in a general mathematical programming system for non-convex problems using ordered sets of variables*. London: Tavistock Publications Limited.
- Bisschop, J. (2009). *AIMMS Optimization Modeling*. Haarlem: Paragon Decision Technology B.V.
- Dror, M., & Trudeau, P. (1989). Savings by Split Delivery Routing. *Transportation Science* , 141-145.
- Giffin, P. F. (1995). The Split Delivery Vehicle Scheduling Problem with Time Windows and Grid Network Distance. *Computer Operations Research* , 655-667.
- Hafich, M. (2013). *A Mixed Integer Programming Model for Improving Theater Distribution Force Flow Analysis*. Dayton, OH: DTIC.
- Longhorn, D. C., & Kovich, J. M. (2012). *Solving the Theater Distribution Problem Using Planning Factor and Integer Programming Approaches*. Scott Air Force Base: USTRANSCOM.
- Mckinzie, K., & Barnes, J. (2004). A Review of Strategic Mobility Models Supporting the Defense Transportation System. *Mathematical and Computer Modeling* , 839-869.
- Nowak, M. A. (2005). *The Pickup and Delivery Problem with Split Loads*. Atlanta: Georgia Institute of Technology.
- Sebbah, S., Ghanmi, A., & Boukhtouta, A. (2011). *Design of Tactical Support Strategies in military Logistics: Trade-offs Between Efficiency and Effectiveness*. Ontario: Canadian Operational Support Command.
- Staff, J. C. (2008). *Joint Publication 4-0 Joint Logistics*. Washington D.C.: JCS.
- Staff, J. C. (2010). *Joint Publication 4-09 Distribution Operations*. Washington D.C.: JCS.



MAJ Charles Flores Graduated from University of Colorado at Colorado Springs (UCCS) in 2003 with a Bachelor of Science degree in Mathematics. In May of 2003, MAJ Flores was commissioned through the UCCS Reserve Officer Training Corp in the Aviation (AV) Branch and was activated into the Active Duty in June of 2003. After activation, MAJ Flores attend Flight School at Fort Rucker, Al from 2003-2004 where he graduated SERE B AV Officer Basic School and the Flight School 21 UH-60 Blackhawk course. After graduation he was stationed with 2<sup>nd</sup> -501<sup>st</sup> Aviation (AV) Battalion (BN), 4th Brigade (BDE), 1<sup>st</sup> Armored Division in Hanau Germany where he spent 19 months as an Assistant Operations Planner (S-3) and Platoon leader. The Army deactivated the legacy unit of 2nd -501<sup>st</sup> AV BN, 4th BDE 1<sup>st</sup> Armored Division and took this unit and converted it into a new Modular Combat Aviation Brigade (CAB) at Fort Riley, KS. The unit was reflagged as 3-1 Assault Helicopter Battalion, 1<sup>st</sup> CAB. In the CAB, CPT Flores held the positions of Platoon Leader, Assistant S-3, Battle CPT and BN S-4. Upon his completion of a tour to northern IRAQ, CPT Flores attended the Engineer Captains Career Course at Fort Leonard Wood, Mo. While at Fort Leonard Wood, CPT Flores received a Masters Degree in Engineering Management from the University of Missouri Science and Technology. After Graduation, CPT Flores received orders to report to Fort Drum, NY. Joining the 10<sup>th</sup> CAB at Fort Drum, he took command of Headquarter and Headquarter Company (HHC) 2-10 Assault Helicopter Battalion. As a commander he trained and deployed his unit to Forward Operation Base (FOB) Shank, Afghanistan where he took on the duties of the aviation FOB mayor and project manager for the

airfield construction at FOB Shank. While deployed CPT Flores changed command and become the 10<sup>th</sup> CAB Aviation Liaison to the 1<sup>st</sup> Cavalry at Bagram Airfield. Returning back from Afghanistan, CPT Flores assumed the duties as BDE Assistant S-3 until he attended AFIT in the fall of 2012.

REPORT DOCUMENTATION PAGE			Form Approved OMB No. 0704-0188		
<p>The public reporting burden for this collection of information is estimated to average 1 hour per response, including the time for reviewing instructions, searching existing data sources, gathering and maintaining the data needed, and completing and reviewing the collection of information. Send comments regarding this burden estimate or any other aspect of this collection of information, including suggestions for reducing the burden, to the Department of Defense, Executive Service Directorate (0704-0188). Respondents should be aware that notwithstanding any other provision of law, no person shall be subject to any penalty for failing to comply with a collection of information if it does not display a currently valid OMB control number.</p> <p><b>PLEASE DO NOT RETURN YOUR FORM TO THE ABOVE ORGANIZATION.</b></p>					
1. REPORT DATE (DD-MM-YYYY) 27-03-2014		2. REPORT TYPE Master's Thesis		3. DATES COVERED (From - To) Aug 2012-Mar 2014	
4. TITLE AND SUBTITLE  A Proper Splitting Theater Distribution Model for Improving Force Flow Analysis			5a. CONTRACT NUMBER		
			5b. GRANT NUMBER		
			5c. PROGRAM ELEMENT NUMBER		
6. AUTHOR(S)  Charles M. Flores Major, U.S. Army			5d. PROJECT NUMBER JON 13S141		
			5e. TASK NUMBER		
			5f. WORK UNIT NUMBER		
7. PERFORMING ORGANIZATION NAME(S) AND ADDRESS(ES) Air Force Institute of Technology Graduate School of Engineering and Management (AFIT/ENS) 2950 Hobson Way, Building 640 WPAFB OH 45433-8865			8. PERFORMING ORGANIZATION REPORT NUMBER  AFIT-ENS-14-M-07		
9. SPONSORING/MONITORING AGENCY NAME(S) AND ADDRESS(ES) United States Transportation Command Joint Distribution Process Analysis Center Attn: Pat Mcleod 508 Scott Drive Scott Air Force Base, IL 62225-5357 patrick.k.mcleod.cov@mail.mil			10. SPONSOR/MONITOR'S ACRONYM(S) USTRANSCOM/TCAC		
			11. SPONSOR/MONITOR'S REPORT NUMBER(S)		
12. DISTRIBUTION/AVAILABILITY STATEMENT DISTRIBUTION STATEMENT A: APPROVED FOR PUBLIC RELEASE; DISTRIBUTION UNLIMITED.					
13. SUPPLEMENTARY NOTES This material is declared a work of the U.S. Government and is not subject to copyright protection in the United States.					
14. ABSTRACT United States Transportation Command (USTRANSCOM) force flow analysts perform the daunting task of determining feasibility of vehicle mixtures that will support theater distribution. Analysts conduct sensitivity analysis on the vehicle mixture solution to determine proper feasibility. Their current tool, the Improved Theater Distribution Model (ITDM) uses a multimodal, mixed set of vehicles to model the pickup and delivery of a set of requirements within a given time window. Although, the model is a sufficient tool, it may provide incorrect feasible solutions, which in turn may lead to an improper vehicle mixture for a set of given requirements. Improving upon the ITDM, a Properly Splitting Theater Distribution Model (PSTDM) was created. The PSTDM, like the ITDM, is a mixed integer programming model that allocates specific vehicle types to deliver requirements in a way that minimizes cost and late deliveries. The PSTDM improves upon the ITDM solutions by taking into account and identifying oversized/outsized equipment, preventing improper splitting of requirements and matching vehicles capabilities within requirement demands. The new set of solutions provides analysts the necessary insight on vehicle combinations that provide proper feasible pickup and deliver					
15. SUBJECT TERMS Mixed Integer Programming, Pickup and Delivery with Time Windows, Theater Distribution, Math Programming					
16. SECURITY CLASSIFICATION OF:			17. LIMITATION OF ABSTRACT	18. NUMBER OF PAGES	19a. NAME OF RESPONSIBLE PERSON
a. REPORT	b. ABSTRACT	c. THIS PAGE			Dr. Jeffrey Weir (ENS)
U	U	U	UU	90	19b. TELEPHONE NUMBER (include area code) (937) 255-6565, x4523 Jeffrey.Weir@afit.edu

Reset

Standard Form 298 (Rev. 8/98)  
Prescribed by ANSI Std. Z39.18  
Adobe Professional 7.0